

N-CHANNEL MOSFET

Qualified per MIL-PRF-19500/557

DEVICES

2N6796 2N6796U

LEVELS

**JAN
 JANTX
 JANTXV**

ABSOLUTE MAXIMUM RATINGS ($T_C = +25^\circ\text{C}$ unless otherwise noted)

Parameters / Test Conditions	Symbol	Value	Unit
Drain – Source Voltage	V_{DS}	100	Vdc
Gate – Source Voltage	V_{GS}	± 20	Vdc
Continuous Drain Current $T_C = +25^\circ\text{C}$	I_{D1}	8.0	A dc
Continuous Drain Current $T_C = +100^\circ\text{C}$	I_{D2}	5.0	A dc
Max. Power Dissipation	P_{dl}	25 ⁽¹⁾	W
Drain to Source On State Resistance	$R_{ds(on)}$	1.8 ⁽²⁾	Ω
Operating & Storage Temperature	T_{op}, T_{stg}	-55 to +150	$^\circ\text{C}$

Note: (1) Derated Linearly by 0.2 W/ $^\circ\text{C}$ for $T_C > +25^\circ\text{C}$
 (2) $V_{GS} = 10\text{Vdc}$, $I_D = 5.0\text{A}$

ELECTRICAL CHARACTERISTICS ($T_A = +25^\circ\text{C}$, unless otherwise noted)

Parameters / Test Conditions	Symbol	Min.	Max.	Unit
OFF CHARACTERISTICS				
Drain-Source Breakdown Voltage $V_{GS} = 0\text{V}$, $I_D = 1\text{mA dc}$	$V_{(BR)DSS}$	100		Vdc
Gate-Source Voltage (Threshold) $V_{DS} \geq V_{GS}$, $I_D = 0.25\text{mA}$ $V_{DS} \geq V_{GS}$, $I_D = 0.25\text{mA}$, $T_j = +125^\circ\text{C}$ $V_{DS} \geq V_{GS}$, $I_D = 0.25\text{mA}$, $T_j = -55^\circ\text{C}$	$V_{GS(th)1}$ $V_{GS(th)2}$ $V_{GS(th)3}$	2.0 1.0	4.0 5.0	Vdc
Gate Current $V_{GS} = \pm 20\text{V}$, $V_{DS} = 0\text{V}$ $V_{GS} = \pm 20\text{V}$, $V_{DS} = 0\text{V}$, $T_j = +125^\circ\text{C}$	I_{GSS1} I_{GSS2}		± 100 ± 200	nA dc
Drain Current $V_{GS} = 0\text{V}$, $V_{DS} = 80\text{V}$ $V_{GS} = 0\text{V}$, $V_{DS} = 80\text{V}$, $T_j = +125^\circ\text{C}$	I_{DSS1} I_{DSS2}		25 0.25	$\mu\text{A dc}$ mA dc
Static Drain-Source On-State Resistance $V_{GS} = 10\text{V}$, $I_D = 5.0\text{A}$ pulsed $V_{GS} = 10\text{V}$, $I_D = 8.0\text{A}$ pulsed $T_j = +125^\circ\text{C}$ $V_{GS} = 10\text{V}$, $I_D = 5.0\text{A}$ pulsed	$r_{DS(on)1}$ $r_{DS(on)2}$ $r_{DS(on)3}$		0.18 0.195 0.35	Ω Ω Ω
Diode Forward Voltage $V_{GS} = 0\text{V}$, $I_D = 8.0\text{A}$ pulsed	V_{SD}		1.5	Vdc

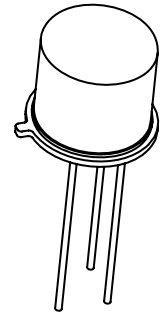

TO-205AF
(formerly TO-39)

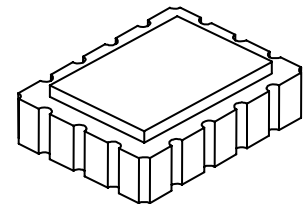

U – 18 LCC

PACKAGE DIMENSIONS

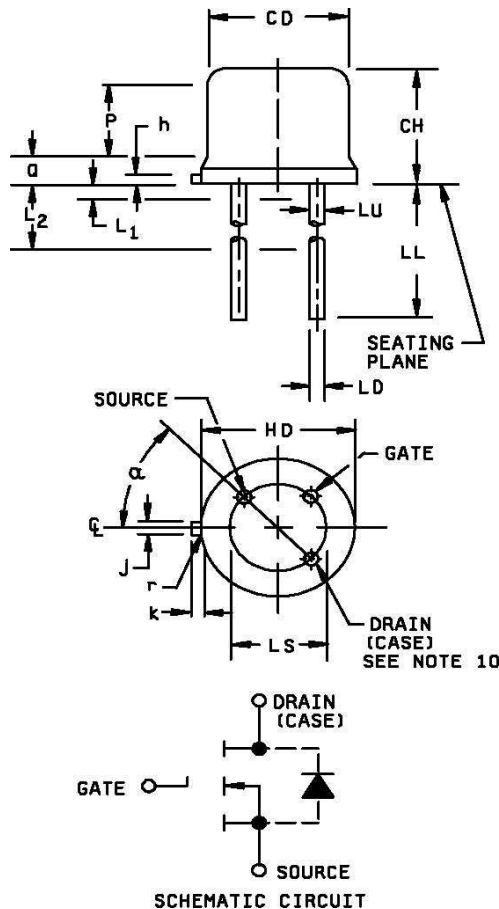

Ltr	Dimensions				Notes
	Inches		Millimeters		
	Min	Max	Min	Max	
CD	.305	.355	7.75	9.02	
CH	.160	.180	4.07	4.57	
HD	.335	.370	8.51	9.39	
h	.009	.041	0.23	1.04	
J	.028	.034	0.72	0.86	2
k	.029	.045	0.74	1.14	3
LD	.016	.021	0.41	0.53	7, 8
LL	.500	.750	12.7	19.05	7, 8
LS	.200 TP		5.08 TP		6
LU	.016	.019	0.41	0.48	7, 8
L1		.050		1.27	7, 8
L2	.250		6.35		7, 8
P	.070		1.78		5
Q		.050		1.27	4
r		.010		0.25	9
α	45° TP		45° TP		6

NOTES:

- Dimensions are in inches. Millimeters are given for general information only.
- Beyond radius (r) maximum, j shall be held for a minimum length of .011 (0.028 mm).
- Dimension k measured from maximum HD.
- Outline in this zone is not controlled.
- Dimension CD shall not vary more than .010 (0.25 mm) in zone P. This zone is controlled for automatic handling.
- Leads at gauge plane .054 +.001, -.000 (1.37 +0.03, -0.00 mm) below seating plane shall be within .007 (0.18 mm) radius of true position (TP) at maximum material condition (MMC) relative to tab at MMC.
- LU applies between L1 and L2. LD applies between L2 and L minimum. Diameter is uncontrolled in L1 and beyond LL minimum.
- All three leads.
- Radius (r) applies to both inside corners of tab.
- Drain is electrically connected to the case.
- In accordance with ASME Y14.5M, diameters are equivalent to ϕ x symbology.

FIGURE 1. Physical dimensions for TO-205AF.

PACKAGE DIMENSIONS

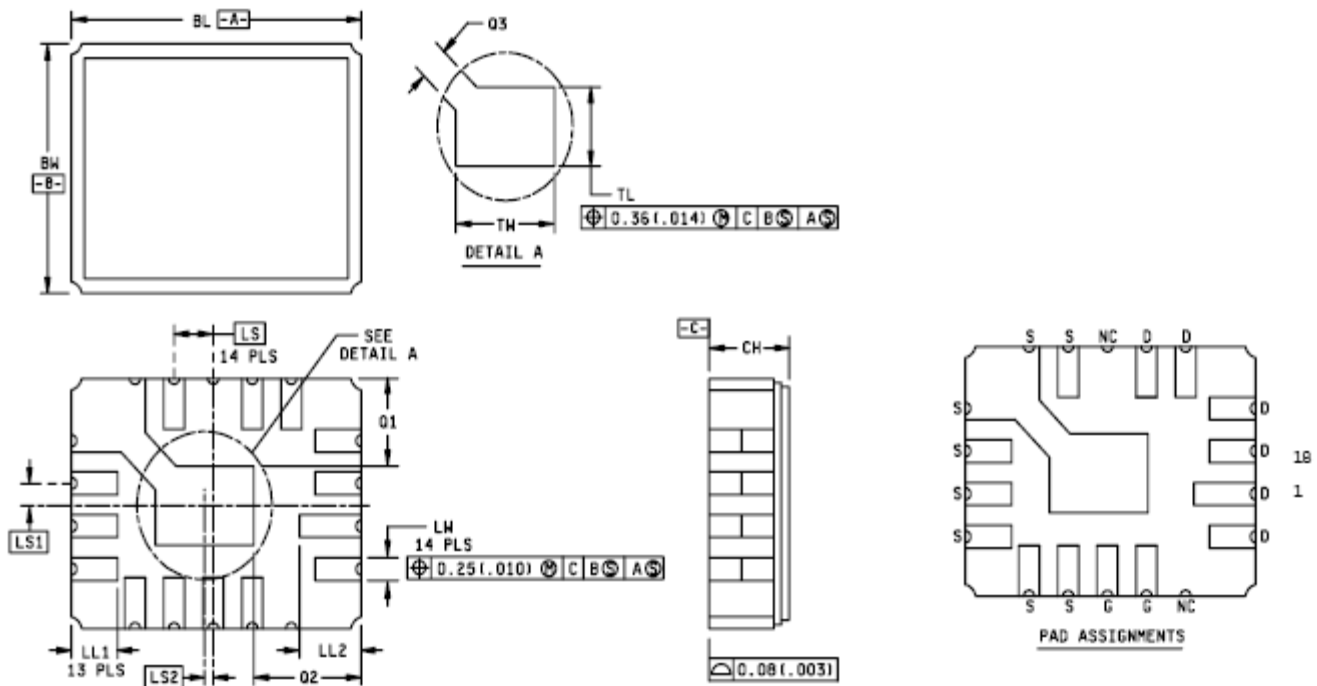

NOTES:

- 1 Dimensions are in inches.
- 2 Millimeters are given for general information only.
- 3 In accordance with ASME Y14.5M, diameters are equivalent to ϕx symbology.
- 4 Ceramic package only.

Ltr	Dimensions			
	Inches		Millimeters	
	Min	Max	Min	Max
BL	.345	.360	8.77	
BW	.280	.295	7.11	
CH	.095	.115	2.41	
LL1	.040	.055	1.02	
LL2	.055	.065	1.40	
LS	.050 BSC		1.27 BSC	
LS1	.025 BSC		0.635 BSC	
LS2	.008 BSC		0.203 BSC	
LW	.020	.030	0.51	0.76
Q1	.105 REF		2.67 REF	
Q2	.120 REF		3.05 REF	
Q3	.045	.055	1.14	1.40
TL	.070	.080	1.78	2.03
TW	.120	.130	3.05	3.30

FIGURE 2. Physical dimensions for LCC.