

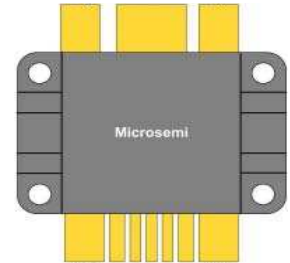

## MOSFET Driver Hybrid

The DRF1200 hybrid includes a high power gate driver and the power MOSFET. The driver output can be configured as Inverting and Non-Inverting. It was designed to provide the system designer increased flexibility and lowered cost over a non-integrated solution.

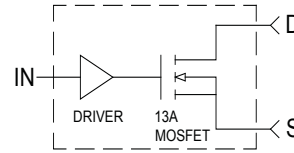

### FEATURES

- Switching Frequency: DC TO 30MHz
- Low Pulse Width Distortion
- Single Power Supply
- 1V CMOS Schmitt Trigger Input 1V Hysteresis
- Inverting Non-Inverting Select
- RoHS Compliant 
- Switching Speed 3-4ns
- $B_{V_{ds}} = 1Kv$
- $I_{ds} = 13A$  Max
- $R_{ds(on)} \leq 0.90$  Ohm
- $P_D = 624W$

### TYPICAL APPLICATIONS

- Class C, D and E RF Generators
- Switch Mode Power Amplifiers
- Pulse Generators
- Ultrasound Transducer Drivers
- Acoustic Optical Modulators

### Driver Absolute Maximum Ratings

Symbol	Parameter	Min	Typ	Max	Unit
$V_{DD}$	Supply Voltage			15	V
IN, FN	Input Single Voltages			-.7 to +5.5	
$I_{O_{PK}}$	Output Current Peak			8	A
$T_{JMAX}$	Operating Temperature			175	°C

### Driver Specifications

Symbol	Parameter	Min	Typ	Max	Unit
$V_{DD}$	Supply Voltage	10		15	V
IN	Input Voltage	3		5.5	
$IN_{(R)}$	Input Voltage Rising Edge		3		ns
$IN_{(F)}$	Input Voltage Falling Edge		3		
$I_{DDQ}$	Quiescent Current		2		mA
$I_O$	Output Current		8		A
$C_{iss}$	Input Capacitance		3		
$R_{IN}$	Input Parallel Resistance		1		MΩ
$V_{TH(on)}$	Input, Voltage Threshold Low (See truth table)	0.8		1.1	V
$V_{TH(off)}$	Input, Voltage Threshold High (See truth table)	1.9		2.2	
$T_{DLY}$	Time Delay (throughput)		38		ns
$t_r$	Rise Time		7.5		ns
$t_f$	Fall Time		7.5		

## Driver Output Characteristics

Symbol	Parameter	Min	Typ	Max	Unit
$C_{out}$	Output Capacitance		2500		pF
$R_{out}$	Output Resistance		.8		$\Omega$
$L_{out}$	Output Inductance		3		nH
$F_{MAX}$	Operating Frequency $CL = 3000nF + 50\Omega$	30			MHz
$F_{MAX}$	Operating Frequency $RL = 50\Omega$	50			

## Driver Thermal Characteristics

Symbol	Parameter	Min	Typ	Max	Unit
$R_{\theta JC}$	Thermal Resistance Junction to Case		1.5		$^{\circ}C/W$
$R_{\theta JHS}$	Thermal Resistance Junction to Heat Sink		2.5		
$T_{JSTG}$	Storage Temperature		-55 to 150		$^{\circ}C$
$P_{DJHS}$	Maximum Power Dissipation @ $T_{SINK} = 25^{\circ}C$		60		W
$P_{DJC}$	Total Power Dissipation @ $T_C = 25^{\circ}C$		100		

## MOSFET Absolute Maximum Ratings

Symbol	Parameter	Min	Typ	Max	Unit
$BV_{DSS}$	Drain Source Voltage	1000			V
$I_D$	Continuous Drain Current $T_{HS} = 25^{\circ}C$			13	A
$R_{DS(on)}$	Drain-Source On State Resistance		0.90		$\Omega$
$T_{Jmax}$	Operating Temperature			175	$^{\circ}C$

## MOSFET Dynamic Characteristics

Symbol	Parameter	Min	Typ	Max	Unit
$C_{iss}$	Input Capacitance		2000		pF
$C_{oss}$	Output Capacitance		165		
$C_{rss}$	Reverse Transfer Capacitance		75		

## MOSFET Thermal Characteristics

Symbol	Parameter	Min	Typ	Max	Unit
$R_{\theta JC}$	Thermal Resistance Junction to Case		0.095		$^{\circ}C/W$
$R_{\theta JHS}$	Thermal Resistance Junction to Heat Sink		0.25		
$T_{JSTG}$	Storage Temperature		-55 to 150		$^{\circ}C$
$P_{DHS}$	Maximum Power Dissipation @ $T_{SINK} = 25^{\circ}C$		600		W
$P_{DC}$	Total Power Dissipation @ $T_C = 25^{\circ}C$		1580		

Microsemi reserves the right to change, without notice, the specifications and information contained herein.

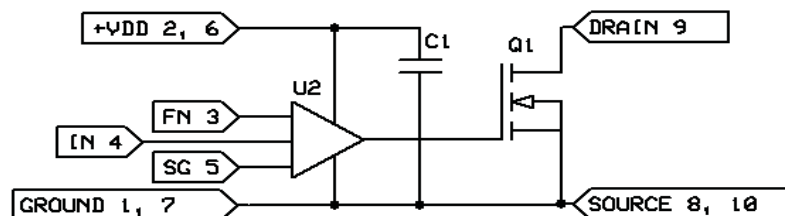

Figure 1, DRF1200 Simplified Circuit Diagram

The Simplified DRF1200 Circuit Diagram is illustrated above. By including the driver high speed by-pass capacitor (C1), the contribution to the internal parasitic loop inductance of the driver output is greatly reduced. This, coupled with the tight geometry of the hybrid, allows optimal gate drive to the MOSFET. This low parasitic approach, coupled with the Schmitt trigger input (IN), Kelvin signal ground (SG) and the Anti-Ring Function, provide improved stability and control in Kilowatt, high Frequency applications. Both the FN and IN pins are referenced to the Kelvin ground (SG.) The signal is then applied to the intermediate drivers and level shifters; this section contains proprietary circuitry designed specifically for the ring abatement. The power drivers provide high current to the gate of the MOSFETS.

The Function (FN, pin 3) is the invert or non-invert select Pin, it is Internally held high.

Truth Table *Referenced to SG		
FN (pin 3)*	IN (pin 4)*	MOSFET
HIGH	HIGH	ON
HIGH	LOW	OFF
LOW	HIGH	OFF
LOW	LOW	ON

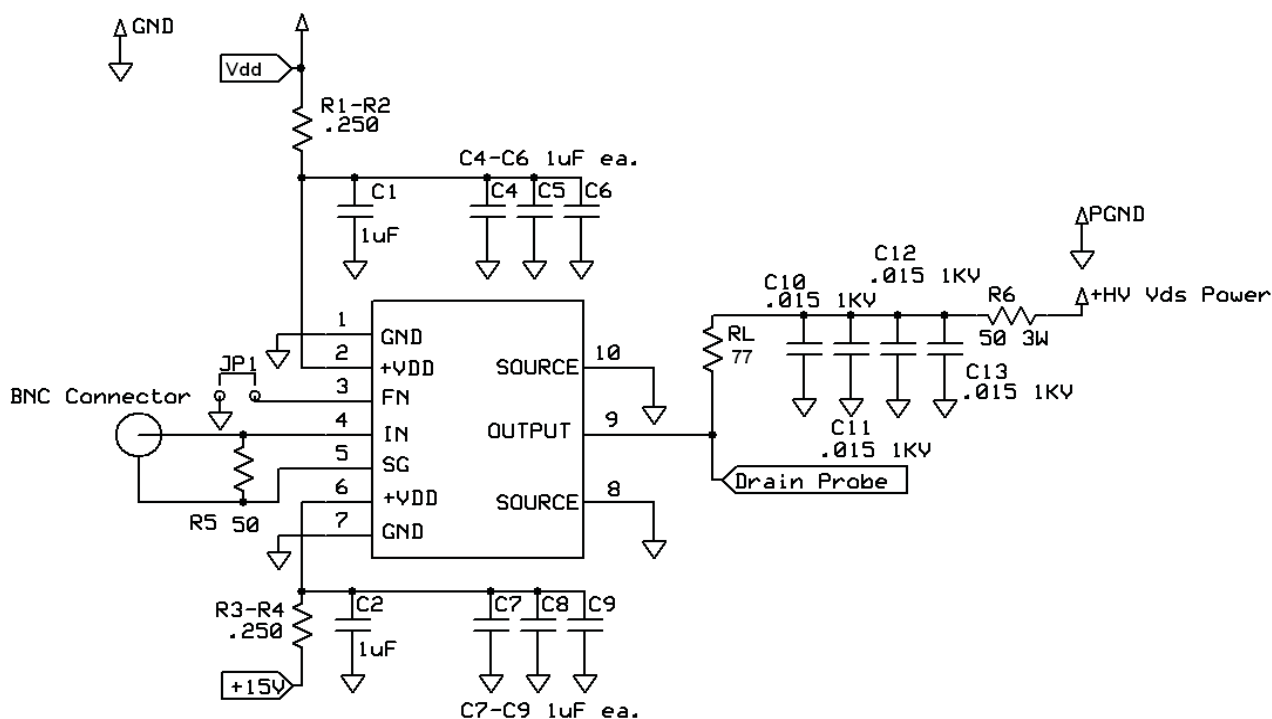

Figure 2, DRF1200 Test Circuit

The Test Circuit illustrated above was used to evaluate the DRF1200 (available as an evaluation Board DRF12XX / EVALSW.) The input control signal is applied to the DRF1200 via IN(4) and SG(5) pins using RG188. This provides excellent noise immunity and control of the signal ground currents.

The  $+V_{DD}$  inputs (2,6) are by-passed (C1, C2, C4-C9), this is in addition to the internal by-passing mentioned previously. The capacitors used for this function must be capable of supporting the RMS currents and frequency of the gate load.  $R_L$  set for  $I_{DM}$  at  $V_{DS}$  max this load is used to evaluate the output performance of the DRF1201.

