

MINIATURE LED DRIVER LX1995 EVALUATION KIT

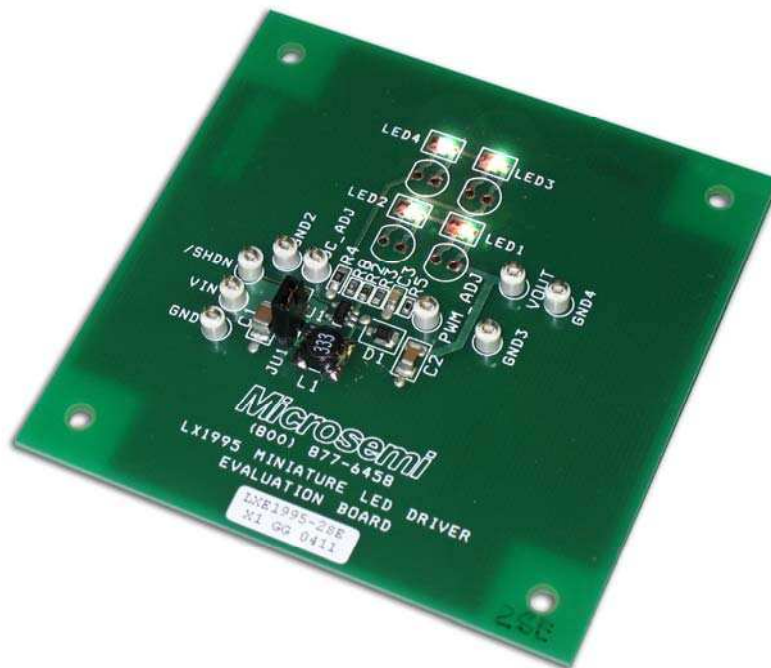

TABLE OF CONTENTS

LX1995 EVAL Introduction3
Schematic for LX1995 Evaluation Board4
Hook up5
Connections6
Printed Circuit Board7
Bill of Materials8

INTRODUCING TO PRODUCT

The LX1995 Evaluation Board (EB) is available from Microsemi for evaluating the performance of the LX1995 LED driver integrated circuit. (See picture 1) The EB contains a small amount of support circuitry that enhances performance in different dimming configurations. (See schematic 1.) In a typical application, some of this circuitry would be eliminated.

KEY FEATURES OF THE LX1995

- < 1 μ A Shutdown Current
- > 85% Maximum Efficiency
- Efficient at Low Current Levels
- < 70 μ A Quiescent Supply Current in Operating Mode
- V_{IN} Range 1.6V to 5.5V
- Logic Controlled Shutdown
- Dimming Options: PWM or Varying DC Voltage
- Tiny 5-Pin TSOT Package
- Smallest External Components

APPLICATIONS

- Pagers
- Wireless Phones
- PDAs
- LED Driver
- Digital Camera Displays
- GPS Receivers

PART SPECIFIC INFORMATION

Part Number	Switch Current	Description
LX1995-1CSG	325mA	High Efficiency LED Driver
LX1995-1CSE		
LX1995-2CSG	500mA	
LX1995-2CSE		

Table 1 – Part Information

IC	EVALUATION BOARDS
LX1995-1CSG	LX1995-1SG EVAL
LX1995-1CSE	LX1995-1SE EVAL
LX1995-2CSG	LX1995-2SG EVAL
LX1995-2CSE	LX1995-2SE EVAL

Table 2 – Evaluation Board Information

SCHEMATIC FOR LX1995 EVAL

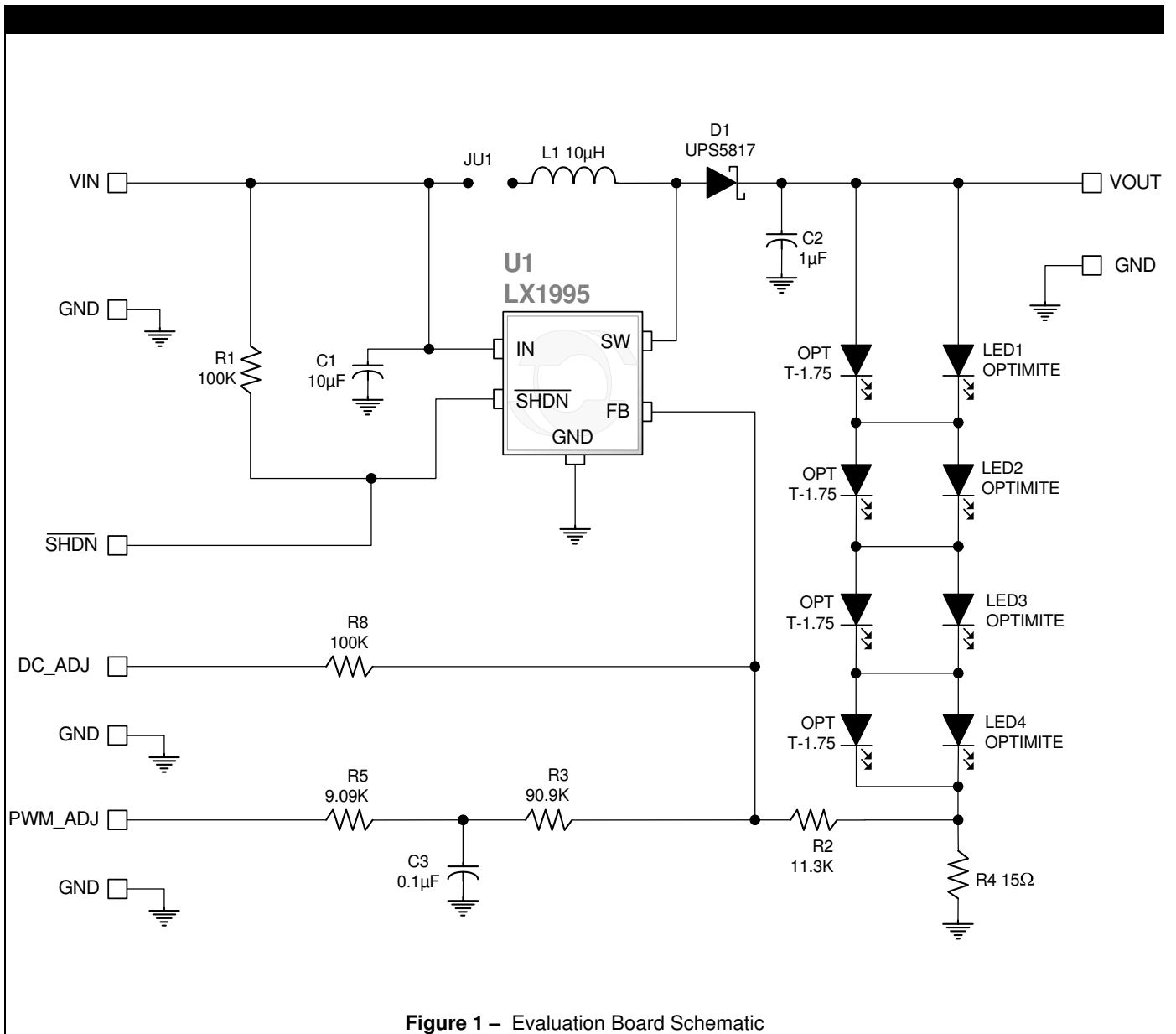

Figure 1 – Evaluation Board Schematic

LX1995 EVALUATION HOOK UP

The following is a demonstration scenario that can be used to evaluate the LX1995:

Directions for hook up (DC dimming mode):

1. Install jumper JU1.

2. Connect a 3.6V typical 1A power source between VIN and GND terminals.
3. Apply a 1.5V DC signal to the DC_ADJ terminal. Signal GND can be referenced to GND2 for convenience.
4. Vary the DC signal from 0V to 3V and observe the LEDs dimming. (Measure LED current from LED4 cathode to GND2 if desired. $I = V / 15$.)

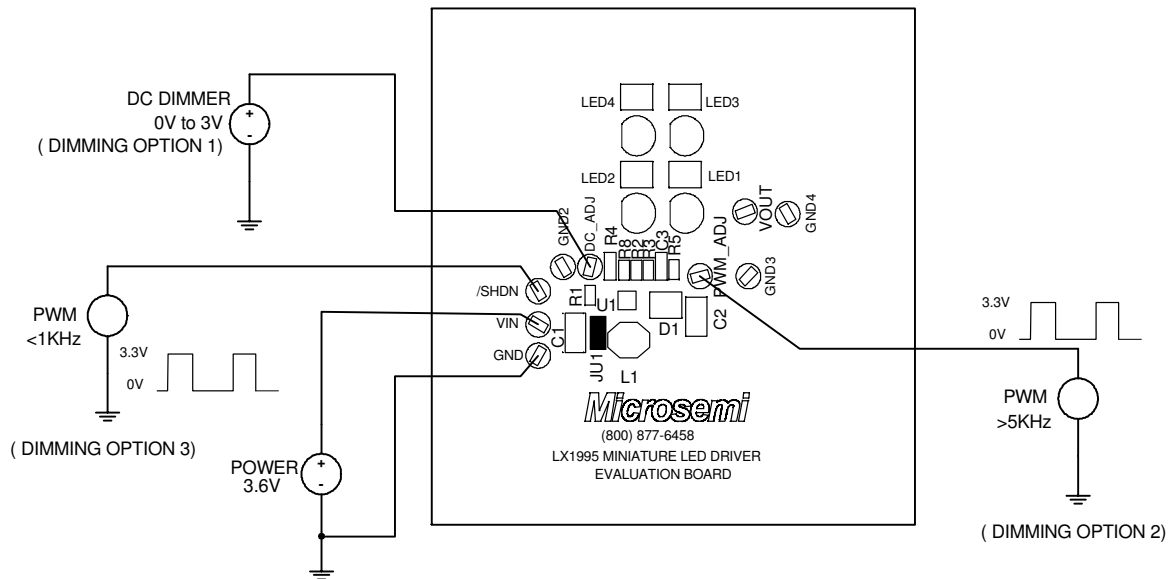

Figure 2 – Typical Hook Up for the LX1995 Eval Board

CONNECTIONS

The LX1995 Evaluation Board has 9 test lead attachment point for applying power and dimming inputs or for monitoring voltages.

Function	Board Label	Connection
Input Power	VIN	Power supply (3.55V+/- 1.95V).
Power Ground	GND	Common power supply ground.
Enable	/SHDN	Connect to GND to disable LX1995. A <1KHz logic PWM signal can also be applied.
DC dimming	DC_ADJ	Apply a 0 to 3V DC dimming input
PWM dimming	PWM_ADJ	Apply a >5KHz 3.3V logic PWM signal.
Output Voltage	VOUT	Test point to monitor voltage across all LEDs.
Signal Ground	GND#	Multiple common grounds for probes. etc

Table 3 – Connection Points

Hints: For best results, use only one of the three possible LED dimming methods at a time. LED current can be monitored by measuring the voltage from LED4 cathode to GND and dividing by 15 (the value of R4).

NOTE: Jumper JU1 must be connected for the LX1995 to function. This jumper can be replaced with a wire loop so the inductor current waveform can be observed using a current probe.

PRINTED CIRCUIT BOARD LAYOUT

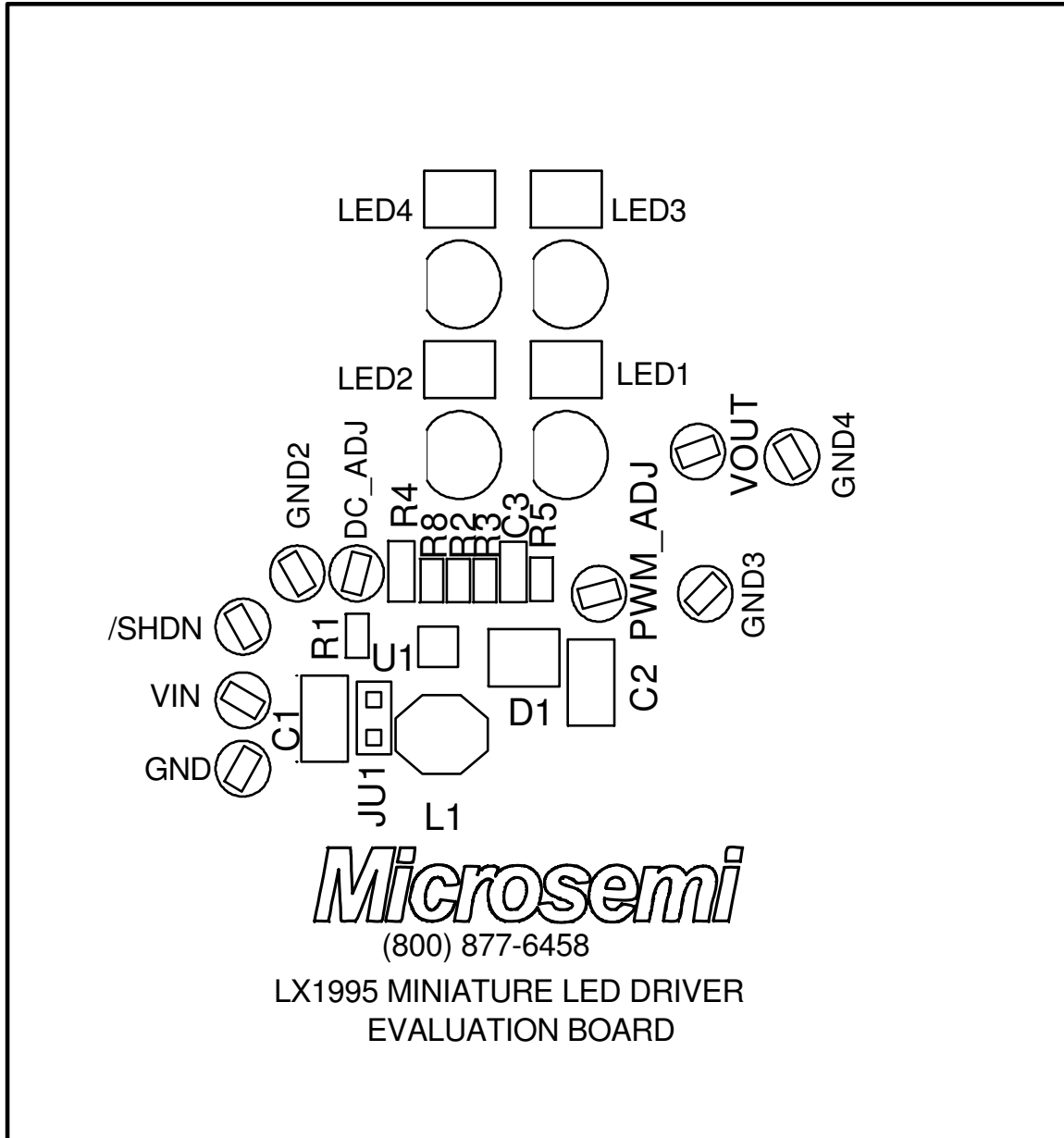

Figure 3 – LX1995 Evaluation Board

BILL OF MATERIALS

MISCELLANEOUS COMPONENTS

Line Item	Part Description	Manufacturer & Part #	Case	Reference Designators	Qty
1	Miniature LED Driver	MICROSEMI LX1995-xCyy		U1	1
2	LED, White	MICROSEMI UPWLED	0603	LED#	4
3	Diode, Schottky, 20V, 1A	MICROSEMI UPS5817	Powermite	D1	1
4	Inductor, 10 μ H	COILCRAFT LPO3310-103MX		L1	1
5	Jumper				1
6	3-Pin Header, .100				1
7	Lead Attachment HW				9

x – denotes switch current
yy – denotes Package Type

CAPACITORS

Line Item	Part Description	Part Description	Case	Reference Designators	Qty
1	Capacitor, 10 μ F, 6.3V, X5R	MURATA GRM319R60J106ME01D	1206	C1	1
2	Capacitor, 1.0 μ F, 50V, X7R	MURATA C3216X7R1H105K	1206	C2	1
3	Capacitor, 0.1 μ F, 50V, X7R	MURATA GRM21BR71H104KA01L	0805	C3	1

RESISTORS

Line Item	Part Description	Part Description	Case	Reference Designators	Qty
1	Resistor, 100K	PANASONIC ERJ-3EKF1003V	0603	R1, R8	2
2	Resistor, 11.3K	PANASONIC ERJ-3EKF1132V	0603	R2	1
3	Resistor, 90.9K	PANASONIC ERJ-3EKF9092V	0603	R3	1
4	Resistor, 15	PANASONIC ERJ-6ENF15R0V	0805	R4	1
5	Resistor, 9.09K	PANASONIC ERJ-3EKF9091V	0603	R5	1