

# Military Silicon Power Rectifier

## 1N1124A–1N1128A, 1N3649, 1N3650

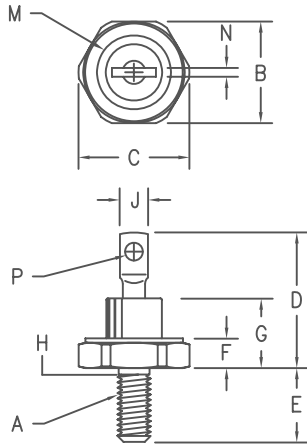

**Notes:**

1. 10–32 UNF3A
2. Full threads within 2 1/2 threads
3. Standard Polarity: Stud is Cathode  
Reverse Polarity: Stud is Anode

Dim.	Inches		Millimeter		Notes
	Minimum	Maximum	Minimum	Maximum	
A	---	---	---	---	1
B	.424	.437	10.77	11.10	
C	---	.505	---	12.83	
D	---	.800	---	20.32	
E	.422	.453	10.72	11.51	
F	.075	.175	1.91	4.44	
G	---	.405	---	10.29	
H	.163	.189	4.15	4.80	2
J	.100	.140	2.54	3.56	
M	---	.350	---	8.89	Dia
N	.020	.065	.510	1.65	
P	.070	.100	1.78	2.54	Dia

### D0203AA (D04)

Standard	Microsemi Catalog Number	Reverse	Peak Reverse Voltage
1N1124A	1N1124A	1N1124RA	200V
1N1126A	1N1126A	1N1126RA	400V
1N1128A	1N1128A	1N1128RA	600V
1N3649	1N3649	1N3649R	800V
1N3650	1N3650	1N3650R	1000V

- Available in JAN
- MIL-PRF-19500/260
- Glass passivated die
- Glass to metal seal construction
- 25 Amps surge rating
- $V_{RRM}$  to 1000 volts

### Electrical Characteristics

Average forward current	IF(AV) 3.3 Amps	$T_C = 150^\circ\text{C}$ , half sine wave, $R_{\theta JC} = 2.0^\circ\text{C/W}$ 8.3ms, half sine, $T_C = 150^\circ\text{C}$ $I_{FM} = 10\text{A}$ : $T_J = 25^\circ\text{C}$ * $V_{RRM, T_J} = 25^\circ\text{C}$ $V_{RRM, T_J} = 150^\circ\text{C}$
Maximum surge current	IFSM 25 Amps	
Max peak forward voltage	V <sub>FM</sub> 2.2 Volts	
Max peak reverse current	I <sub>RM</sub> 5 $\mu\text{A}$	
Max peak reverse current	I <sub>RM</sub> 200 $\mu\text{A}$	
Max Recommended Operating Frequency	10kHz	

\*Pulse test: Pulse width 300  $\mu\text{sec}$ . Duty cycle 2%

### Thermal and Mechanical Characteristics

Storage temperature range	T <sub>STG</sub>	-65°C to 200°C
Operating case temp range	T <sub>C</sub>	-65°C to 150°C
Maximum thermal resistance	R <sub><math>\theta</math>JC</sub>	2.0°C/W Junction to Case
Mounting torque		15 inch pounds maximum
Weight		.16 ounces (5.0 grams) typical

# 1N1124A-1N1128A, 1N3649, 1N3650

Figure 1  
Typical Forward Characteristics

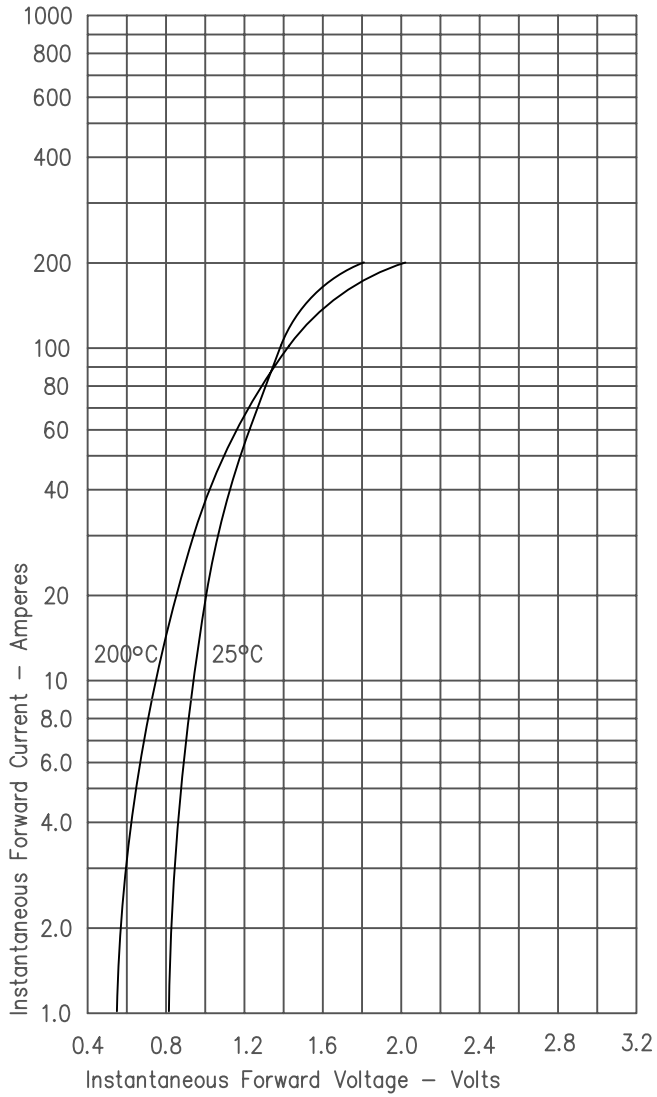

Figure 2  
Typical Reverse Characteristics

