

LOW-VOLTAGE SUPERVISORY CIRCUIT

DESCRIPTION

This device was designed to provide all the operational features of the SG1543/2543/3543 devices but with the added advantage of uncommitted inputs to the voltage sensing comparators. This allows monitoring of voltage levels less than 2.5 volts by dividing down the internal reference supply.

In all other respects, the SG1544 series is identical to the SG1543 series. These monolithic devices contain all the functions necessary to monitor and control the output of a sophisticated power supply system. Over-voltage sensing with provision to trigger an external SCR "crowbar" shutdown; an under-voltage circuit which can be used to monitor either the output or sample the input line voltage; and a third op amp/comparator usable for current sensing are all included in this IC, together with an independent, accurate reference generator.

The voltage-sensing input comparators are identical and can be used with threshold levels from zero volts to ($V_{IN} - 3V$). Each has approximately 25mv of hysteresis which is offset so the switching differential threshold is zero on the non-inverting input for rising levels and zero on the inverting input for falling signals. All other operating characteristics are as described in the SG1543 data sheet and application note.

FEATURES

- Uncommitted comparator inputs for wide input flexibility
- Common-Mode range from zero to near supply voltage
- Reference voltage trimmed to 1% accuracy
- Over-voltage, under-voltage, and current sensing circuits all included
- SCR "Crowbar" drive of 300mA
- Programmable time delays
- Open-collector outputs and remote activation capability
- Total standby current less than 10mA

HIGH RELIABILITY FEATURES - SG1544

- ◆ Available to MIL-STD-883 and DESC SMD
- ◆ LMI level "S" processing available

BLOCK DIAGRAM

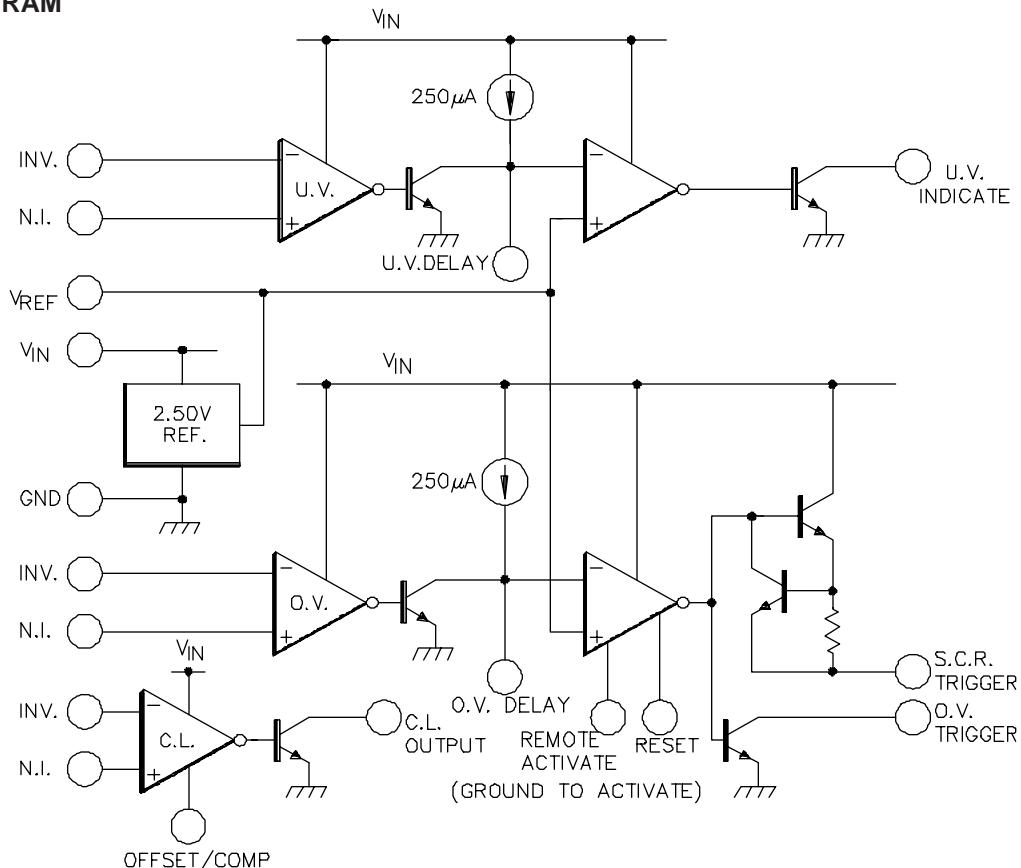

ABSOLUTE MAXIMUM RATINGS (Note 1)

Input Supply Voltage (+V _{IN})	40V	Indicator Output Sink Current	50mA
Sense Inputs	+V _{IN}	Operating Junction Temperature	
SCR Trigger Current (Note 2)	300mA	Hermetic (J Package)	150°C
Indicator Output Voltage	40V	Plastic (N, DW Packages)	150°C
		Storage Temperature Range	-65°C to 150°C

Note 1. Values beyond which damage may occur.

Note 2. At higher input voltages, a dissipation limiting resistor, R_G, is required. See Figure 1.

THERMAL DATA

J Package:

Thermal Resistance-Junction to Case, θ_{JC}	25°C/W
Thermal Resistance-Junction to Ambient, θ_{JA}	70°C/W

N Package:

Thermal Resistance-Junction to Case, θ_{JC}	30°C/W
Thermal Resistance-Junction to Ambient, θ_{JA}	60°C/W

DW Package:

Thermal Resistance-Junction to Case, θ_{JC}	35°C/W
Thermal Resistance-Junction to Ambient, θ_{JA}	90°C/W

RoHS Peak Package Solder Reflow (40 sec. max. exp.)...260°C (+0, -5)

Note A. Junction Temperature Calculation: $T_J = T_A + (P_D \times \theta_{JA})$.

Note B. The above numbers for θ_{JC} are maximums for the limiting thermal resistance of the package in a standard mounting configuration. The θ_{JA} numbers are meant to be guidelines for the thermal performance of the device/pc-board system. All of the above assume no ambient airflow.

RECOMMENDED OPERATING CONDITIONS (Note 3)

Input Supply Voltage (+V _{IN})	4.7V to 40V	Delay Timing Capacitor (Note 4)	0 to 1 μ F
Current Limit Common Mode		Operating Ambient Temperature Range	
Input Voltage Range	0V to +V _{IN} -3V	SG1544	-55°C to 125°C
Reference Load Current	0 to 10mA	SG2544	-25°C to 85°C
Indicator Output Voltage	4.7V to 40V	SG3544	0°C to 70°C
Indicator Output Current	0 to 10mA		

Note 3: Range over which the device is functional.

Note 4: Larger value capacitor may be used with peak current limiting. See Figure 1.

ELECTRICAL CHARACTERISTICS

(Unless otherwise specified, these specifications apply over the operating ambient temperatures for SG1544 with $-55^\circ\text{C} \leq T_A \leq 125^\circ\text{C}$, SG2544 with $-25^\circ\text{C} \leq T_A \leq 85^\circ\text{C}$, SG3544 with $0^\circ\text{C} \leq T_A \leq 70^\circ\text{C}$, and +V_{IN} = 10V. Indicator outputs have 2k Ω pull-up resistors. All electrical ratings and specifications are tested with the inverting over-voltage input and the non-inverting under-voltage input externally connected to the 2.5V reference. Low duty cycle testing techniques are used which maintains junction and case temperatures equal to the ambient temperature.)

Parameter	Test Conditions	SG1544/2544			SG3544			Units
		Min.	Typ.	Max.	Min.	Typ.	Max.	
Supply Section								
Input Voltage Range	T _J = 25°C to T _{MAX}	4.5		40	4.5		40	V
		4.7		40	4.7		40	V
Supply Current	+V _{IN} = 40V, Outputs open		7	10		7	10	mA
Reference Section								
Output Voltage	T _J = 25°C	2.48	2.50	2.52	2.45	2.50	2.55	V
		2.45		2.55	2.40		2.60	V
Line Regulation	+V _{IN} = 5 to 30V		1	5		1	5	mV
Load Regulation	I _{REF} = 0 to 10mA		1	10		1	10	mV
Short Circuit Current	V _{REF} = 0V	12	25	40	12	25	40	mA
Temperature Stability			.005			.005		%/°C

ELECTRICAL CHARACTERISTICS (continued)

Parameter	Test Conditions	SG1544/2544			SG3544			Units
		Min.	Typ.	Max.	Min.	Typ.	Max.	
Comparator Section								
Input Threshold (Note 5)	$T_J = 25^\circ\text{C}$	2.45	2.50	2.55	2.40	2.50	2.60	V
		2.40		2.60	2.35		2.65	V
Input Hysteresis			25			25		mV
Input Bias Current	Sense input = 0V		0.3	1.0		0.3	1.0	μA
Delay Saturation			0.2	0.5		0.2	0.5	V
Delay High Level			6	8		6	8	V
Delay Charging Current	$V_D = 0\text{V}$	200	250	300	200	250	300	μA
Indicate Saturation	$I_L = 10\text{mA}$		0.2	0.5		0.2	0.5	V
Indicate Leakage	$V_{\text{IND}} = 40\text{V}$.01	1.0		0.1	1.0	μA
Propagation Delay	$V_{\text{O.V. N.I. IN}} = 2.7\text{V}$, $V_{\text{U.V. INV. IN}} = 2.3\text{V}$, $T_J = 25^\circ\text{C}$							
	$C_D = 0$		400			400		ns
	$C_D = 1\mu\text{F}$		10			10		ms
SCR Trigger Section								
Peak Output Current	$+V_{\text{IN}} = 5\text{V}$, $R_G = 0$, $V_O = 0$	100	200	400	100	200	400	mA
Peak Output Voltage	$+V_{\text{IN}} = 15\text{V}$, $I_O = 100\text{mA}$	12	13		12	13		V
Output Off Voltage	$+V_{\text{IN}} = 40\text{V}$, $R_L = 1\text{K}\Omega$		0	0.1		0	0.1	V
Remote Activate Current	REM. ACT. pin = Gnd		0.4	0.8		0.4	0.8	mA
Remote Activate Voltage	REM. ACT pin open		2	6		2	6	V
Reset Current	RESET pin = Gnd, REM. ACT. = Gnd		0.4	0.8		0.4	0.8	mA
Reset Voltage	RESET pin open, REM. ACT. = Gnd		2	6		2	6	V
Output Current Rise Time	$R_L = 50\Omega$, $T_J = 25^\circ\text{C}$, $C_D = 0$		400			400		mA/ μs
Prop. Delay from REM. ACT. Pin	$V_{\text{REM. ACT.}} = 0.4\text{V}$		300			300		ns
Prop. Delay fom O.V. N.I. IN Pin	$V_{\text{O.V. N.I. INPUT}} = 2.7\text{V}$		500			500		ns
Current Limit Section								
Input Voltage Range		0		$V_{\text{IN}} -3\text{V}$	0		$V_{\text{IN}} -3\text{V}$	V
Input Bias Current	OFFSET/COMP pin open, $V_{\text{CM}} = 0\text{V}$		0.3	1.0		0.3	1.0	μA
Input Offset Voltage	OFFSET/COMP pin open, $V_{\text{CM}} = 0\text{V}$		0	10		0	15	mV
	10Ω from OFFSET/COMP pin to Gnd, $T_J = 25^\circ\text{C}$	80	100	120	70	100	130	mV
CMRR	$0 \leq V_{\text{CM}} \leq 12\text{V}$, $V_{\text{IN}} = 15\text{V}$	60	70		60	70		dB
AVOL	OFFSET/COMP pin open, $V_{\text{CM}} = 0\text{V}$	72	80		72	80		dB
Output Saturation	$I_L = 10\text{mA}$		0.2	0.5		0.2	0.5	V
Output Leakage	$V_{\text{IND}} = 40\text{V}$.01	1.0		.01	1.0	μA
Small Signal Bandwidth	$A_V = 0\text{dB}$, $T_J = 25^\circ\text{C}$		5			5		MHz
Propagation Delay	$V_{\text{OVERDRIVE}} = 100\text{mV}$, $T_J = 25^\circ\text{C}$		200			200		ns

Note 5. Input voltage rising on O.V. N.I. INPUT and falling on U.V. INV. INPUT.

APPLICATION INFORMATION

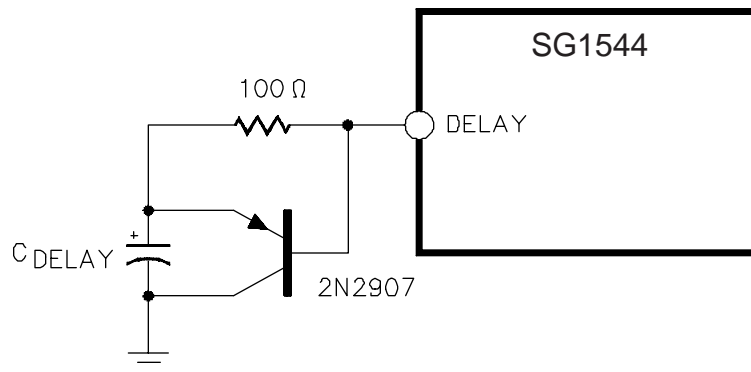
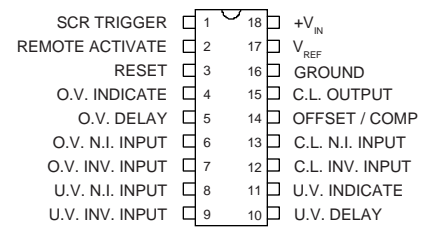
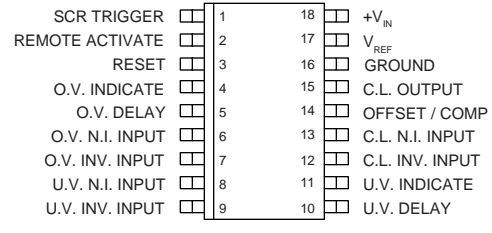

FIGURE 1 - SURGE LIMIT CIRCUIT FOR LARGE DELAY CAPACITORS

The 100 ohm resistor limits the peak discharge current into the SG1544 while the external PNP transistor provides a high peak-current discharge path for the delay capacitor.

CONNECTION DIAGRAMS & ORDERING INFORMATION (See Notes Below)

Package	Part No.	Ambient Temperature Range	Connection Diagram
18-PIN CERAMIC DIP J - PACKAGE	SG1544J/883B SG1544JDESC SG1544J SG2544J SG3544J	-55°C to 125°C -55°C to 125°C -55°C to 125°C -25°C to 85°C 0°C to 70°C	
18-PIN PLASTIC DIP N - PACKAGE	SG2544N SG3544N	-25°C to 85°C 0°C to 70°C	
		N Package: RoHS / Pb-free 100% Matte Tin lead Finish	N Package: RoHS Compliant / Pb-free Transition DC: 0503
18-PIN WIDE BODY PLASTIC S.O.I.C. DW - PACKAGE	SG2544DW SG3544DW	-25°C to 85°C 0°C to 70°C	
		DW Package: RoHS / Pb-free 100% Matte Tin lead Finish	DW Package: RoHS Compliant / Pb-free Transition DC: 0516

Note 1. Contact factory for JAN and DESC product availability.
 2. All packages are viewed from the top.