

**DESCRIPTION**

The LX6431 series precision adjustable three terminal shunt voltage regulators are pin-to-pin compatible with the industry standard TL431, but with significant improvements. The LX6431 design has eliminated regions of instability common to older generation shunt regulator products like the TL431. Designs are made simpler by eliminating the task of insuring capacitive loads, and output voltage and cathode currents don't combine for unstable operation. The capacitor value is chose simply to give the best load transient response without the possibility of instability. A lower reference input current allows the use of higher value reference divider resistors, reducing the current drain from batteries in portable

equipment as well as reducing the voltage programming errors due to the impedance of the divider network (See product Highlight)

In addition, the LX6431B has an improved initial accuracy of 0.4%, and the output voltage is programmable by using two external resistors from 2.5V to 36V.

These devices offer low output impedance for improved load regulation. The typical output impedance of these devices is 100mΩ. The reduced reference input bias current and minimum operating currents make these devices suitable for portable and micro power applications.

**KEY FEATURES**

- Unconditionally Stable for All Cathode To Anode Capacitance Values
- Reduced Reference Input Current Allowing The Use of Higher Value Divider Resistors (0.5μA)
- Initial Voltage Reference Accuracy of 0.4% (LX6431B)
- Sink Current Capability 0.6mA to 100mA
- Typical Output Dynamic Impedance Less Than 100mΩ
- Adjustable Output Voltage From 2.5V to 36V

**IMPORTANT:** For the most current data, consult MICROSEMI's website: <http://www.microsemi.com>

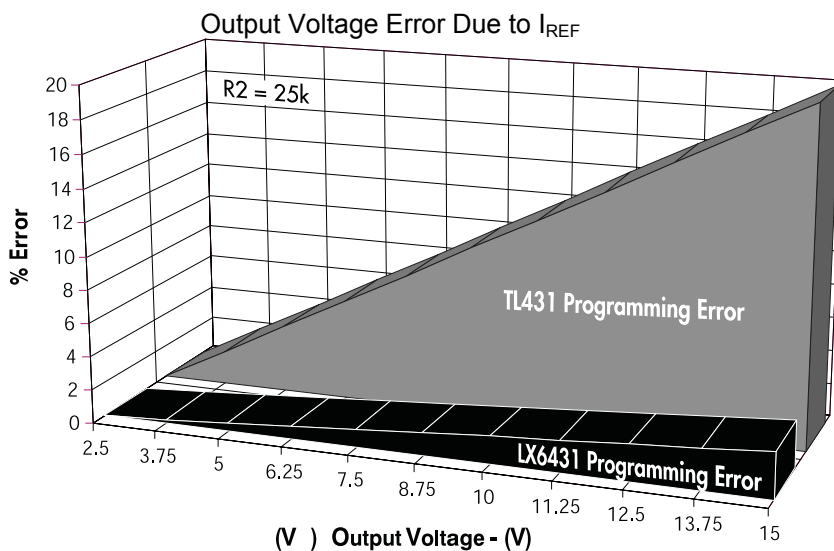
**PRODUCT HIGHLIGHT**

TYPICAL PROGRAMMABLE VOLTAGE REFERENCE CIRCUIT

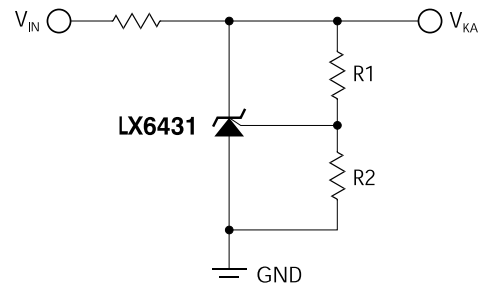
**PACKAGE ORDER INFO**

T <sub>A</sub> (°C)	Initial Tolerance	PK	DM	LP
		Plastic TO-89 3-Pin RoHS Compliant / Pb-free Transition D/C: 0518	Plastic SOIC 8-Pin RoHS Compliant / Pb-free Transition D/C: 0440	Plastic TO-92 3-Pin RoHS Compliant / Pb-free Transition D/C: 0509
0 to 70	2%	LX6431CPK	LX6431CDM	LX6431CLP
	1%	LX6431ACPK	LX6431ACDM	LX6431ACLCP
	0.4%	LX6431BCPK	LX6431BCDM	LX6431BCLP
-40 to 85	2%	LX6431IPK	LX6431IDM	LX6431ILP
	1%	LX6431AIPK	LX6431AIDM	LX6431AILP
	0.4%	LX6431BIPK	LX6431BIDM	LX6431BILP

Note: Available in Tape & Reel. Append the letters "TR" to the part number. (i.e. LX6431CDM-TR)

**ABSOLUTE MAXIMUM RATINGS**

Cathode to Anode Voltage ( $V_{KA}$ ).....	-0.3V to 37V
Reference Input Current ( $I_{REF}$ ).....	-50 $\mu$ A to 10 $\mu$ A
Continuous Cathode Current ( $I_K$ ).....	-100mA to 150mA
Operating Temperature Range.....	150°C
Maximum Operating Junction Temperature Plastic (DM & LP Packages) .....	150°C
Storage Temperature Range.....	-65°C to 150°C
Package Peak Temp. for Solder Reflow (40 seconds maximum exposure) ...	260°C (+0 -5)

Note: Exceeding these ratings could cause damage to the device. All voltages are with respect to Ground. Currents are positive into, negative out of specified terminal.  
Pin numbers refer to DIL packages only.

**THERMAL DATA**
**DM** Plastic SOIC 8-Pin

THERMAL RESISTANCE-JUNCTION TO AMBIENT, $\theta_{JA}$	165°C/W
---	---------

**LP** Plastic TO-92 3-Pin

THERMAL RESISTANCE-JUNCTION TO AMBIENT, $\theta_{JA}$	156°C/W
---	---------

**PK** Plastic TO-89 3-Pin

THERMAL RESISTANCE-JUNCTION TO TAB, $\theta_{JT}$	35°C/W
THERMAL RESISTANCE-JUNCTION TO AMBIENT, $\theta_{JA}$	71°C/W

Junction Temperature Calculation:  $T_J = T_A + (P_D \times \theta_{JA})$ .

The  $\theta_{JA}$  numbers are guidelines for the thermal performance of the device/pc-board system. All of the above assume no ambient airflow.

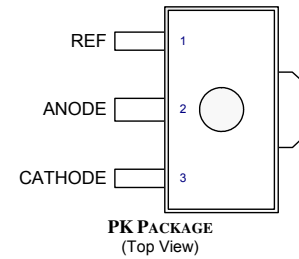
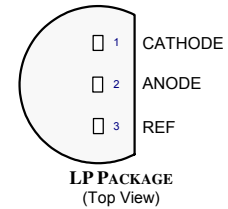
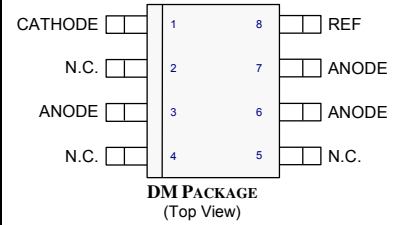
**PACKAGE PIN OUT**

N.C. – No Connection

RoHS / Pb-free 100% Matte Tin Lead Finish

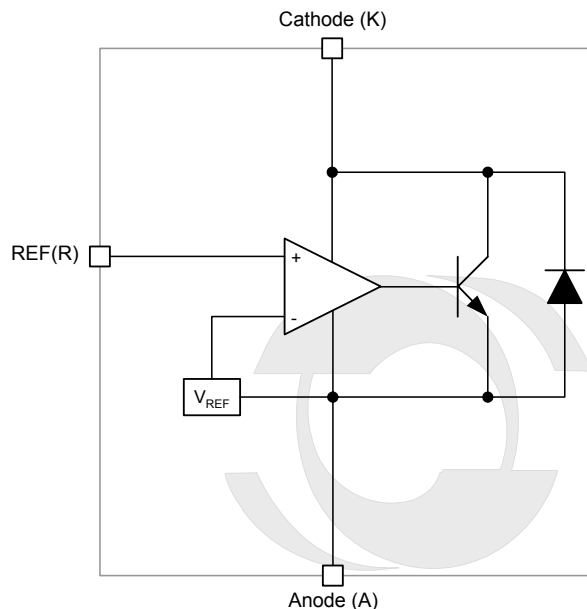
**SIMPLIFIED BLOCK DIAGRAM**

# LX6431/ LX6431A/ LX6431B

## PRECISION PROGRAMMABLE REFERENCES

### PRODUCTION DATA SHEET

#### ELECTRICAL CHARACTERISTICS (Note 2)

(Unless otherwise specified, these specifications apply over the operating ambient temperatures for LX6431C/LX6431AC/LX6431BC with  $0^{\circ}\text{C} \leq T_A \leq 70^{\circ}\text{C}$ , LX6431I/LX6431AI/LX6431BI with  $-40^{\circ}\text{C} \leq T_A \leq 85^{\circ}\text{C}$ .)

Parameter	Symbol	Test Conditions	LX6431			Units
			Min.	Typ.	Max.	
Reference Input Voltage	LX6431	$I_K = 10\text{mA}, V_{KA} = V_{REF}, T_A = 25^{\circ}\text{C}$	2440		2550	mV
	LX6431A	$I_K = 10\text{mA}, V_{KA} = V_{REF}, T_A = 25^{\circ}\text{C}$	2470		2520	mV
	LX6431B	$I_K = 10\text{mA}, V_{KA} = V_{REF}, T_A = 25^{\circ}\text{C}$	2490		2510	mV
Reference Drift	LX6431	$I_K = 10\text{mA}, V_{KA} = V_{REF}, 0^{\circ}\text{C} \leq T_A \leq 70^{\circ}\text{C}$			15	mV
		$I_K = 10\text{mA}, V_{KA} = V_{REF}, -40^{\circ}\text{C} \leq T_A \leq 85^{\circ}\text{C}$			25	mV
	LX6431A	$I_K = 10\text{mA}, V_{KA} = V_{REF}, 0^{\circ}\text{C} \leq T_A \leq 70^{\circ}\text{C}$			15	mV
		$I_K = 10\text{mA}, V_{KA} = V_{REF}, -40^{\circ}\text{C} \leq T_A \leq 85^{\circ}\text{C}$			25	mV
	LX6431B	$I_K = 10\text{mA}, V_{KA} = V_{REF}, 0^{\circ}\text{C} \leq T_A \leq 70^{\circ}\text{C}$			15	mV
		$I_K = 10\text{mA}, V_{KA} = V_{REF}, -40^{\circ}\text{C} \leq T_A \leq 85^{\circ}\text{C}$			20	mV
Voltage Ratio, Reference to Cathode (Note 3)		$I_K = 10\text{mA}, V_{KA} = 2.5\text{V to } 36\text{V}, T_A = 25^{\circ}\text{C}$		0.3	1	mV/V
		$I_K = 10\text{mA}, V_{KA} = 2.5\text{V to } 36\text{V}, T_A = \text{Operating Range}$		0.3	1	mV/V
Reference Input Current	$I_{REF}$	$V_{KA} = V_{REF}, T_A = 25^{\circ}\text{C}$		0.1	0.5	$\mu\text{A}$
		$V_{KA} = V_{REF}, T_A = \text{Operating Range}$		0.1	0.5	$\mu\text{A}$
Minimum Operating Current	$I_{MIN}$	$V_{KA} = V_{REF} \text{ to } 36\text{V}, T_A = 25^{\circ}\text{C}$		0.4	0.6	mA
		$V_{KA} = V_{REF} \text{ to } 36\text{V}, T_A = \text{Operating Range}$		0.4	0.6	mA
Off-State Cathode Current	$I_{OFF}$	$V_{KA} = 36\text{V}, V_{REF} = 0\text{V}, T_A = 25^{\circ}\text{C}$		0.3	1	$\mu\text{A}$
Dynamic Impedance	$Z_{KA}$	$V_{KA} = V_{REF}, I_K = 0.6\text{mA to } 100\text{mA}, f \leq 1\text{kHz}, T_A = 25^{\circ}\text{C}$		30	100	$\text{m}\Omega$

Note 2. These parameters are guaranteed by design.

Note 3.  $\frac{\Delta V_{REF}}{\Delta V_{KA}}$  Ratio of change in reference input voltage to the change in cathode voltage.



# LX6431/ LX6431A/ LX6431B

## PRECISION PROGRAMMABLE REFERENCES

### PRODUCTION DATA SHEET

#### GRAPH / CURVE INDEX

##### Characteristic Curves

###### FIGURE #

1. REFERENCE VOLTAGE vs. FREE-AIR TEMPERATURE
2. REFERENCE CURRENT vs. FREE-AIR TEMPERATURE
3. CATHODE CURRENT vs. CATHODE VOLTAGE
4. OFF-STATE CATHODE CURRENT vs. FREE-AIR TEMPERATURE
5. RATIO OF DELTA REFERENCE VOLTAGE TO DELTA CATHODE VOLTAGE vs. FREE-AIR TEMPERATURE
6. EQUIVALENT INPUT NOISE VOLTAGE vs. FREQUENCY

#### FIGURE INDEX

##### Application Information

###### FIGURE #

7. COMPARISON OF REFERENCE RESISTOR VALUES BETWEEN AN LX6431B AND A TL1431. Resistors used with the LX6431B are 5 times higher in value.
8. COMPARISON OF REFERENCE RESISTOR VALUES BETWEEN AN LX6431B AND A TL1431. When used as 0.5%, 5V shunt regulators.

##### Parameter Measurement Information

###### FIGURE #

9. TEST CIRCUIT FOR  $V_{KA} = V_{REF}$
10. TEST CIRCUIT FOR  $V_{KA} > V_{REF}$
11. TEST CIRCUIT FOR  $I_{OFF}$

##### Typical Characteristics

###### FIGURE #

12. EQUIVALENT INPUT NOISE VOLTAGE OVER A 10-SECOND PERIOD
13. SMALL-SIGNAL VOLTAGE AMPLIFICATION vs. FREQUENCY
14. REFERENCE IMPEDANCE vs. FREQUENCY
15. PULSE RESPONSE
16. DIFFERENTIAL VOLTAGE AMPLIFICATION vs. FREQUENCY



#### CHARACTERISTIC CURVES

**FIGURE 1.** — REFERENCE VOLTAGE vs. FREE-AIR TEMPERATURE

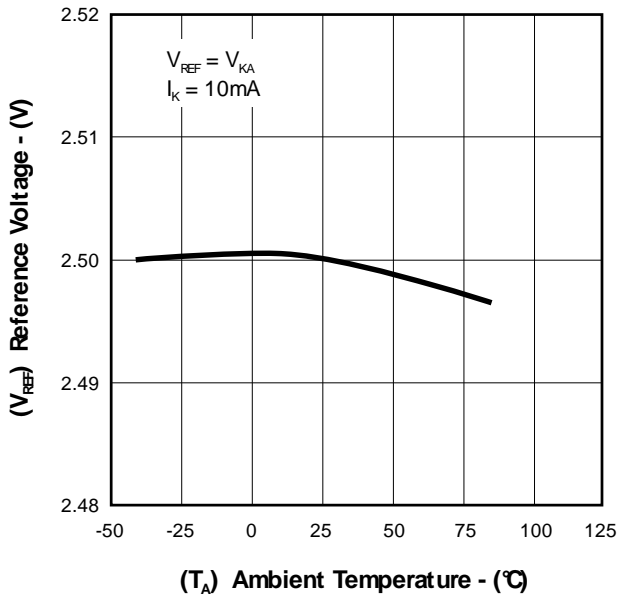

**FIGURE 2.** — REFERENCE CURRENT vs. FREE-AIR TEMPERATURE

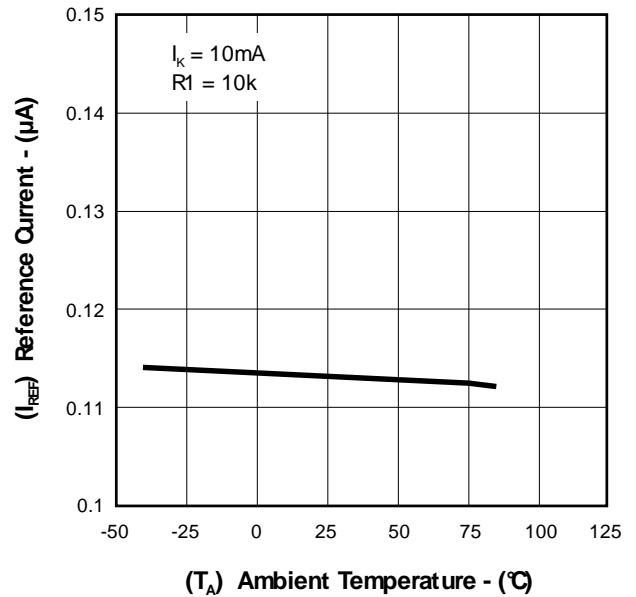

**FIGURE 3.** — CATHODE CURRENT vs. CATHODE VOLTAGE

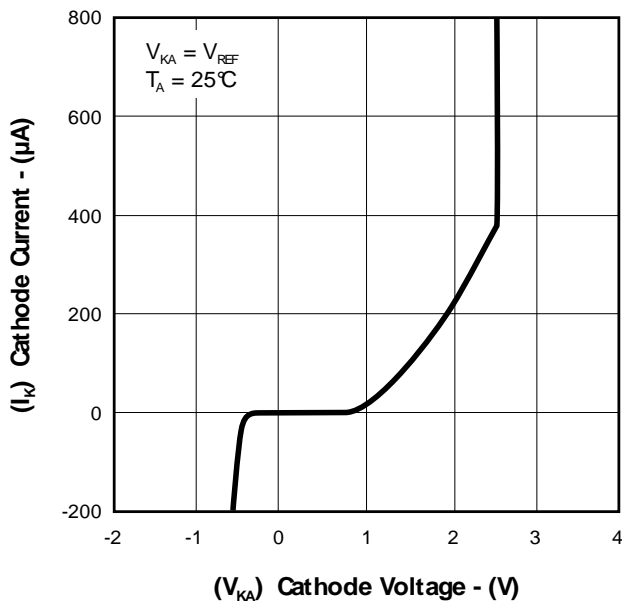

**FIGURE 4.** — OFF-STATE CATHODE CURRENT vs. FREE-AIR TEMPERATURE

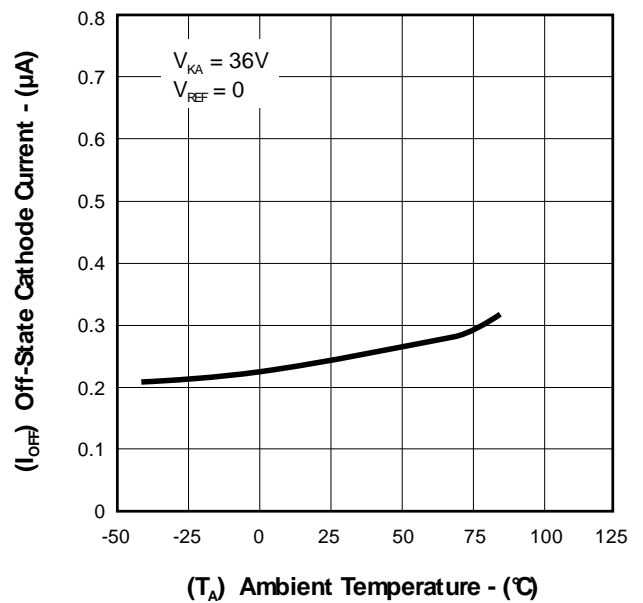

# LX6431/ LX6431A/ LX6431B

## PRECISION PROGRAMMABLE REFERENCES

### PRODUCTION DATA SHEET

#### CHARACTERISTIC CURVES

FIGURE 5. — RATIO OF DELTA REFERENCE VOLTAGE TO DELTA CATHODE VOLTAGE vs. FREE-AIR TEMPERATURE

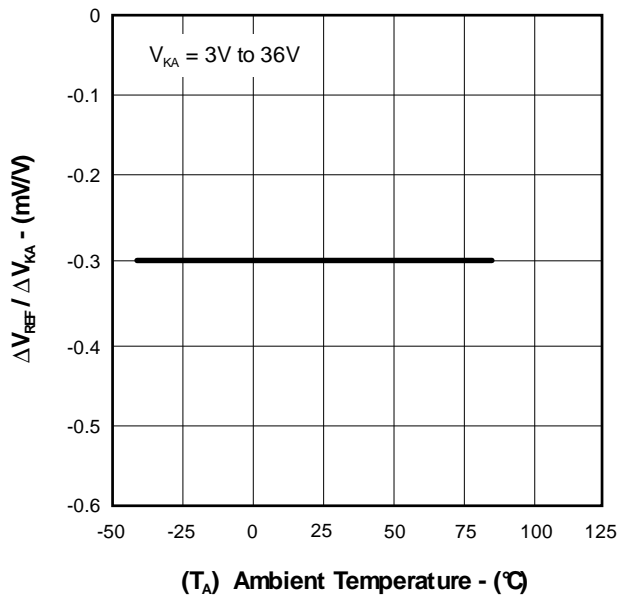
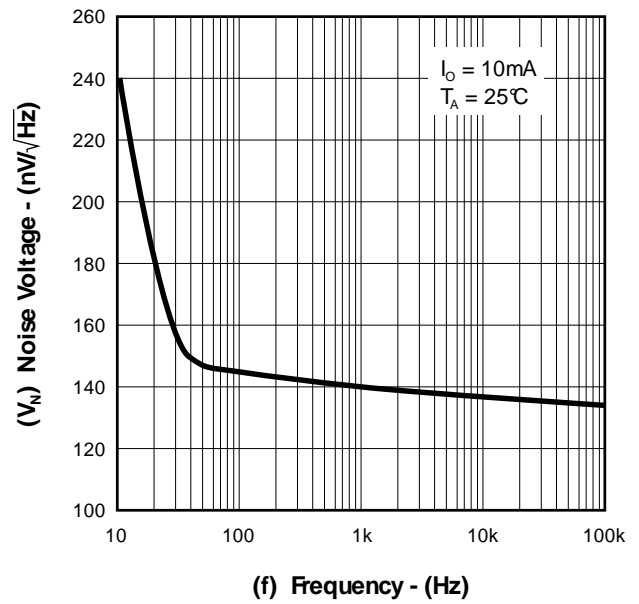

FIGURE 6. — EQUIVALENT INPUT NOISE VOLTAGE vs. FREQUENCY



#### APPLICATION INFORMATION

##### Application Hints

The reference input current of the LX6431 series voltage references is much lower than other similar precision parts. This helps to design programmable voltage references that can use much higher value programming resistors while maintaining the same accuracy as the other precision parts. Figure 7 below shows a 5V, 1% shunt regulator using the LX6431B and a shunt regulator using the TL1431 (Also available from Linfinity). Figure 8 shows 0.5% shunt regulators. Noteworthy are the values of the reference resistors used in the two circuits. With the LX6431B it is possible to use 25k resistors for setting the output voltage with 1% precision as opposed to 5k programming resistors when the same precision needs to be achieved with a TL1431.

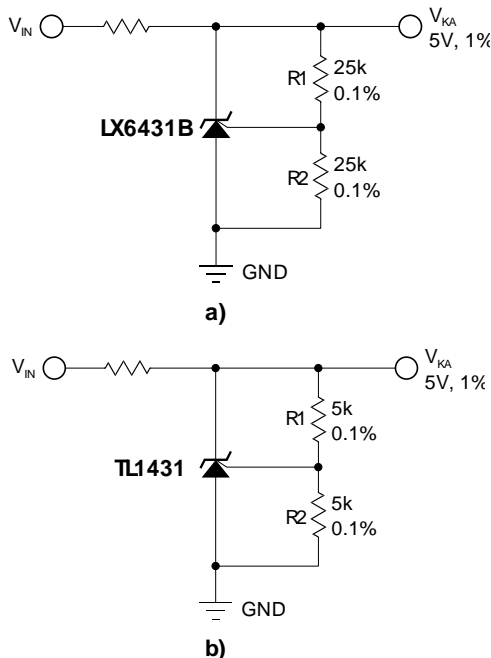

**FIGURE 7** — Comparison of reference resistor values between an LX6431B and a TL1431, resistors used with the LX6431B are 5 times higher in value.

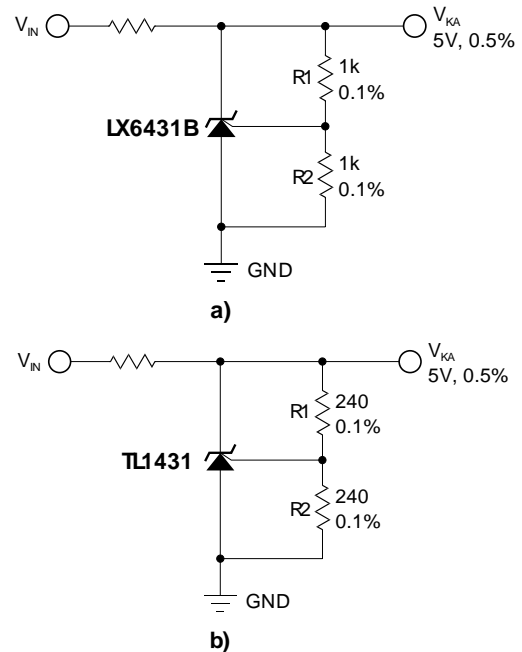

**FIGURE 8** — Comparison of reference resistor values between an LX6431B and a TL1431, when used as 0.5%, 5V shunt regulators.

The output voltage of the reference can be programmed by using the formula below:

$$V_{KA} \cong 2.5 * \left( 1 + \frac{R1}{R2} \right)$$

If more accuracy is required then the effects of the input bias current ( $I_{REF}$ ) must be taken into account. The formula below accounts for the error this current produces.

$$V_{KA} = 2.5 * \left( 1 + \frac{R1}{R2} \right) + I_{REF} * R1$$

Smaller values of programming resistors tend to minimize bias current errors. In this respect the low input current characteristics of the LX6431B helps to reduce the power dissipation on the programming resistors by a factor of five compared to other references like the TL1431 and TL431.

The LX6431 series of voltage references have an enhanced circuit design that can tolerate any value of cathode to anode capacitance.



#### PARAMETER MEASUREMENT INFORMATION

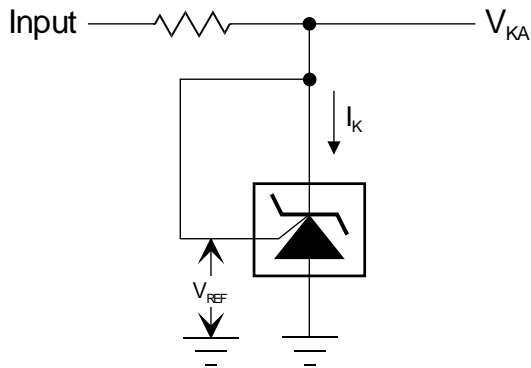

FIGURE 9 — TEST CIRCUIT FOR  $V_{KA} = V_{REF}$

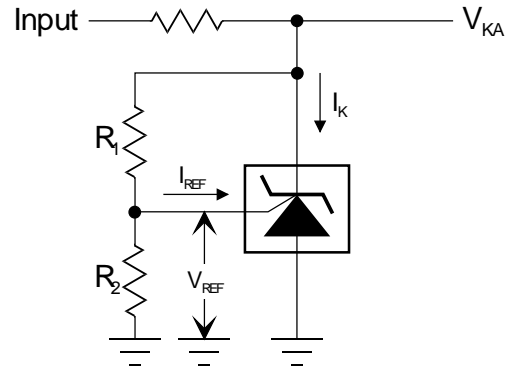

FIGURE 10 — TEST CIRCUIT FOR  $V_{KA} > V_{REF}$

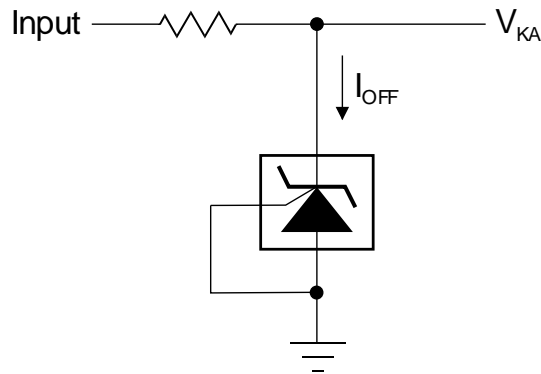

FIGURE 11 — TEST CIRCUIT FOR  $I_{OFF}$

# LX6431/ LX6431A/ LX6431B

## PRECISION PROGRAMMABLE REFERENCES

### PRODUCTION DATA SHEET

#### TYPICAL CHARACTERISTICS

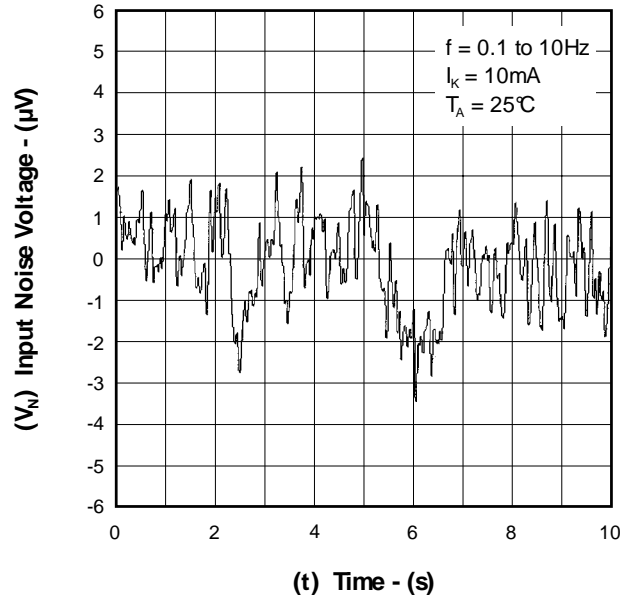
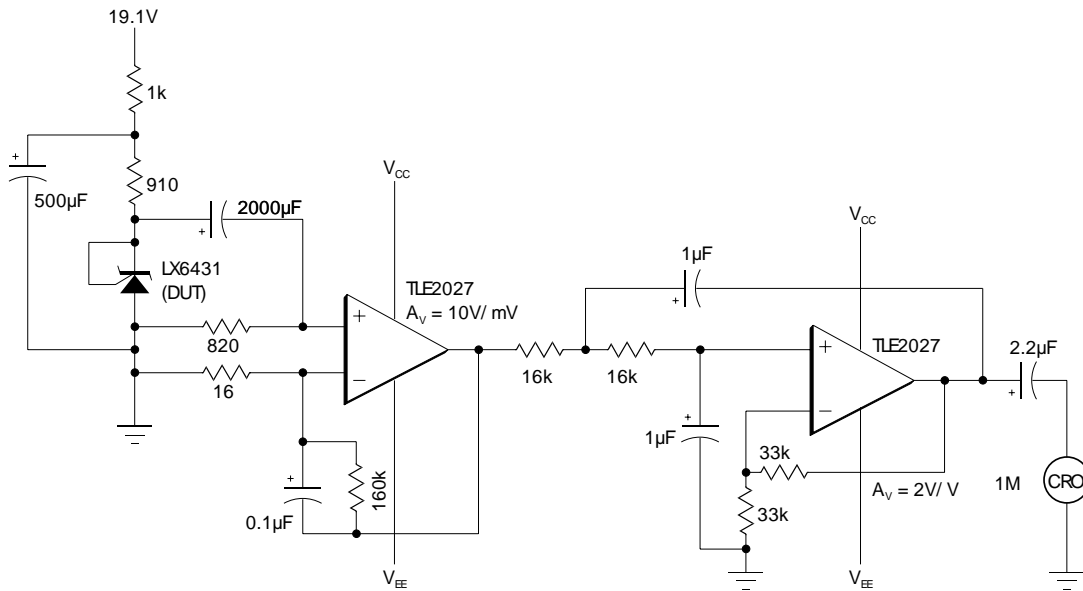

FIGURE 12. — EQUIVALENT INPUT NOISE VOLTAGE OVER A 10-SECOND PERIOD



Test Circuit for 0.1Hz to 10Hz Equivalent Input Noise Voltage



# LX6431/ LX6431A/ LX6431B

## PRECISION PROGRAMMABLE REFERENCES

### PRODUCTION DATA SHEET

#### TYPICAL CHARACTERISTICS

FIGURE 13. — SMALL-SIGNAL VOLTAGE AMPLIFICATION vs. FREQUENCY

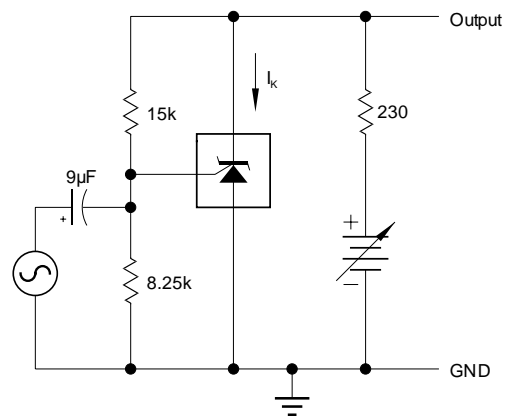
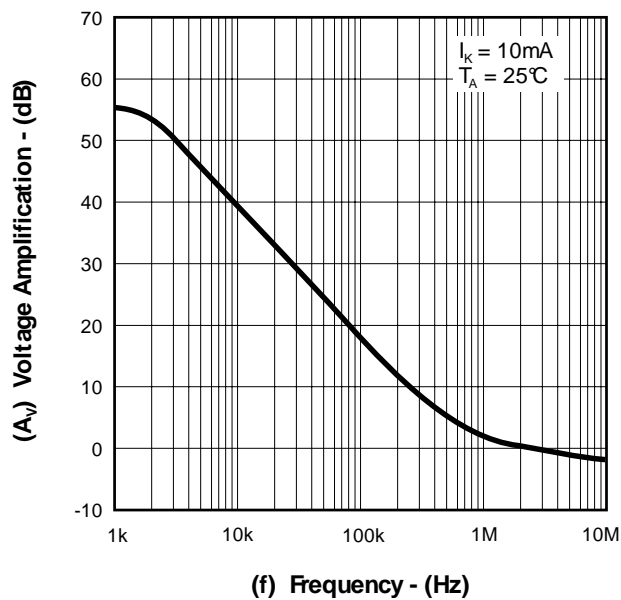

Test Circuit for Voltage Amplification

FIGURE 14. — REFERENCE IMPEDANCE vs. FREQUENCY

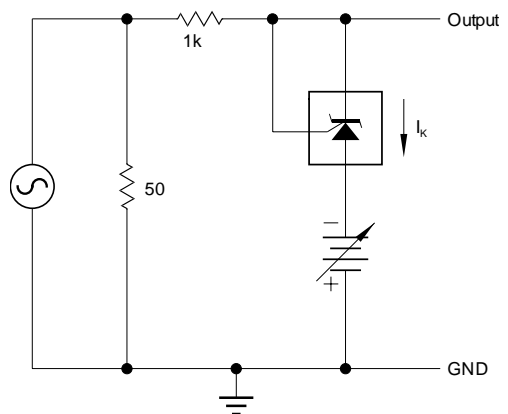
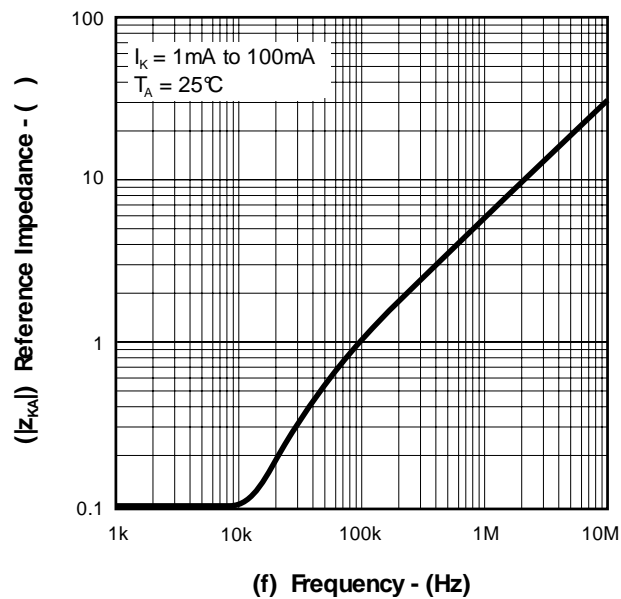

Test Circuit for Reference Impedance



#### TYPICAL CHARACTERISTICS

FIGURE 15. — PULSE RESPONSE

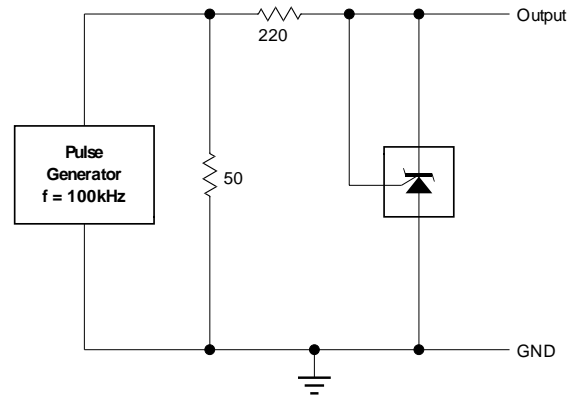
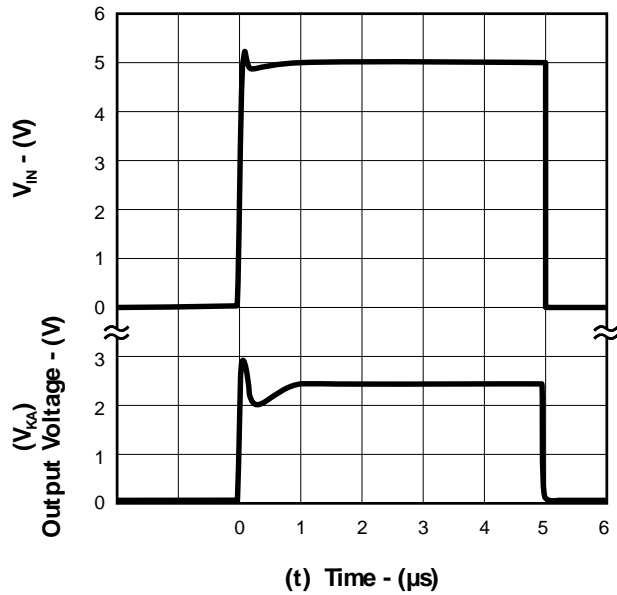

Test Circuit for Pulse Response

FIGURE 16. — DIFFERENTIAL VOLTAGE AMPLIFICATION vs. FREQUENCY

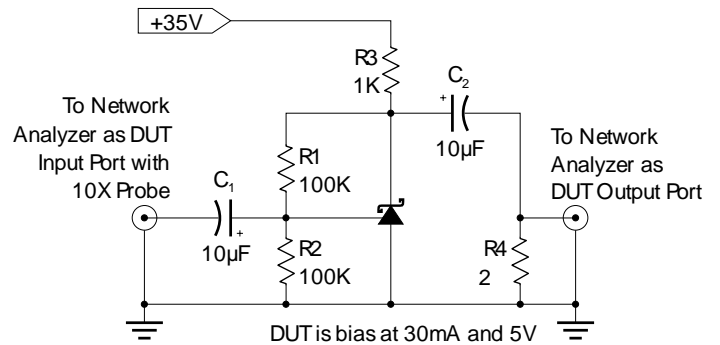
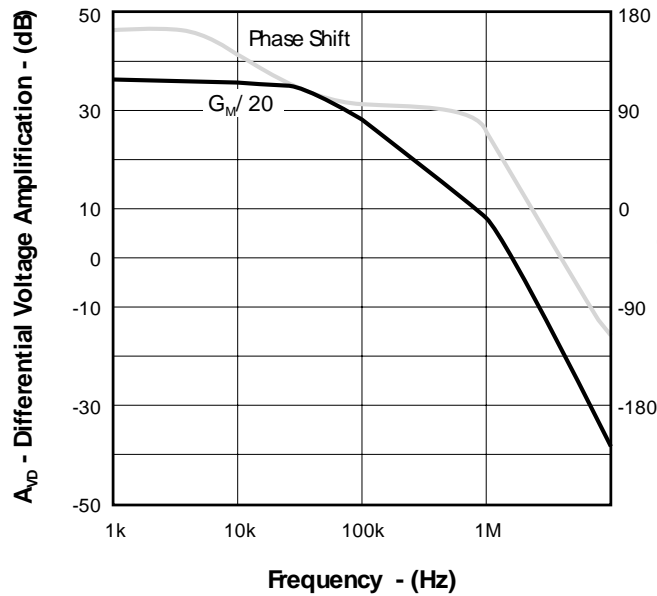

Test Setup for Measuring AVD vs. Frequency

