

DESCRIPTION

The Microsemi LX8942 is a dual 8.2V/5V positive voltage regulator. One output is a high current (up to 1000mA) regulator that can be turned on or off by a high impedance low current TTL compatible switch. The second or standby output remains on regardless. The on/off switch not only shuts off the high current output but actually puts the IC in a micropower mode, achieving low quiescent current. This unique characteristic coupled with an extremely low dropout, (0.55V for output current of 10mA) makes the LX8942 well suited for power systems that require standby memory. The LX8942 includes other features which were originally designed for automotive applications. These include protection from reverse battery installations, double battery jumps and load dump (transients).

The high current regulator has over voltage shutdown to protect both the internal circuitry and the load during line transients, such as load dump (60V). In addition, the high current regulator design also has built-in protection for short circuit and thermal overload. During these fault conditions of the primary output, the standby regulator will continue to power its load.

The LX8942 is the 8.2 volt, $\pm 5\%$ version of a family of dual regulators with a standby output voltage of 5V. Other high-current outputs programmed for 5V and 12V regulation are available in the SG29055, SG29125 devices. They are designed to function over the full automotive ambient temperature range of -40°C to 85°C .

IMPORTANT: For the most current data, consult MICROSEMI's website: <http://www.microsemi.com>

KEY FEATURES

- 2% Internally Trimmed Output
- Two regulated outputs
- Output current in excess of 1000mA
- Low quiescent current standby regulator
- Drop-out Voltage, Input-output differential $<0.6\text{V}$ at 0.5A
- Reverse battery protection
- 60V load dump protection
- -50V reverse transient protection
- Short circuit protection
- Internal thermal overload protection
- ON/OFF switch for high current output
- Surface Mount TO-252

APPLICATIONS

- Automotive electronics for controls, entertainment and safety functions
- Continuous operation systems

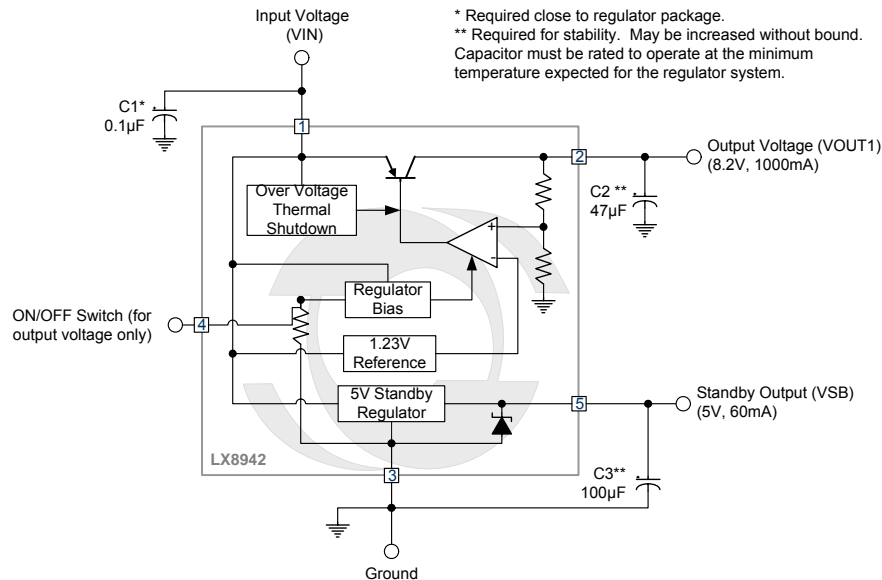
PRODUCT HIGHLIGHT

PACKAGE ORDER INFO

T_j ($^{\circ}\text{C}$)	DT	Plastic TO-252 5-Pin
		RoHS Compliant / Pb-free
-40 to 85		LX8942IDT

Note: Available in Tape & Reel. Append the letters "TR" to the part number. (i.e. LX8942IDT-TR)

ABSOLUTE MAXIMUM RATINGS

Input Voltage (V_{IN}) Operating	26V
Input Voltage (V_{IN}) Over Voltage Transient.....	-15V to 60V
ON/OFF Switch	-0.3V to V_{IN}
Operating Ambient Temperature Range	-40°C to +85°C
Storage Temperature Range (T_{STG}).....	-65°C to 150°C
Maximum Operating Junction Temperature (T_J)	150°C

Note: Exceeding these ratings could cause damage to the device. All voltages are with respect to Ground. Currents are positive into, negative out of specified terminal.

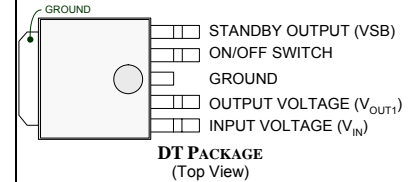
PACKAGE PIN OUT

RoHS / Pb-free 100% matte Tin Lead Finish

Note: The heat sink tab is the Ground Connection for this package.

THERMAL DATA
DT Plastic TO-252 5-Pin

THERMAL RESISTANCE-JUNCTION TO CASE, θ_{JC}	9°C/W
THERMAL RESISTANCE-JUNCTION TO AMBIENT, θ_{JA}	80°C/W

Junction Temperature Calculation: $T_J = T_A + (P_D \times \theta_{JA})$.

The θ_{JA} numbers are guidelines for the thermal performance of the device/pc-board system. All of the above assume no ambient airflow.

FUNCTIONAL PIN DESCRIPTION

Name	Description
V_{IN}	Input Voltage Supply.
V_{OUT1}	+8.2V Output Voltage at up to 1000mA.
GND	Regulator Ground.
ON/OFF	TTL Logic level input control for turning ON and OFF the high current V_{OUT1} regulator.
V_{SB}	+5V Standby Output Voltage at up to 60mA.

RECOMMENDED OPERATING CONDITIONS

Range over which the device is functional.

Parameter	Symbol	LX8942			Units
		Min	Typ	Max	
Input Voltage	V_{IN}	9		26	V
ON/OFF Threshold Voltage Low Level, (V_{OUT1} is OFF)	V_{IL}			0.8	V
ON/OFF Threshold Voltage High level, (V_{OUT1} is ON)	V_{IH}	2			V
Load Current V_{OUT1} (with adequate heatsinking)		5		1000	mA
Maximum Line Transient (Load Dump) $V_{SB} < 6V$				60	V
Input Capacitor (V_{IN} to GND)		0.1			μF
Reverse Polarity D.C. Input Voltage (V_{IN}) ($V_{OUT1} > -0.6V$, 16 Ω Load)				-15	V
Reverse Polarity Transient Input Voltage (V_{IN}) (1% Duty Cycle, T < 100ms, $V_{OUT1} > -9V$, 16 Ω Load)				-50	V
Output Capacitor (V_{OUT1} to GND & V_{SB} to GND)		10			μF
Output Capacitor ESR Value		0.5		5.0	Ω

ELECTRICAL CHARACTERISTICS

Unless otherwise specified, the following specifications apply over the operating ambient temperature $0^{\circ}\text{C} \leq T_A \leq 70^{\circ}\text{C}$ except where otherwise noted and the following test conditions: $T_A = 25^{\circ}\text{C}$, $V_{IN} = 14\text{V}$, $I_{O1} = 50\text{mA}$ for V_{OUT1} and 10mA for V_{SB} and are for DC characteristics only. Low duty cycle pulse testing techniques are used which maintains junction and case temperatures equal to the ambient temperature.

Parameter	Symbol	Test Conditions	LX8942			Units
			Min	Typ	Max	
VOLTAGE OUTPUT (V_{OUT1}) SECTION						
Output Voltage (NOTE 1)	V_{OUT1}	$9\text{V} < V_{IN} < 26\text{V}$, $I_{O1} < 1000\text{mA}$	7.6	8.0	8.4	V
Line Regulation		$9\text{V} < V_{IN} < 16\text{V}$, $I_{O1} = 5\text{mA}$		4	25	mV
		$9\text{V} < V_{IN} < 26\text{V}$, $I_{O1} = 5\text{mA}$		10	50	mV
Load Regulation		$5\text{mA} < I_{O1} < 1000\text{mA}$		10	50	mV
Output Impedance		500mA_{DC} and 10mA_{RMS} , $100\text{Hz} - 10\text{kHz}$		200		$\text{m}\Omega$
Quiescent Current		$I_{O1} < 10\text{mA}$, No Load on Standby		2		mA
		$I_{O1} = 500\text{mA}$, No Load on Standby		40	100	mA
		$I_{O1} = 750\text{mA}$, No Load on Standby		90		mA
Output Noise Voltage		$10\text{Hz} - 100\text{kHz}$		100		μV_{RMS}
Long Term Stability				20		$\text{mV} / 1000\text{hr}$
Ripple Rejection		$F_{O1} = 120\text{Hz}$		66		dB
Dropout Voltage		$I_{O1} = 500\text{mA}$		0.45	0.60	V
		$I_{O1} = 1000\text{mA}$		0.7	1.2	V
Current Limit			1.0	1.8		A
Maximum Operational Input Voltage	V_{IN}	Double Battery	26.5	31		V
Maximum Line Transient	V_{IN}	$V_{O1} < 9\text{V}$	60	70		V
ON / OFF Switch	I_{IH}	$I_{O1} = 10\text{mA}$, Pin 4 = 2.4V			10	μA
ON / OFF Switch	I_{IL}	$I_{O1} = 10\text{mA}$, Pin 4 = 0.4V	-10			μA
STANDBY OUTPUT (V_{SB}) SECTION						
Output Voltage (Note 1)	V_{SB}	$6\text{V} < V_{IN} < 26\text{V}$, $I_{SB} < 60\text{mA}$	4.75	5.0	5.25	V
Line Regulation		$6\text{V} < V_{IN} < 26\text{V}$		4	50	mV
Load Regulation		$1\text{mA} < I_{SB} < 35\text{mA}$		10	25	mV
		$1\text{mA} < I_{SB} < 60\text{mA}$		25	50	mV
Output Impedance		1mA_{DC} and 1mA_{RMS} , $100\text{Hz} - 10\text{kHz}$		1		Ω
Quiescent Current		$I_{SB} < 10\text{mA}$, V_{OUT1} OFF		1.2	3	mA
Output Noise Voltage		$10\text{Hz} - 100\text{kHz}$		300		μV_{RMS}
Long Term Stability				20		$\text{mV} / 1000\text{hr}$
Ripple Rejection		$F_{SB} = 120\text{Hz}$		66		dB
Dropout Voltage		$I_{SB} < 60\text{mA}$		0.55	0.70	V
Current Limit			60	100		mA
Maximum Line Transient	V_{IN}	$4.75\text{V} < V_{SB} < 6\text{V}$	60	70		V

Note 1: The Temperature Extremes are Guaranteed but not 100% Production Tested.

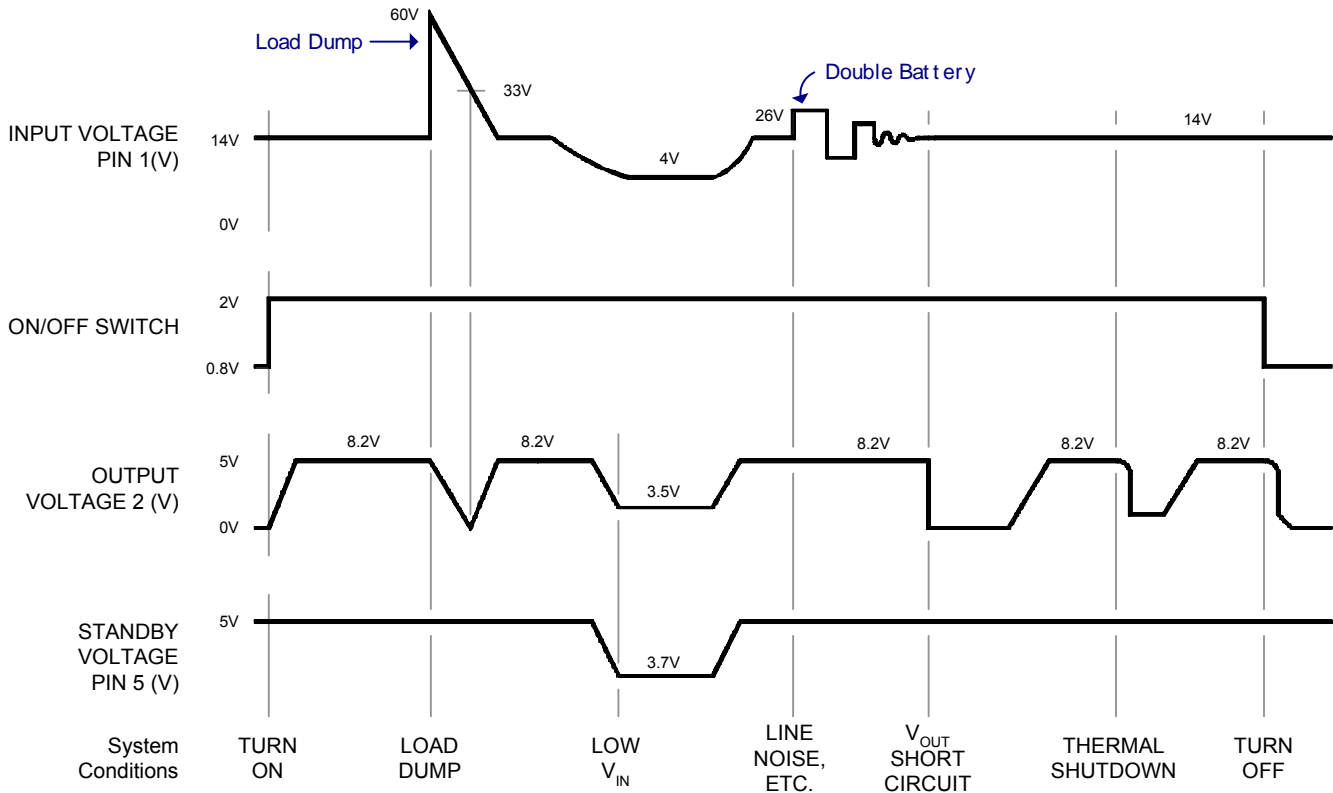
TYPICAL CIRCUIT WAVEFORMS

APPLICATION NOTE

The advantages of using a low-dropout regulator such as the LX8942 are the need for less “headroom” for full regulation, and the inherent reverse polarity protection provided by the PNP output device. A typical NPN regulator design requires an input to output differential of approximately two volts minimum. This is due to the $2V_{be} + V_{cesat}$ of the NPN Darlington used in the output, coupled with the voltage drop across the current limit resistor. In contrast, the “PNP Regulator” uses a single series pass transistor with its single V_{cesat} , thus the lower input to output voltage differential or dropout voltage.

In addition to a low dropout voltage, an important advantage of the LX8942 series is low quiescent current in the standby mode. When the high current or primary regulator is shut off, the regulator enters a micropower mode. Here all but the most essential circuitry to power the standby output is deactivated. This allows the lowest possible quiescent current (typical around 1.2mA), a vital factor when used in a battery powered system.

In some applications the regulator output voltage is used not only as a power supply but also as a voltage reference for control systems. In such cases not just the temperature stability of the output is important but also the initial accuracy. The LX8942 fills this need as the internal bandgap reference is trimmed allowing a typical output voltage tolerance of $\pm 1\%$.

EXTERNAL CAPACITORS

To stabilize the outputs and prevent oscillation (perhaps by many volts) external capacitors are required. The minimum recommended value for the output capacitors is $47\mu\text{F}$ for the 8.2V output and $100\mu\text{F}$ for the 5V output. The actual size and type will likely vary according to the particular application, e.g., operating temperature range and load. Another consideration is the effective series resistance (ESR) of the capacitor. Capacitor ESR will vary by manufacturer. Consequently, some evaluation may be required to determine the minimum value of the output capacitors. Generally worst case occurs at the maximum load and minimum ambient temperature.

The size of the output capacitor can be increased to any value above the minimum. One possible advantage of this would be to maintain the output voltage during brief periods of negative input transients.

The output capacitors chosen should be rated for the full range of ambient temperature over which the circuit will be exposed and expected to operate. For example, many aluminum type electrolytic capacitors will freeze at -30°C . The effective capacitance is reduced to zero in such a situation. Capacitors rated for -40°C operation must be used in order to maintain regulator stability at that temperature. Tantalum capacitors satisfy this requirement.

STANDBY OUTPUT

The LX8942 differs from most fixed voltage regulators in that it is equipped with two regulator outputs instead of one. The additional output is intended for use in systems requiring standby memory circuits. While the high current regulator output can be controlled with the ON/OFF pin described below, the standby remains on under all conditions as long as sufficient input voltage is applied to the IC. Thus, memory and other circuits powered by this output remain unaffected by positive line transients, thermal shutdown, etc.

The standby regulator circuit is designed so that the quiescent current to the IC is very low ($<1.5\text{mA}$) when the other regulator output is off.

If the standby output is not required it can be disabled. This is accomplished by connecting a resistor from the standby output to the supply voltage, thereby also eliminating the requirement for a more expensive output capacitor to prevent unwanted oscillations. The resistor value depends upon the minimum input voltage expected for a given system. Since the standby output is shunted with an internal 5.6V zener, the current through the external resistor should be sufficient to bias internal resistors up to this point. Approximately 60mA will suffice, resulting in a 10k external resistor for most applications (Figure 1).

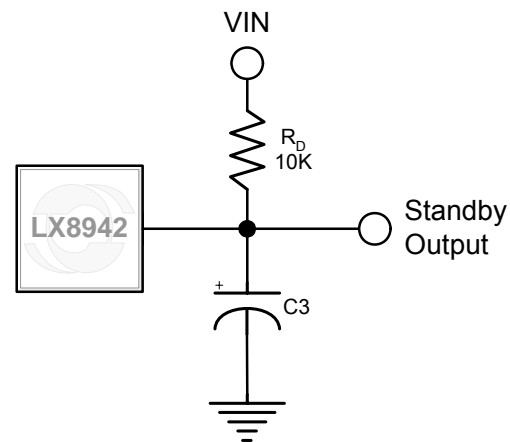

Figure 1 – Disabling Standby Output to Eliminate C3



LX8942

Low Dropout Dual Regulator

PRODUCTION DATA SHEET

APPLICATION NOTE

The high current regulated output features fault protection against over voltage as well as a thermal shutdown feature. If the input voltage rises above 33V (load dump), the high current output shuts down automatically. The internal circuitry is thus protected and the IC is able to survive higher voltage transients than might otherwise be expected. The thermal shutdown of the high current output effectively guards against overheating of the die since this section of the IC is the principle source of power dissipation on the chip.

ON/OFF SWITCH

The ON/OFF pin is a high impedance low current switch that controls the main output voltage (pin 2). This is directly compatible with all 5 volt logic families. For use with open collector logic outputs, a 100Kresistor from this pin to a 5V supply, such as Pin 5, is required.

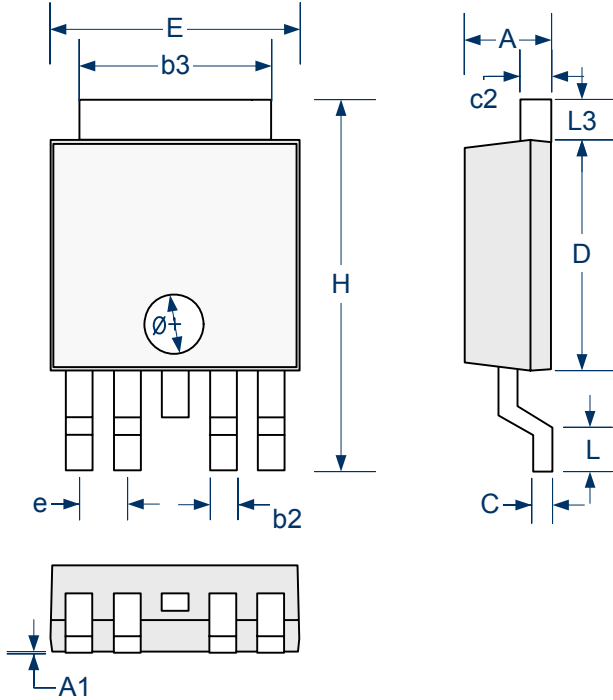
PACKAGE DIMENSIONS
DT 5-Pin Plastic TO-252

Dim	MILLIMETERS		INCHES	
	MIN	MAX	MIN	MAX
A	2.18	2.39	0.086	0.094
A1	0	0.23	0	0.009
b2	0.62	0.78	0.024	0.031
b3	5.00	5.46	0.197	0.215
C	0.45	0.61	0.018	0.024
c2	0.46	0.89	0.018	0.035
D	5.96	6.22	0.235	0.245
E	6.35	6.73	0.250	0.265
e	1.27 BSC		0.050 BSC	
H	9.40	10.41	0.370	0.410
L	1.08	1.40	0.043	0.055
L3	0.89	1.27	0.035	0.050
Ø	0.85	1.62	0.033	0.064

Note:

1. Dimensions do not include mold flash or protrusions; these shall not exceed 0.155mm(.006") on any side. Lead dimension shall not include solder coverage.



Microsemi[®]

LX8942

Low Dropout Dual Regulator

PRODUCTION DATA SHEET

NOTES

PRODUCTION DATA – Information contained in this document is proprietary to Microsemi and is current as of publication date. This document may not be modified in any way without the express written consent of Microsemi. Product processing does not necessarily include testing of all parameters. Microsemi reserves the right to change the configuration and performance of the product and to discontinue product at any time.