

## Linear MOSFET Power Module

$V_{DSS} = 600V$   
 $R_{DSon} = 125m\Omega \text{ typ @ } T_j = 25^\circ C$   
 $I_D = 45A^* @ T_c = 25^\circ C$

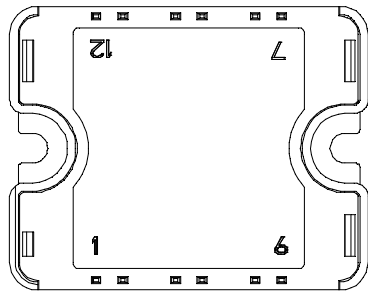
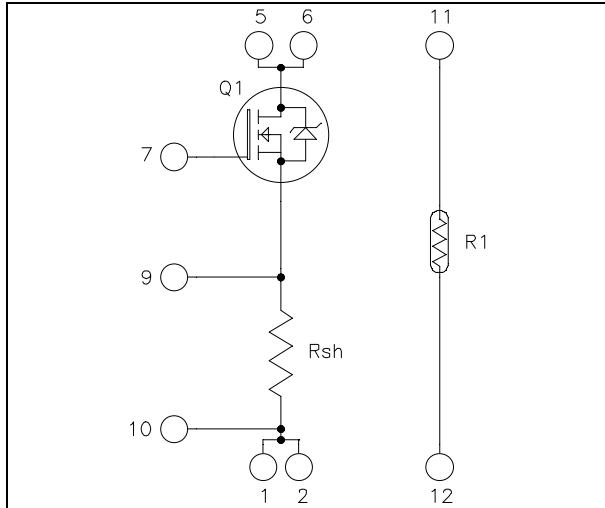

Pins 1/2 ; 5/6 must be shorted together

### Application

- Electronic load dedicated to power supplies and battery discharge testing

### Features

- Linear MOSFET
- Very low stray inductance
- Internal thermistor for temperature monitoring
- High level of integration
- AlN substrate for improved thermal performance

### Benefits

- Direct mounting to heatsink (isolated package)
- easy series and parallels combinations for power and voltage improvements
- Low junction to case thermal resistance
- Solderable terminals both for power and signal for easy PCB mounting
- Low profile
- RoHS Compliant

### Absolute maximum ratings

Symbol	Parameter	Max ratings	Unit
$V_{DSS}$	Drain - Source Breakdown Voltage	600	V
$I_D$	Continuous Drain Current	$T_c = 25^\circ C$	45*
		$T_c = 80^\circ C$	33*
$I_{DM}$	Pulsed Drain current	172	
$V_{GS}$	Gate - Source Voltage	$\pm 30$	V
$R_{DSon}$	Drain - Source ON Resistance	150	m $\Omega$
$P_D$	Maximum Power Dissipation ❶	$T_c = 25^\circ C$	568
$I_{AR}$	Avalanche current (repetitive and non repetitive)	45	A
$E_{AR}$	Repetitive Avalanche Energy	50	mJ
$E_{AS}$	Single Pulse Avalanche Energy	3000	

\* Output current must be limited to 31A @  $T_c=25^\circ C$  and 22A @  $T_c=80^\circ C$  to not exceed the shunt specification.

❶ In saturation mode

**CAUTION:** These Devices are sensitive to Electrostatic Discharge. Proper Handling Procedures Should Be Followed. See application note APT0502 on [www.microsemi.com](http://www.microsemi.com)

All ratings @  $T_j = 25^\circ\text{C}$  unless otherwise specified

### Electrical Characteristics

Symbol	Characteristic	Test Conditions	Min	Typ	Max	Unit
$I_{DSS}$	Zero Gate Voltage Drain Current	$V_{DS} = 600\text{V}; V_{GS} = 0\text{V}$			25	$\mu\text{A}$
		$T_j = 25^\circ\text{C}$				
$R_{DS(on)}$	Drain – Source on Resistance	$V_{GS} = 10\text{V}, I_D = 22.5\text{A}$		125	150	$\text{m}\Omega$
		$T_j = 125^\circ\text{C}$				
$V_{GS(th)}$	Gate Threshold Voltage	$V_{GS} = V_{DS}, I_D = 2.5\text{mA}$	2		4	V
$I_{GSS}$	Gate – Source Leakage Current	$V_{GS} = \pm 30\text{V}$			$\pm 100$	nA

### Dynamic Characteristics

Symbol	Characteristic	Test Conditions	Min	Typ	Max	Unit
$C_{iss}$	Input Capacitance	$V_{GS} = 0\text{V}$		7600		$\text{pF}$
$C_{oss}$	Output Capacitance	$V_{DS} = 25\text{V}$		1280		
$C_{rss}$	Reverse Transfer Capacitance	$f = 1\text{MHz}$		620		

### Shunt Electrical Characteristics

Symbol	Characteristic	Min	Typ	Max	Unit
$R_{sh}$	Resistance value		20		$\text{m}\Omega$
$T_{sh}$	Tolerance		2		%
$P_{sh}$	Load capacity	$T_C = 25^\circ\text{C}$		20	W
		$T_C = 80^\circ\text{C}$		10	
$I_{sh}$	Current capacity	$T_C = 25^\circ\text{C}$		31	A
		$T_C = 80^\circ\text{C}$		22	

### Temperature sensor PTC

Symbol	Characteristic	Min	Typ	Max	Unit
$R_{25}$	Resistance @ $25^\circ\text{C}$	1980		2020	$\Omega$
$R_{100}/R_{25}$	Resistance ratio	$T_{amb} = 100^\circ\text{C} \& 25^\circ\text{C}$	1.676	1.696	1.716
$R_{-55}/R_{25}$	Resistance ratio	$T_{amb} = -55^\circ\text{C} \& 25^\circ\text{C}$	0.48	0.49	0.50
B	Temperature coefficient		7900		ppm/K

### Thermal and package characteristics

Symbol	Characteristic	Min	Typ	Max	Unit	
$R_{thJC}$	Junction to Case Thermal Resistance	MOSFET		0.22	$^\circ\text{C}/\text{W}$	
$V_{ISOL}$	RMS Isolation Voltage, any terminal to case $t = 1\text{ min}$ , $I_{isol} < 1\text{mA}$ , 50/60Hz	4000			V	
$T_j$	Operating junction temperature range	-40		150	$^\circ\text{C}$	
$T_{STG}$	Storage Temperature Range	-40		125		
$T_C$	Operating Case Temperature	-40		100		
Torque	Mounting torque	To heatsink	M4	2.5	4.7	N.m
Wt	Package Weight			80	g	

## SP1 Package outline (dimensions in mm)

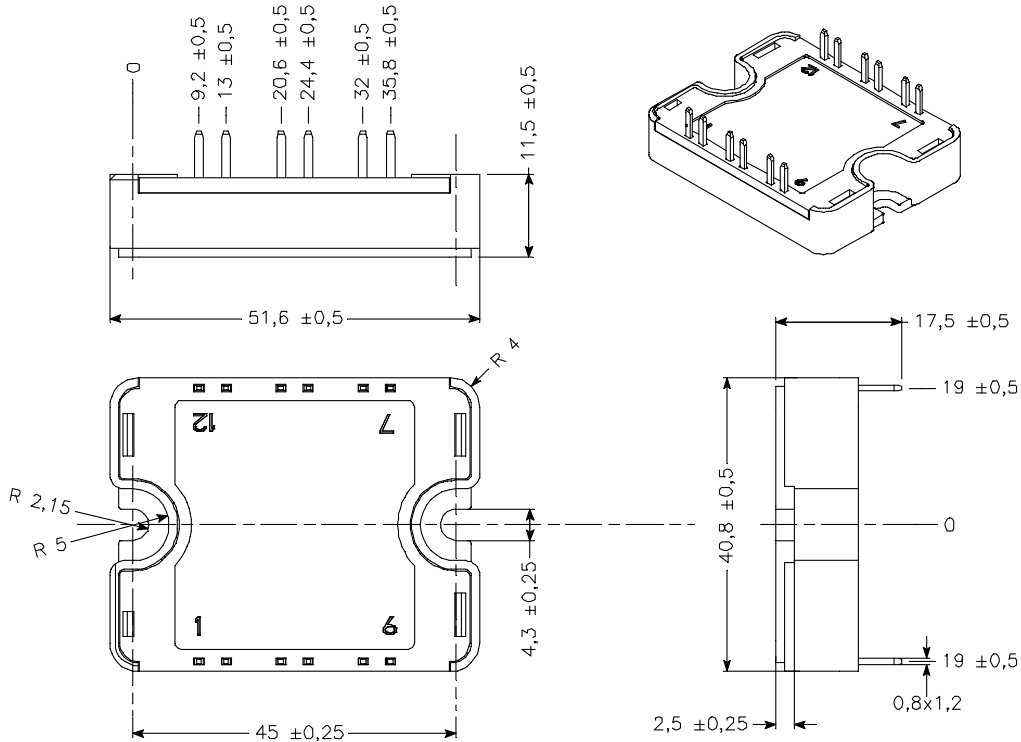

See application note 1904 - Mounting Instructions for SP1 Power Modules on [www.microsemi.com](http://www.microsemi.com)

## Typical Performance Curve (linear mode)

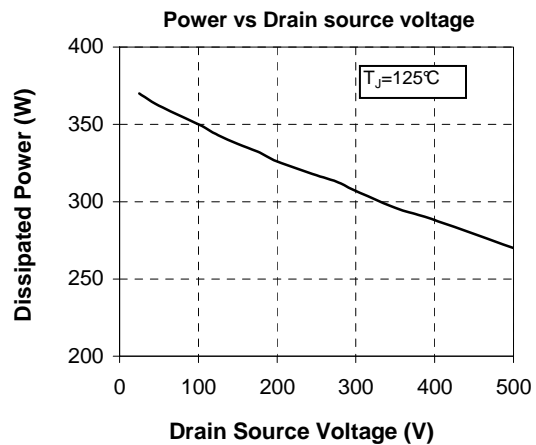
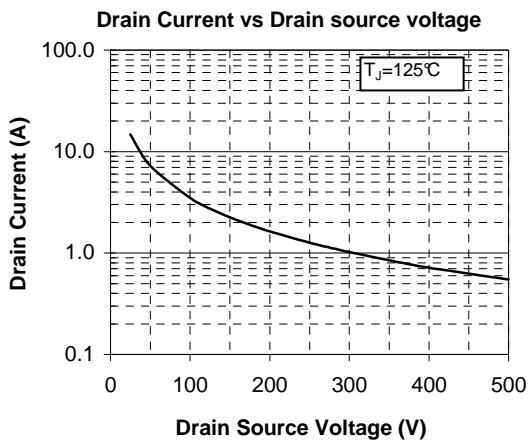

Microsemi reserves the right to change, without notice, the specifications and information contained herein

Microsemi's products are covered by one or more of U.S. patents 4,895,810 5,045,903 5,089,434 5,182,234 5,019,522 5,262,336 6,503,786 5,256,583 4,748,103 5,283,202 5,231,474 5,434,095 5,528,058 6,939,743 7,352,045 5,283,201 5,801,417 5,648,283 7,196,634 6,664,594 7,157,886 6,939,743 7,342,262 and foreign patents. U.S. and Foreign patents pending. All Rights Reserved.