

DESCRIPTION

The LX5501B is a low cost, broadband RFIC amplifier that has been manufactured with an InGaP/GaAs Heterojunction Bipolar Transistor (HBT) process (MOCVD).

Designed as an easily cascadable 50-ohm internally matched gain block, the LX5501B can be used for IF and RF amplification in wireless / wired voice and data communication products and broadband test equipment operating up to 6 GHz.

The amplifier is available in a plastic 5-lead SOT-23 package.

KEY FEATURES

- Advanced InGaP HBT
- DC to 6 GHz Operation
- Single Supply
- Low Idle Current (10 - 35 mA)
- Small Signal Gain ~ 9 dB at 6 GHz
- P1dB ~ 8 dBm at 6 GHz
- SOT-23 Package

APPLICATIONS

- PA driver for WLAN and Cordless Phones
- VCO buffer
- Low Current, High Gain Cascaded Amplifiers

PRODUCT HIGHLIGHT

- Input and output matched to 50 ohms for ease of cascading.
- Cascaded gain blocks can be individually biased for the lowest supply current.

PACKAGE ORDER INFO

	SE Plastic SOT-23 5 pin
	RoHS Compliant / Pb-free Transition DC: 0503
-40 to +85°C	LX5501BSE

Note: Available in Tape & Reel. Append the letters "TR" to the part number. (i.e. LX5501BSE-TR)

ABSOLUTE MAXIMUM RATINGS

DC Supply Voltage	6V
Collector Current	100mA
RF Input Power	10dBm
Operating Temperature Range	-40 to +85°C
Storage Temperature Range	-65°C to 150°C
Peak Package Solder Reflow Temp. (40 seconds max. exposure) ..	260°C (+0, -5)

Note: Exceeding these ratings could cause damage to the device. All voltages are with respect to Ground. Currents are positive into, negative out of specified terminal.

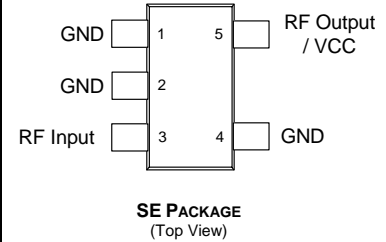
PACKAGE PIN OUT

RoHS / Pb-free 100% Matte Tin Lead Finish

THERMAL DATA
SE Plastic SOT-23 5-Pin

THERMAL RESISTANCE-JUNCTION TO CASE, θ_{JC}	138°C/W
THERMAL RESISTANCE-JUNCTION TO AMBIENT, θ_{JA}	245°C/W

Junction Temperature Calculation: $T_J = T_A + (P_D \times \theta_{JA})$.

The θ_{JA} numbers are guidelines for the thermal performance of the device/pc-board system. All of the above assume no ambient airflow.

FUNCTIONAL PIN DESCRIPTION

Pin No.	Description
1	Ground
2	Ground
3	RF Input
4	Ground
5	RF Output/VCC Supply

RECOMMENDED OPERATING CONDITIONS

Parameter	Symbol	LX5501B			Units
		Min	Typ	Max	
Supply Voltage (with appropriate external resistor)	VCC	2.7		6	V
Quiescent Current (No RF input)	Icq	10		40	mA

ELECTRICAL CHARACTERISTICS

Conditions: +25°C

Parameter	Symbol	Test Conditions	LX5501B			Units
			Min	Typ	Max	
GENERAL SPECIFICATIONS (FIG 1. TEST CIRCUIT)						
Small Signal Gain	S21	Frequency = 6 GHz		9		dB
P1dB Compression	P1dB	Frequency = 6 GHz		8		dBm
Input Return Loss	S11	Frequency = 4.9-6 GHz		-10		dB
Output Return Loss	S22	Frequency = 4.9-6 GHz		-9		dB
Isolation	S12	Frequency = 4.9-6 GHz		-20		dB
Harmonics		Frequency = 6 GHz, Pout = P1dB		-30		dBc
Quiescent Current	Icq			23		mA

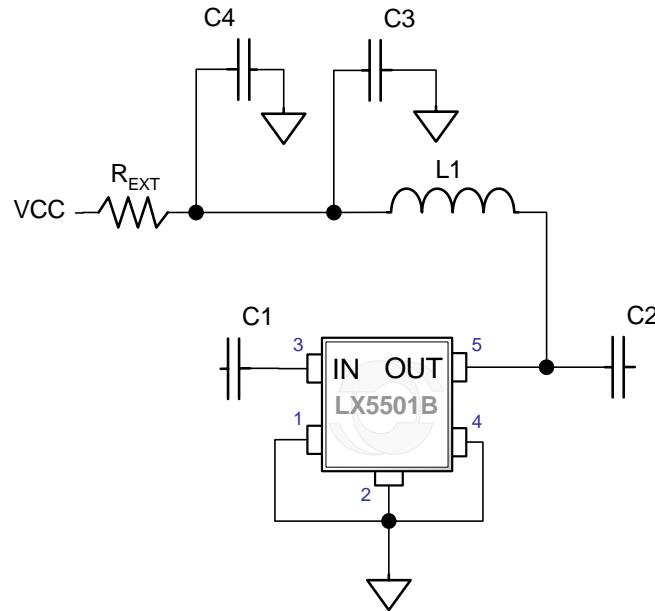
FIGURE 1: TEST CIRCUIT FOR 4 TO 6 GHz

Location	Value	Comment
C1,C2	2pF	DC block (0402)
C3	10pf	RF decoupling (0402)
C4	0.1μF	LF decoupling (0402)
L1	3.3nH	RF choke (0402)
R _{EXT}	5 ohms	Bias setting resistor (0402)
V _{cc}	2.85V	Supply Voltage

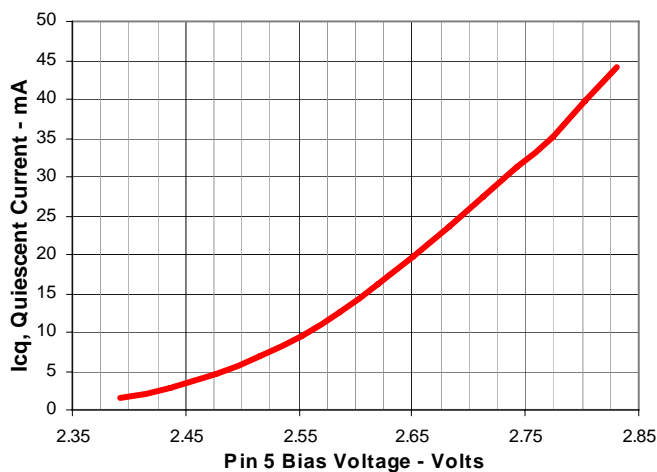
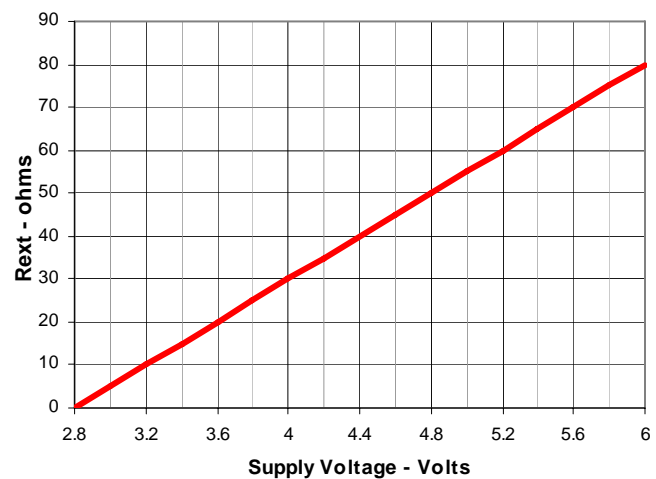
QUIESCENT CURRENT VS BIAS VOLTAGE

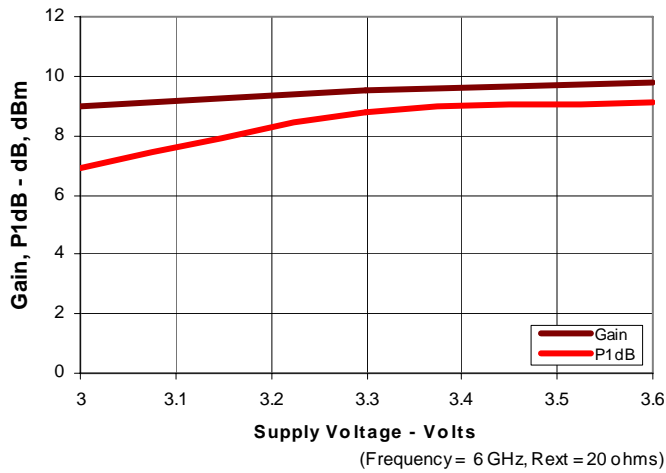
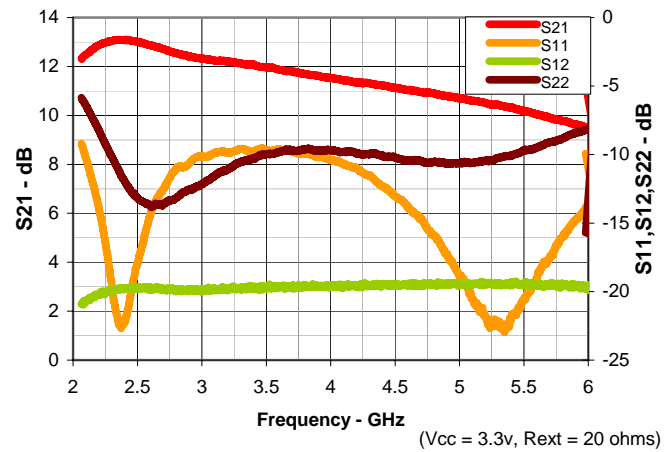
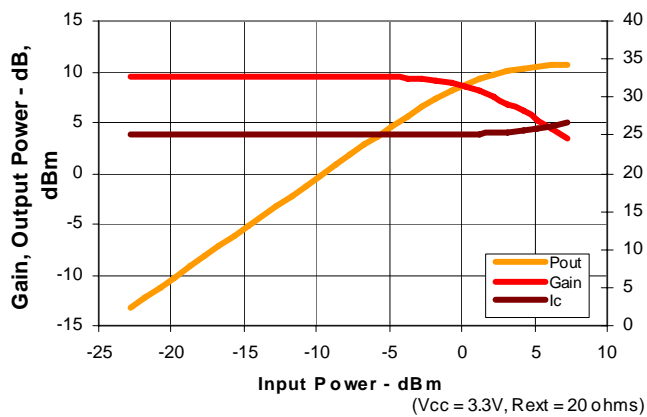
REXT VS SUPPLY VOLTAGE

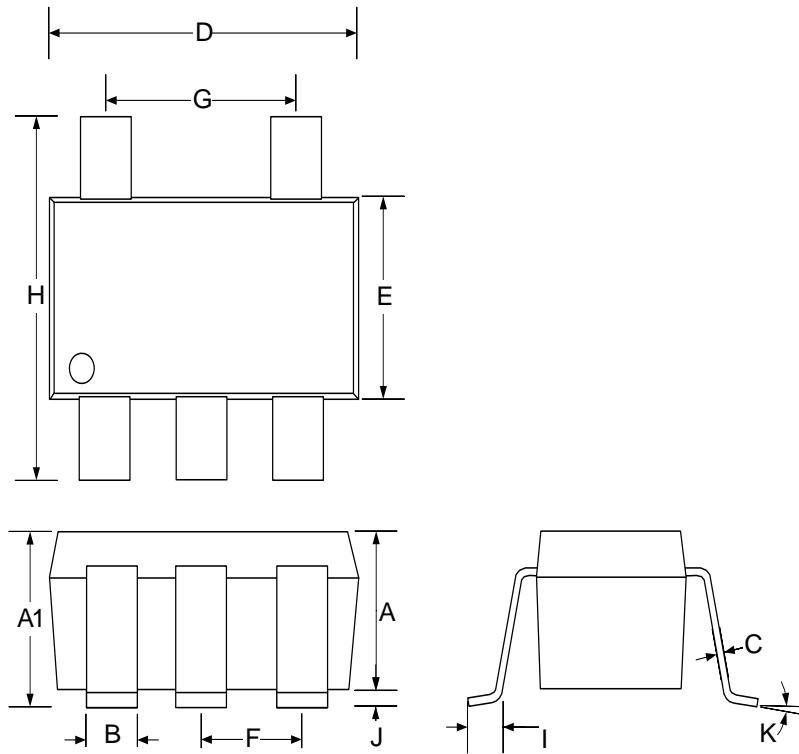
 Recommended R_{EXT} Value versus Maximum Supply Voltage

P1dB, GAIN VS VCC

S PARAMETER

5.8 GHz POWER SWEEP

PACKAGE DIMENSIONS
SE 5 Pin Plastic SOT-23

Dim	MILLIMETERS		INCHES	
	MIN	MAX	MIN	MAX
A	0.90	1.30	0.035	0.051
A1	0.90	1.45	0.035	0.057
B	0.25	0.50	0.010	0.020
C	0.09	0.20	0.004	0.008
D	2.80	3.10	0.110	0.122
E	1.50	1.75	0.059	0.069
F	0.95 BSC		0.038 BSC	
G	1.90 BSC		0.075 BSC	
H	2.60	3.00	0.102	0.118
I	0.35	0.55	0.014	0.022
J	0.00	0.15	0.000	0.006
K	10°MAX		10°MAX	

Note:

1. Dimensions do not include mold flash or protrusions; these shall not exceed 0.155mm(.006") on any side. Lead dimension shall not include solder coverage.



MicrosemiTM

LX5501B

InGAP HBT Gain Block

PRODUCTION DATA SHEET

NOTES

PRODUCTION DATA – Information contained in this document is proprietary to Microsemi and is current as of publication date. This document may not be modified in any way without the express written consent of Microsemi. Product processing does not necessarily include testing of all parameters. Microsemi reserves the right to change the configuration and performance of the product and to discontinue product at any time.