

DESCRIPTION

This general-purpose amplifier is a low cost, broadband RFIC manufactured with an InGaP/GaAs Hetero-junction Bipolar Transistor (HBT) process (MOCVD).

Designed as an easily cascadable 50-ohm internally matched gain block, the LX5501A can be used for IF and RF amplification in wireless / wired voice and data communication products as well as in broadband test equipment operating up to 6 GHz.

The amplifier is available in a plastic 5-lead SOT-23 package.

IMPORTANT: For the most current data, consult MICROSEMI's website: <http://www.microsemi.com>

KEY FEATURES

- Advanced InGaP HBT
- DC to 6 GHz Operation
- Single Supply
- Low Idle Current (10 - 35 mA)
- Small Signal Gain ~ 11 dB at 6 GHz
- P1dB ~ 11 dBm at 6 GHz
- SOT-23 Package

APPLICATIONS

- PA driver for WLAN and Cordless Phones.
- VCO buffer.
- Low Current, High Gain Cascaded Amplifiers.

PRODUCT HIGHLIGHT

- Fully characterized for 5v operation (with external bias resistor).
- Input and output matched to 50 ohms for ease of cascading.
- Cascaded gain blocks can be individually biased for the lowest supply current.

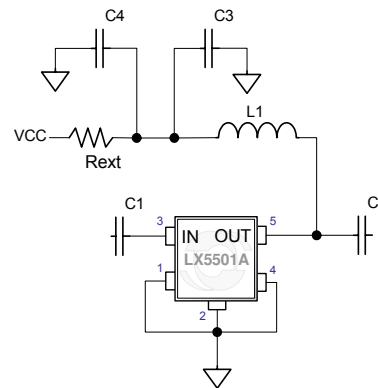
PACKAGE ORDER INFO

$T_A(^{\circ}\text{C})$	SE	Plastic SOT-23 5 pin
		RoHS Compliant / Pb-free Transition DC: 0503
-40 to +85°C		LX5501ASE

Note: Available in Tape & Reel. Append the letters "TR" to the part number. (i.e. LX5501ASE-TR)

ABSOLUTE MAXIMUM RATINGS

DC Supply Voltage6V
 Collector Current 100mA
 RF Input Power 10dBm
 Operating Temperature Range -40 to +85°C
 Storage Temperature Range -65°C to 150°C
 Peak Package Solder Reflow Temp. (40 second max. exposure) ... 260°C (+0, -5)

Note: Exceeding these ratings could cause damage to the device. All voltages are with respect to Ground. Currents are positive into, negative out of specified terminal.

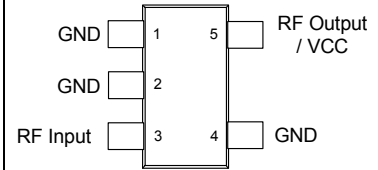
PACKAGE PIN OUT

SE PACKAGE
(Top View)

RoHS / Pb-free 100% Matte Tin Lead Finish

FUNCTIONAL PIN DESCRIPTION

Pin No.	Description
1	Ground
2	Ground
3	RF Input
4	Ground
5	RF Output/VCC Supply

RECOMMENDED OPERATING CONDITIONS

Parameter	Symbol	LX5501A			Units
		Min	Typ	Max	
Supply Voltage (with appropriate external resistor)	VCC	3.5		6	V
Quiescent Current (No RF input)	I _{cq}	10		40	mA

ELECTRICAL CHARACTERISTICS

Conditions: +25°C, 5V supply voltage.

Parameter	Symbol	Test Conditions	LX5501A			Units
			Min	Typ	Max	
GENERAL SPECIFICATIONS (FIG 1. TEST CIRCUIT)						
Small Signal Gain	S21	Frequency = 5.8 GHz		11.4		dB
P1dB Compression	P1dB	Frequency = 5.8 GHz		11.5		dBm
Input Return Loss	S11	Frequency = 2.4-6 GHz		-10		dB
Output Return Loss	S22	Frequency = 2.4-6 GHz		-10		dB
Isolation	S12	Frequency = 2.4-6 GHz		-20		dB
Harmonics		Frequency = 5.8 GHz, P _{out} = 10 dBm		-30		dBc
Quiescent Current	I _{cq}			30		mA

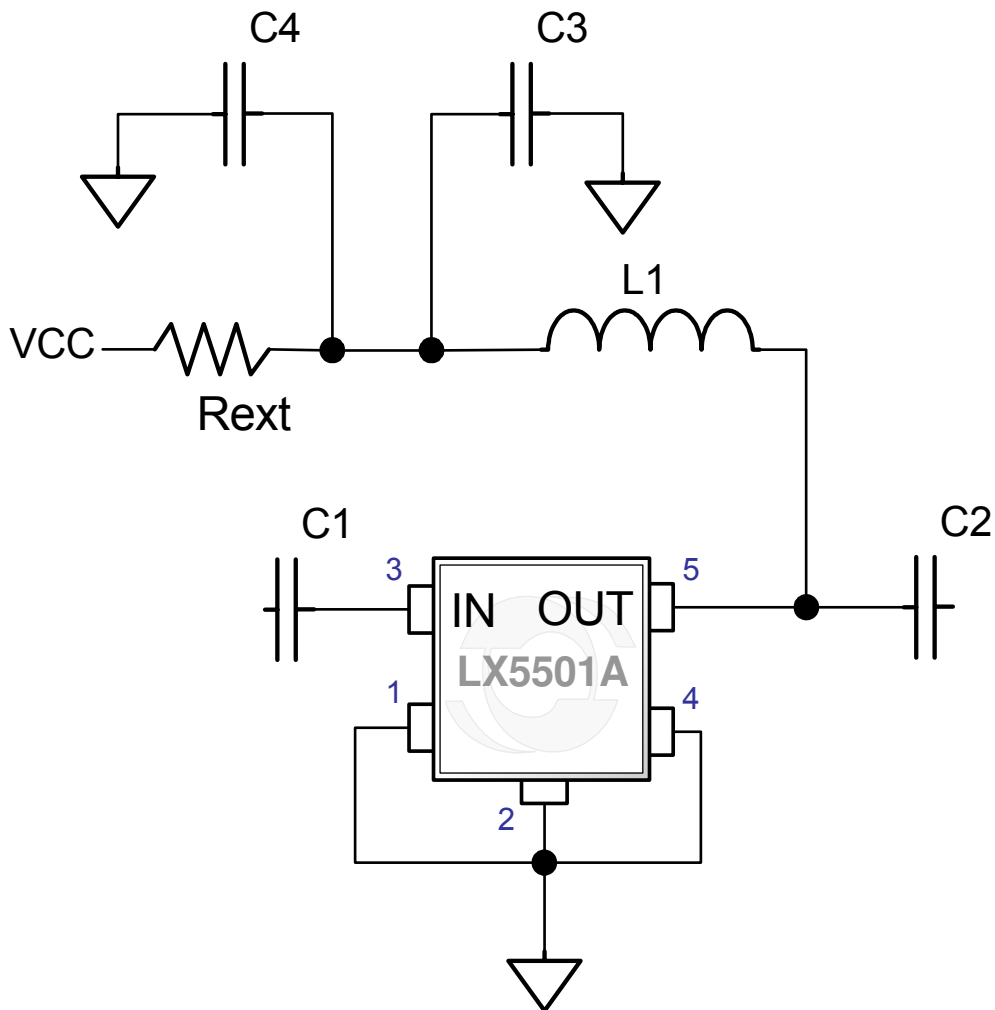
FIGURE 1: TEST CIRCUIT FOR 1 TO 6 GHz

Component	Value	Comment
C1,C2	10pF	DC block (0402)
C3	10pf	RF decoupling (0402)
C4	0.1uF	LF decoupling (0402)
L1	3.3nH	RF choke (0402)
R _{EXT}	50 ohms	Bias setting resistor (0402)

APPLICATION NOTE
DESIGN CONSIDERATIONS

The gain block is self-biased by the voltage that is present on pin 5 (V_{BIAS}). Chart 1 shows the quiescent current vs. bias voltage characteristic. Chart 2 shows device characteristics when operated with a 5v supply and with different values of external resistor. Using Chart 2 it is possible to trade-off Gain and P1dB compression point for supply current.

Supply voltages other than 5v may be accommodated by adjusting the value of the external resistor to produce the same quiescent current as the 5v case. To calculate the resistor required for a different supply voltage use the following formula:

$$R_{EXT}(V1) = R_{EXT}(5V) \cdot (V1 - V_{BIAS}) / (5 - V_{BIAS})$$

Where V_{BIAS} is the Pin 5 bias voltage obtained from Chart 1 and $V1$ is the desired supply voltage.

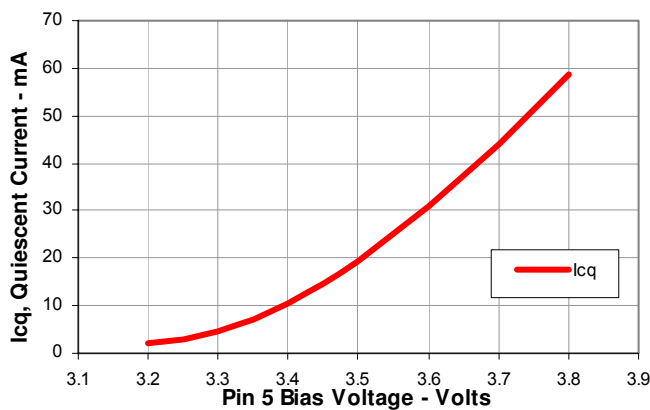
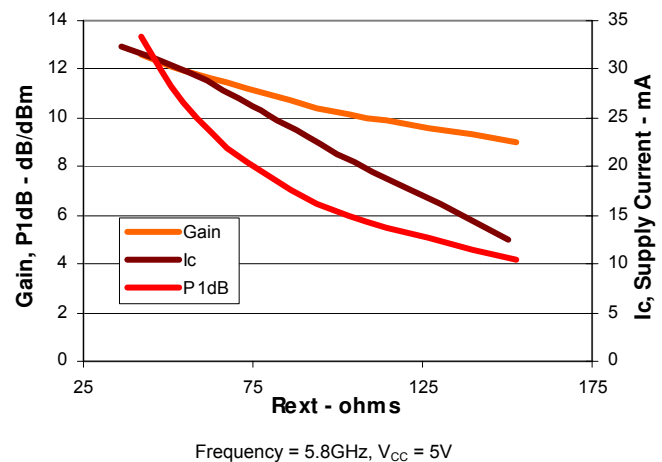
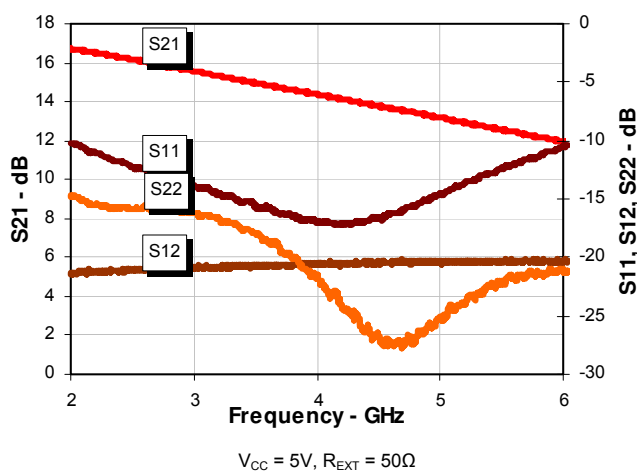
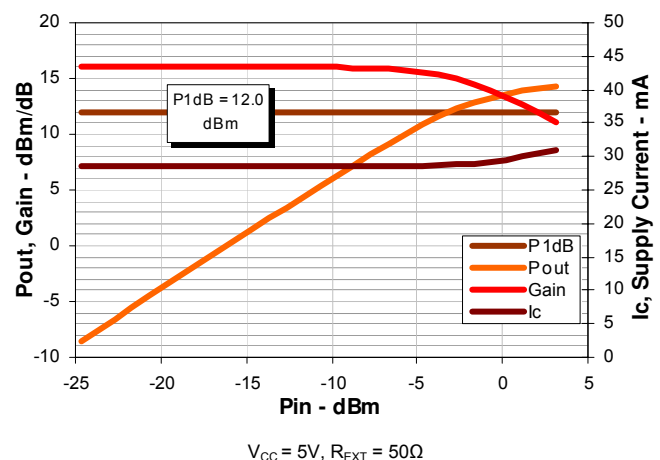
TYPICAL QUIESCENT CURRENT VS. PIN 5 BIAS VOLTAGE @ 25°C

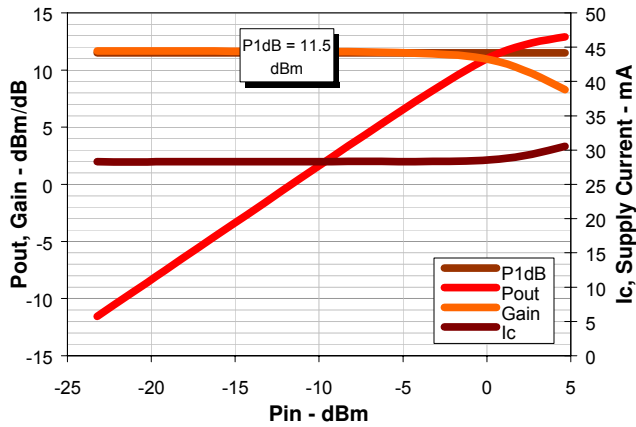
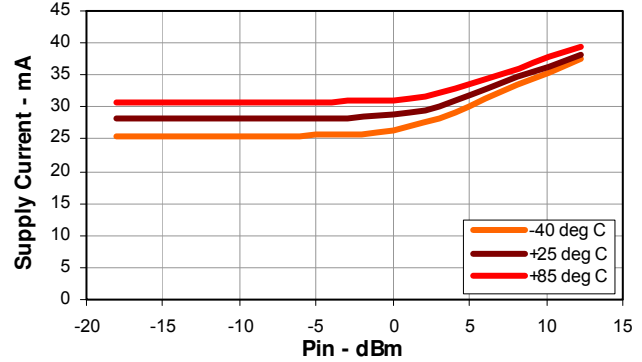
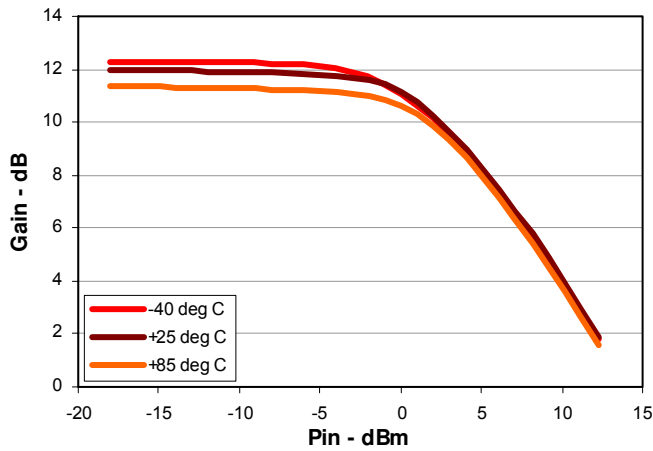
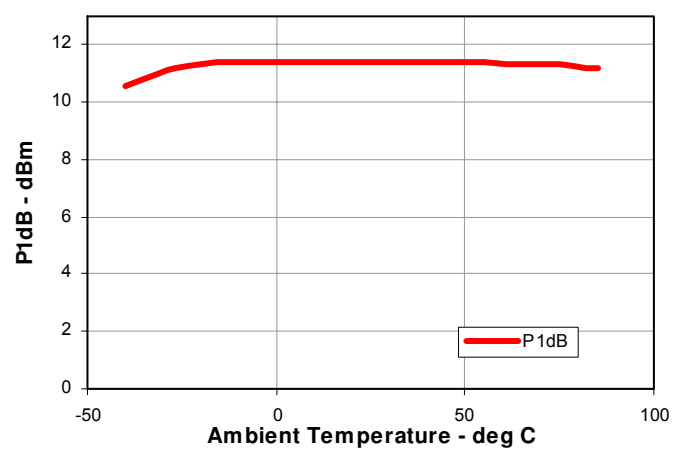
TYPICAL P1dB, GAIN AND I_C VS. R_{EXT} @ 25°C

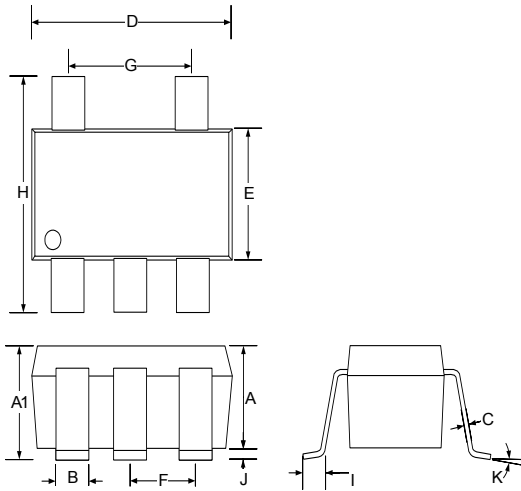
TYPICAL S-PARAMETERS @ 25°C

TYPICAL 2.4 GHz CHARACTERISTICS @ 25°C

TYPICAL 5.8 GHz CHARACTERISTICS @ 25°C

TYPICAL SUPPLY CURRENT VARIATION OVER -40 TO +85°C AMBIENT

TYPICAL GAIN VARIATION OVER -40 TO +85°C AMBIENT

TYPICAL P1dB VARIATION OVER -40 TO +85°C AMBIENT

PACKAGE DIMENSIONS
SE 5 Pin Plastic SOT-23

Dim	MILLIMETERS		INCHES	
	MIN	MAX	MIN	MAX
A	0.90	1.30	0.035	0.051
A1	0.90	1.45	0.035	0.057
B	0.25	0.50	0.010	0.020
C	0.09	0.20	0.004	0.008
D	2.80	3.10	0.110	0.122
E	1.50	1.75	0.059	0.069
F	0.95 BSC		0.038 BSC	
G	1.90 BSC		0.075 BSC	
H	2.60	3.00	0.102	0.118
I	0.35	0.55	0.014	0.022
J	0.00	0.15	0.000	0.006
K	10° MAX		10° MAX	

Note:

- Dimensions do not include mold flash or protrusions; these shall not exceed 0.155mm(.006") on any side. Lead dimension shall not include solder coverage.



Microsemi[®]

LX5501A

InGAP HBT Gain Block

PRODUCTION DATA SHEET

NOTES

PRODUCTION DATA – Information contained in this document is proprietary to Microsemi and is current as of publication date. This document may not be modified in any way without the express written consent of Microsemi. Product processing does not necessarily include testing of all parameters. Microsemi reserves the right to change the configuration and performance of the product and to discontinue product at any time.