

PRODUCTION DATA SHEET
DESCRIPTION

The LX5516 is a power amplifier module optimized for WLAN applications in the 2.4-2.5GHz frequency range. The PAM is implemented as a two-stage monolithic microwave integrated circuit (MMIC) with on-chip active bias and 50 Ω impedance matched at both input and output.

The device is manufactured with an InGaP/GaAs Heterojunction Bipolar Transistor (HBT) IC process (MOCVD). With single low voltage supply of 3.3V, it delivers 29dB power gain between 2.4-2.5GHz, at a low quiescent current of 80mA.

For 18dBm OFDM output power module (64QAM, 54Mbps), the PAM provides a low EVM (Error-Vector Magnitude) of 2.5%, and consumes 130mA total DC current.

The LX5516 is available in a 12-pin 2x2mm micro-lead package (MLPQ-12L). The compact footprint, ultra low profile, and thermal capability of the MLP package make the LX5516 an ideal solution for high-gain power amplifier requirements for IEEE 802.11b/g/n applications.

KEY FEATURES

- Advanced InGaP HBT
- 2.4-2.5GHz Operation
- Single-Polarity 3.3V Supply
- Quiescent Current ~80mA
- Power Gain ~ 29 dB
- Pout=+18dBm for 2.5% EVM, OFDM 64QAM/54Mbps
- Total Current ~130mA for Pout=+18dBm
- 50Ω Input/Output Matching
- On-chip Output Power Detector
- Small Footprint: 2x2mm²
- Ultra Low Profile:0.46mm

APPLICATIONS

- IEEE 802.11b/g/n

IMPORTANT: For the most current data, consult MICROSEMI's website: <http://www.microsemi.com>

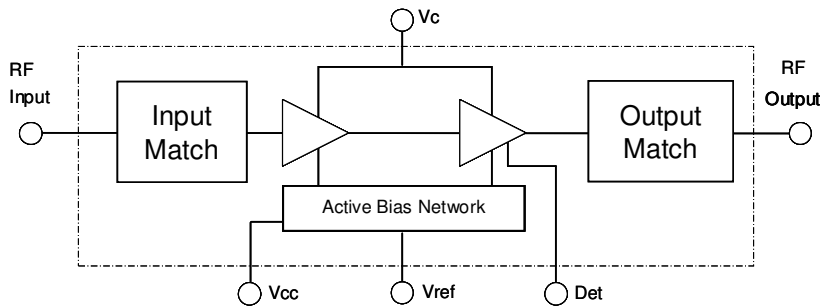
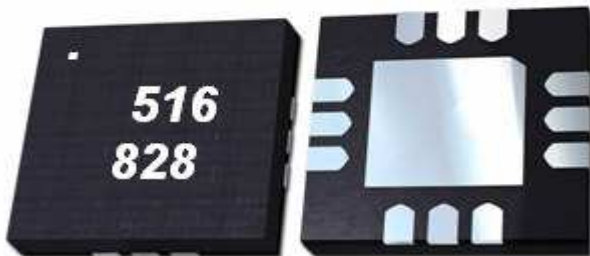
BLOCK DIAGRAM

2X2MM MLP PACKAGE

PACKAGE ORDER INFO

LL Plastic MLPQ
12 pin 2x2mm
LX5516LL

Note: Available in Tape & Reel. Append the letters "TR" to the part number. (i.e. LX5516LL-TR)

PRODUCTION DATA SHEET
ABSOLUTE MAXIMUM RATINGS

DC Supply Voltage, RF off	5V
Collector Current.....	500mA
Total Power Dissipation	2W
RF Input Power (With 50 Ohm Load at Output).....	+10 dBm
Maximum operating Junction Temperature (T _J).....	150 °C
Operation Ambient Temperature	-40 to +85 °C
Storage Temperature.....	-60 to +150 °C
Package Peak Temp. for Solder Reflow (40 seconds maximum exposure).....	260 °C (+0 -5)

Note: Exceeding these ratings could cause damage to the device. All voltages are with respect to Ground. Currents are positive into, negative out of specified terminal.

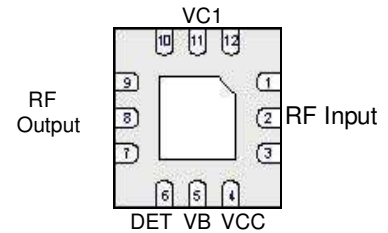
PACKAGE PIN OUT

LL PACKAGE
(Bottom View)

RoHS / Pb-free 100% NiPdAu Lead Finish

THERMAL DATA
LL Plastic MLPQ 12-Pin

THERMAL RESISTANCE-JUNCTION TO CASE, θ_{JC}	7.9 C/W
THERMAL RESISTANCE-JUNCTION TO AMBIENT, θ_{JA}	76.5 C/W

Junction Temperature Calculation: $T_J = T_A + (P_D \times \theta_{JA})$.

The θ_{JA} numbers are guidelines for the thermal performance of the device/pc-board system. All of the above assume no ambient airflow.

FUNCTIONAL PIN DESCRIPTION

Name	Description
RF IN (2)	RF input for the power amplifier.
VCC (4)	Supply voltage for the bias reference and control circuits.
VB (5)	Bias control voltage for the first and second stage.
DET(6)	Output power Detector.
RF OUT(8)	RF output and power supply for the second stage amplifier.
VC1(11)	DC supply voltage for the first stage amplifier.
GND	The center metal base of the MLP package provides both DC/RF ground as well as heat sink for the power amplifier.
(1,3,7,9,10,12)	PINs to be grounded to the center metal on the PCB.



Microsemi[®]

INFORMATION

Thank you for your interest in Microsemi[®] Analog Mixed Signal products.

The full data sheet for this device contains proprietary information.

To obtain a copy, please contact your local Microsemi sales representative. The name of your local representative can be obtained at the following link

<http://www.microsemi.com/contact/contactfind.asp>

or

Contact us directly by sending an email to:

IPGdatasheets@microsemi.com

Be sure to specify the data sheet you are requesting and include your company name and contact information and or vcard.

We look forward to hearing from you.