

DESCRIPTION

The LX5510B is a power amplifier optimized for WLAN applications in the 2.4-2.5 GHz frequency range. The PA is implemented as a two-stage monolithic microwave integrated circuit (MMIC) with active bias and input/output pre-matching.

The device is manufactured with an InGaP/GaAs Heterojunction Bipolar Transistor (HBT) IC process (MOCVD). With a single supply of 3.3 volts and a low quiescent current of 70mA the power gain is 19dB 2.4 – 2.5GHz.

For +19dBm OFDM output power (64QAM, 54Mbps), the PA provides a low EVM (Error-Vector Magnitude) of 3.0%, and consumes 135mA total DC current with the nominal 3.3V bias.

The LX5510B is available in a 16-pin 3mmx3mm micro-lead package (MLP). The compact footprint, low profile, and excellent thermal capability of the MLP package makes the LX5510B an ideal solution for medium-gain power amplifier requirements for IEEE 802.11b/g applications

KEY FEATURES

- Advanced InGaP HBT
- 2.4 – 2.5GHz Operation
- Single-Polarity 3.3V Supply
- Low Quiescent Current I_{CQ} ~70mA
- Power Gain ~19dB @ 2.45GHz and P_{out} = 19dBm
- Total Current 135mA for P_{out} = 19dBm @ 2.45GHz OFDM
- EVM ~ 3.0% for 64QAM / 54Mbps and P_{out} = 19dBm
- Small Footprint (3 x 3 mm²)
- Low Profile (0.9mm)

APPLICATIONS

- IEEE 802.11b/g

IMPORTANT: For the most current data, consult MICROSEMI's website: <http://www.microsemi.com>

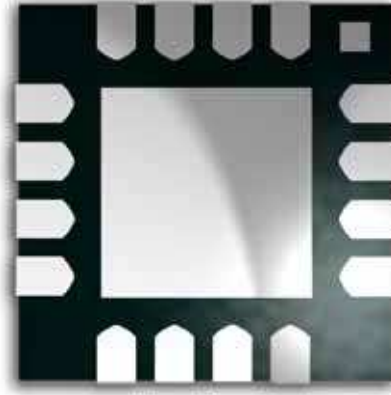
PRODUCT HIGHLIGHT

PACKAGE ORDER INFO

T_A (°C)	LQ	Plastic MLPQ 16 pin
		RoHS Compliant / Pb-free
0 to 70		LX5510BLQ

Note: Available in Tape & Reel. Append the letters "TR" to the part number. (i.e. LX5510BLQ-TR)

This device is classified as EDS Level 1 in accordance with MIL-STD-883, Method 3015 (HBM) testing. Appropriate ESD procedures should be used when handling this device.

ABSOLUTE MAXIMUM RATINGS

DC Supply Voltage, RF off	6V
Collector Current	400mA
Total Power Dissipation.....	2W
RF Input Power	15dBm
Operation Ambient Temperature	-40°C to +85°C
Storage Temperature.....	-65°C to +150°C
Package Peak Temp. for Solder Reflow (40 seconds maximum exposure)	260°(+0, -5)

Note: Exceeding these ratings could cause damage to the device. All voltages are with respect to Ground. Currents are positive into, negative out of specified terminal.

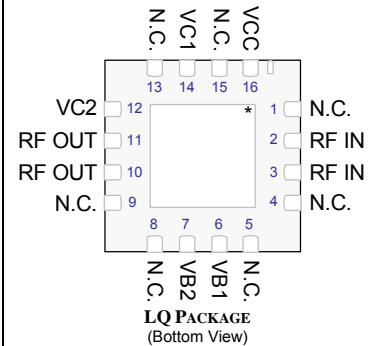
PACKAGE PIN OUT

RoHS / Pb-free 100% Matte Tin Lead Finish

THERMAL DATA
LQ Plastic MLPQ 16-Pin

THERMAL RESISTANCE-JUNCTION TO CASE, θ_{JC}	10°C/W
THERMAL RESISTANCE-JUNCTION TO AMBIENT, θ_{JA}	50°C/W

FUNCTIONAL PIN DESCRIPTION

Name	Description
RF IN	RF input for the power amplifier. This pin is DC-short to GND but AC-coupled to the transistor base of the first stage.
VB1	Bias current control voltage for the first stage.
VB2	Bias current control voltage for the second stage. The VB2 pin can be connected with the first stage control voltage (VB1) into a single reference voltage (referred to as V_{REF}) through an external resistor bridge.
VCC	Supply voltage for the bias reference and control circuits. This pin can be combined with both VC1 and VC2 pins, resulting in a single supply voltage (referred to as V_C).
RF OUT	RF output for the power amplifier.
VC1	Power supply for first stage amplifier. The VC1 feed line should be terminated with a 3.9pF bypass capacitor 50 mil apart from the device, followed by a 8.2nH blocking inductor at the supply side. This pin can be combined with VC2 and VCC pins, resulting in a single supply voltage (referred to as V_C).
VC2	Power supply for second stage amplifier. The VC2 feed line should be driven with a 8.2nH AC blocking inductor and 1μF bypass capacitor. This pin can be combined with VC1 and VCC pins, resulting in a single supply voltage (referred to as V_C).
GND	The center metal base of the MLP package provides both DC and RF ground as well as heat sink for the power amplifier.

ELECTRICAL CHARACTERISTICS

Unless otherwise specified, the following specifications apply over the operating ambient temperature $0^{\circ}\text{C} \leq T_A \leq 70^{\circ}\text{C}$ except where otherwise noted and the following test conditions: $V_C = 3.3\text{V}$, $V_{REF} = 2.88\text{V}$, $I_{CQ} = 70\text{mA}$, $T_A = 25^{\circ}\text{C}$

Parameter	Symbol	Test Conditions	LX5510B			Units
			Min	Typ	Max	
SECTION HEADER						
Frequency Range	f		2.4		2.5	GHz
Power Gain at $P_{OUT} = 19\text{dBm}$	G_P			19		dB
EVM at $P_{out} = 19\text{dBm}$		64QAM / 54Mbps OFDM		3.0		%
Total Current @ $P_{OUT} = 19\text{dBm}$	I_{C_TOTAL}			135		mA
Quiescent Current	I_{CQ}			70		mA
Bias Control Reference Current	I_{REF}	For $I_{CQ} = 70\text{mA}$		1.5		mA
Small-Signal Gain	S21			19		dB
Gain Flatness	$\Delta S21$	Over 100MHz		± 0.5		dB
Gain Variation Over Temperature	$\Delta S21$	0°C to $+70^{\circ}\text{C}$		± 0.5		dB
Input Return Loss	S11			10		dB
Output Return Loss	S22			10		dB
Reverse Isolation	S12			40		dB
Second Harmonic		$P_{out} = 19\text{dBm}$		-55		dBc
Third Harmonic		$P_{out} = 19\text{dBm}$		-55		dBc
2 nd Side Lobe		23 dBm 11 Mbps CCK		-50		dBc
Total current $P_{out}=23\text{ dBm}$		11 Mbps CCK		190		mA
Ramp-On Time	t_{ON}	10 ~ 90%			100	ns

Note: All measured data was obtained on a 10 mil GETEK evaluation board without heat sink.

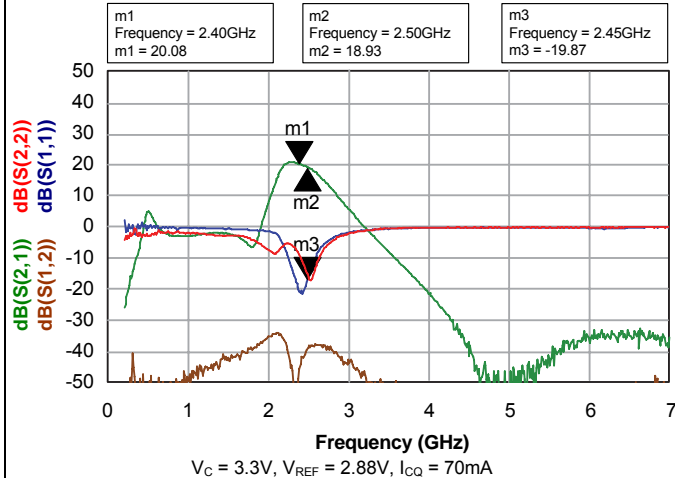
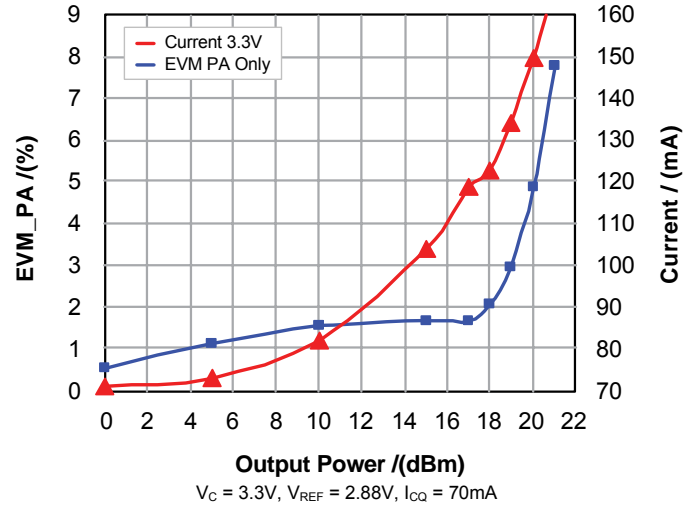
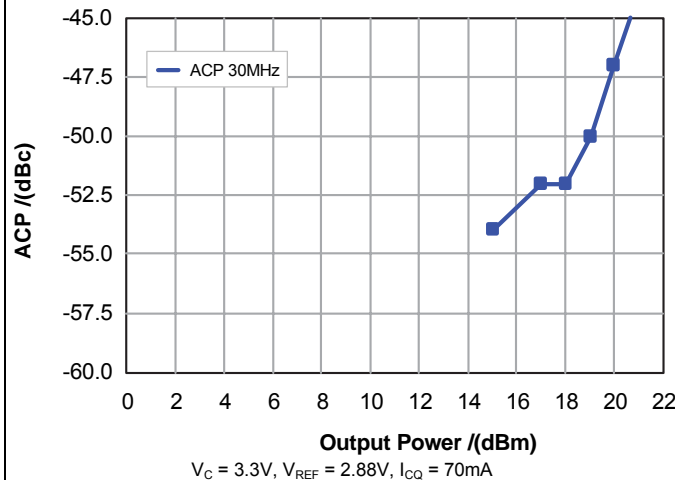
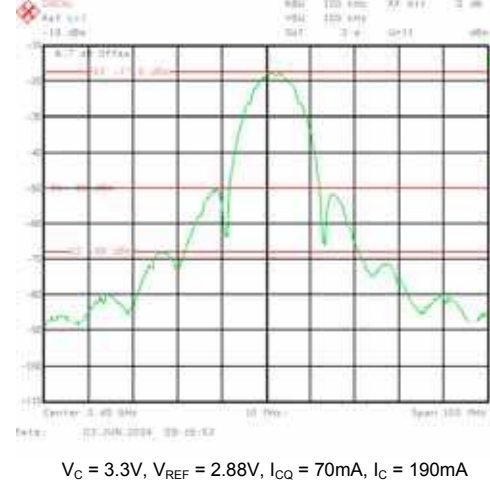
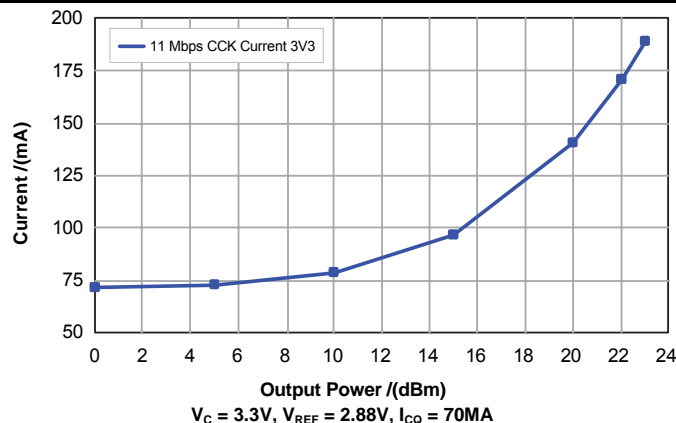
S PARAMETER DATA

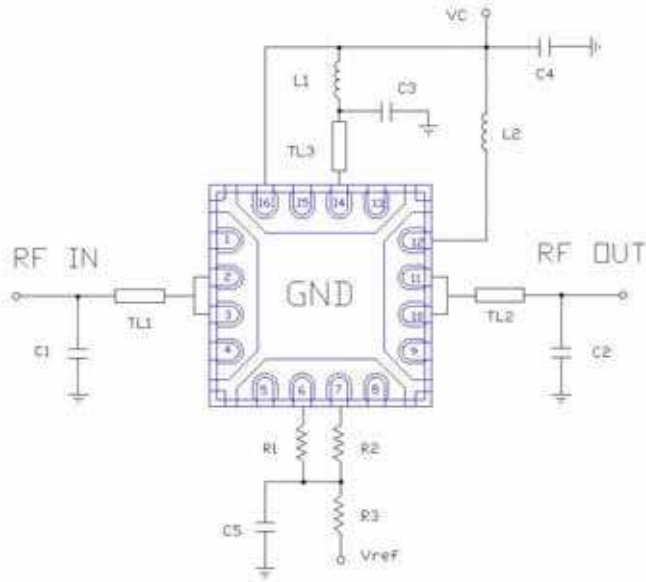
EVM DATA WITH 54MB/S64QAM OFDM

ACP DATA WITH 54MB/S 64 QAM OFDM

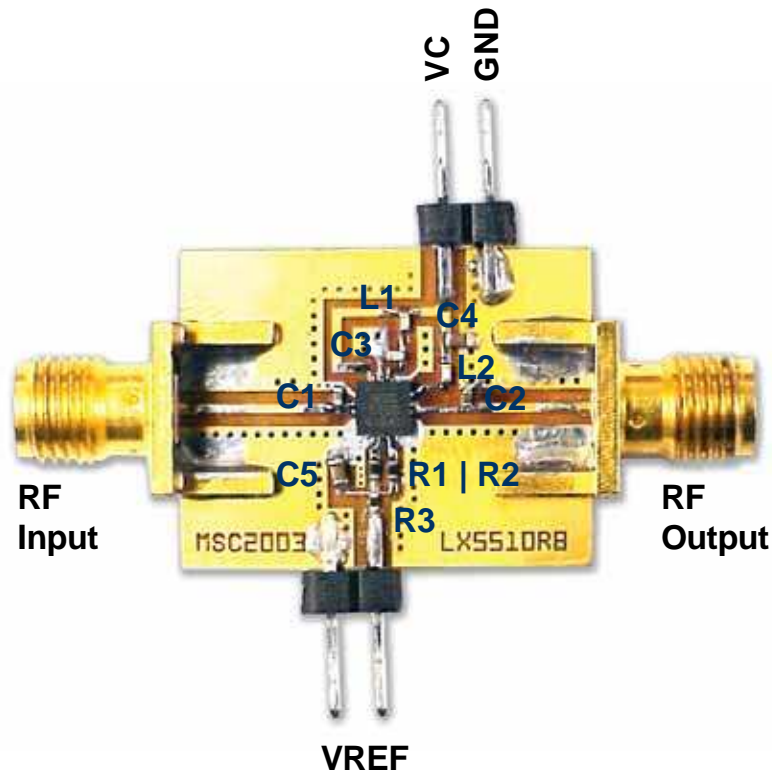
SPECTRUM WITH 23DBM 11MB/S CCK

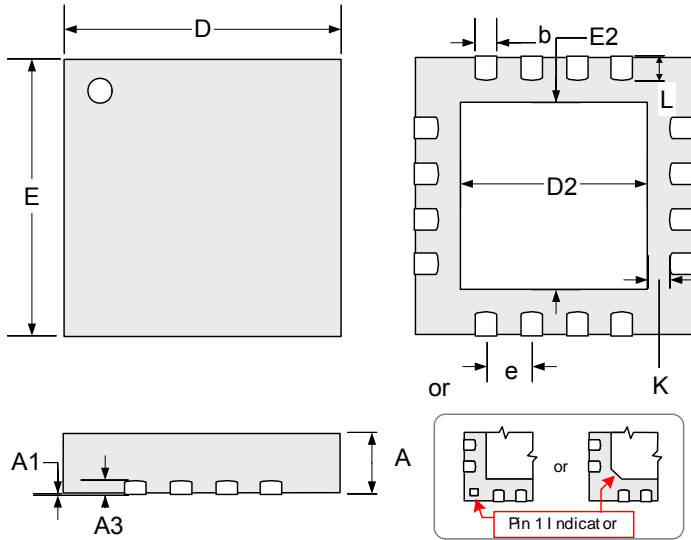
SUPPLY CURRENT WITH 11MB/S CCK

EVALUATION BOARD

Recommended BOM

Location	Value
C1	2.7pF (0402)
C2	2.4pF (0402)
C3	3.9pF (0402)
C4,C5	1 μ F (0603)
L1,L2	8.2nH(0402)
R1	350 Ω (0402)
R2	200 Ω (0402)
R3	100 Ω (0402)
TL1	30/22 mil (L/W)
TL2	100/10 mil (L/W)
TL3	60/10 mil (L/W)
Substrate	10 mil GETEK
	$\epsilon_r = 3.9$, $\tan \delta = 0.01$
	50 Ω Microstrip width: 22 mil

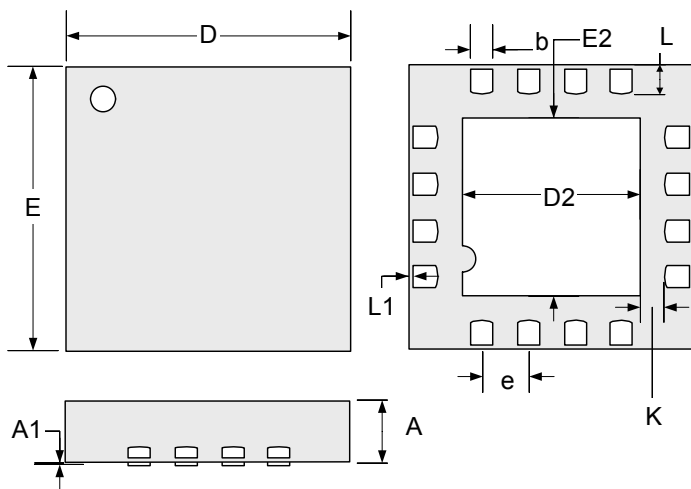

PACKAGE DIMENSIONS
LQ 16-Pin MLPQ 3x3

Or



Dim	MILLIMETERS		INCHES	
	MIN	MAX	MIN	MAX
A	0.80	1.00	0.031	0.039
A1	0	0.05	0	0.002
A3	0.20 REF		0.008 REF	
b	0.18	0.30	0.007	0.012
D	3.00 BSC		0.118 BSC	
E	3.00 BSC		0.118 BSC	
e	0.50 BSC		0.020 BSC	
D2	1.30	1.55	0.051	0.061
E2	1.30	1.55	0.051	0.061
K	0.2	-	0.008	-
L	0.35	0.50	0.012	0.020
L1	-	0.15	-	0.006

Note:

- Dimensions do not include mold flash or protrusions; these shall not exceed 0.155mm(.006") on any side. Lead dimension shall not include solder coverage.
- Due to multiple qualified assembly sub-contractors either package (with different pin one indicators) may be shipped. Package type will be consistent within the smallest individual container.



TAPE AND REEL

Tape And Reel Specification

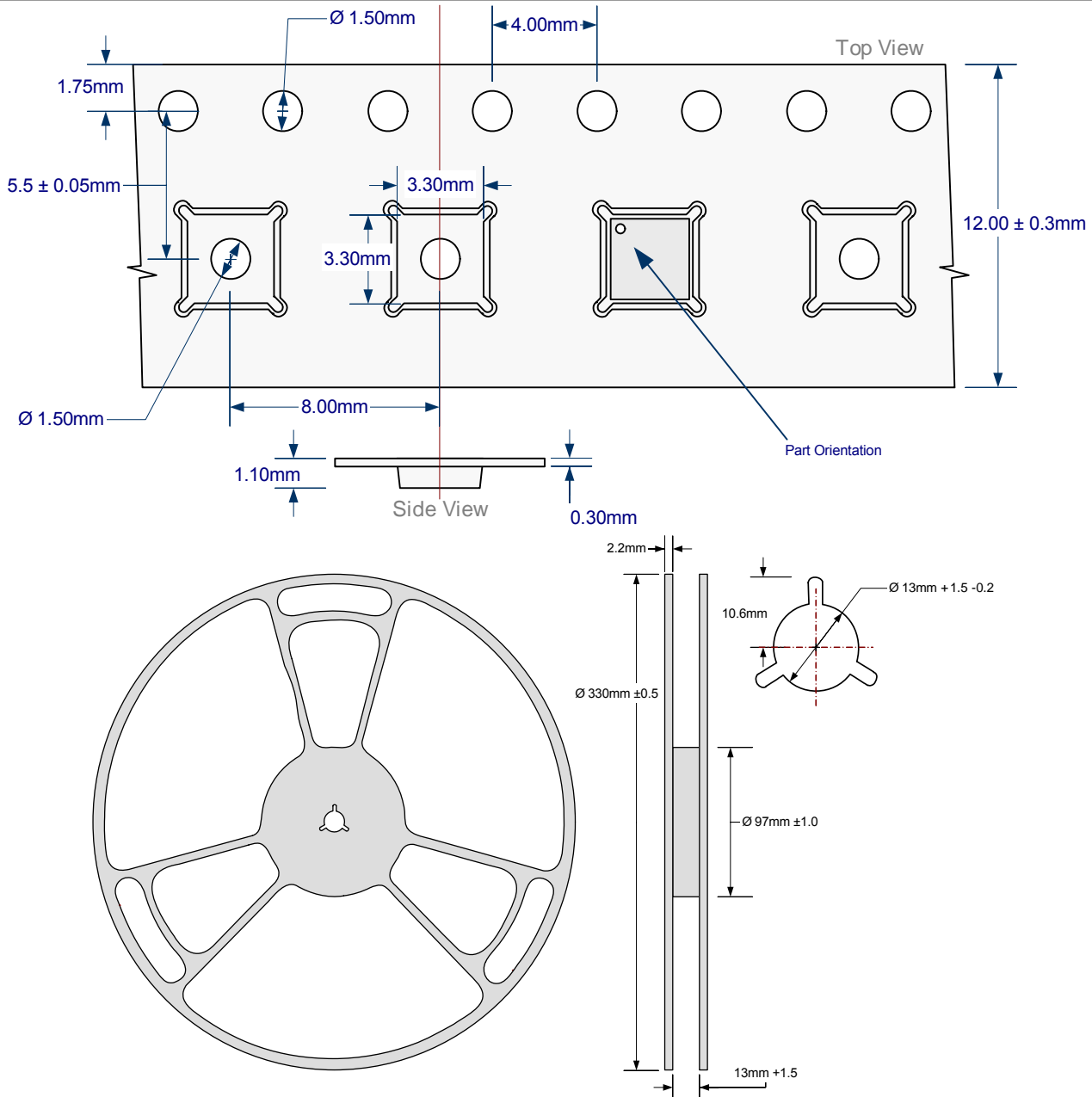



Microsemi[®]

LX5510B

InGaP HBT 2.4 – 2.5 GHz Power Amplifier

PRODUCTION DATA SHEET

NOTES

PRODUCTION DATA – Information contained in this document is proprietary to Microsemi and is current as of publication date. This document may not be modified in any way without the express written consent of Microsemi. Product processing does not necessarily include testing of all parameters. Microsemi reserves the right to change the configuration and performance of the product and to discontinue product at any time.