

DESCRIPTION

The LX5512E is a power amplifier optimized for WLAN applications in the 2.4-2.5 GHz frequency range. The PA is implemented as a three-stage monolithic microwave integrated circuit (MMIC) with active bias and input/output pre-matching. The device is manufactured with an InGaP/GaAs Heterojunction Bipolar Transistor (HBT) IC process (MOCVD). It operates at a single low voltage supply of 3.3V with 34 dB power gain between 2.4-2.5GHz, at a low quiescent current of 50 mA.

For 19dBm OFDM output power (64QAM, 54Mbps), the PA provides a low EVM (Error-Vector Magnitude) of 3 %, and consumes 130 mA total DC current.

The LX5512E is available in a 16-pin 3mmx3mm micro-lead package (MLP). The compact footprint, low profile, and excellent thermal capability of the MLP package makes the LX5512E an ideal solution for high-gain power amplifier requirements for IEEE 802.11b/g applications.

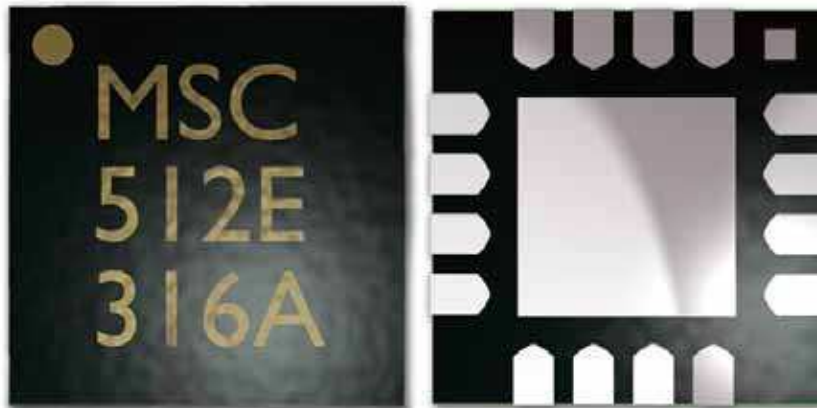
IMPORTANT: For the most current data, consult *MICROSEMI*'s website: <http://www.microsemi.com>

KEY FEATURES

- Advanced InGaP HBT
- 2.4 – 2.5GHz Operation
- Single-Polarity 3.3V Supply
- Low Quiescent Current I_q ~50mA
- Power Gain ~34dB @ 2.45GHz and P_{out} = 19dBm
- Total Current 130mA for P_{out} = 19dBm @ 2.45GHz OFDM
- EVM ~ 3.0% for 64QAM / 54Mbps and P_{out} = 19dBm
- Small Footprint (3 x 3 mm²)
- Low Profile (0.9mm)

APPLICATIONS

- IEEE 802.11b/g

PRODUCT HIGHLIGHT

PACKAGE ORDER INFO

LQ Plastic MLPQ
16 pin

RoHS Compliant / Pb-free
Transition DC: 0418

LX5512ELQ

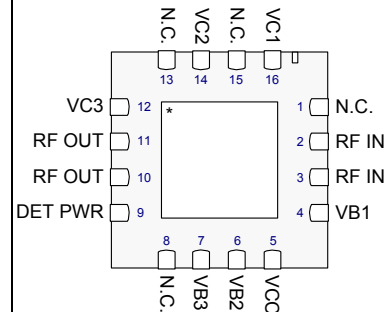
Note: Available in Tape & Reel. Append the letters "TR" to the part number. (i.e. LX5512ELQ-TR)

This device is classified as ESD Level 0 in accordance with JESD22-A114-B, (HBM) testing. Appropriate ESD procedures should be observed when handling this device.

ABSOLUTE MAXIMUM RATINGS

DC Supply Voltage, RF off	6V
Collector Current	400mA
Total Power Dissipation.....	2W
RF Input Power	5dBm
Operation Ambient Temperature	-40°C to +85°C
Storage Temperature.....	-65°C to +150°C
Peak Package Solder Reflow Temp (40 seconds maximum exposure).....	260°C (+0, -5)

Note: Exceeding these ratings could cause damage to the device. All voltages are with respect to Ground. Currents are positive into, negative out of specified terminal.

PACKAGE PIN OUT


* Pad is GND

LQ PACKAGE
(Bottom View)

N.C. – No internal connection

RoHS / Pb-free 100% Matte Tin Lead Finish

THERMAL DATA
LQ Plastic MLPQ 16-Pin

THERMAL RESISTANCE-JUNCTION TO CASE, θ_{JC}	10°C/W
THERMAL RESISTANCE-JUNCTION TO AMBIENT, θ_{JA}	50°C/W

FUNCTIONAL PIN DESCRIPTION

Name	Description
RF IN	RF input for the power amplifier. This pin is DC-shorted to GND but AC-coupled to the transistor base of the first stage.
VB1	Bias current control voltage for the first stage.
VB2	Bias current control voltage for the second stage
VB3	Bias current control voltage for the third stage. The VB3 pin can be connected with the first and second stage control voltage (VB1,VB2) into a single reference voltage (referred to as Vref) through an external resistor bridge.
VCC	Supply voltage for the bias reference and control circuits. The VCC feed line should be terminated with a 10 nF bypass capacitor close to connector pin. This pin can be combined with VC1, VC2 and VC3 pins, resulting in a single supply voltage (referred to as Vc).
RF OUT	RF output for the power amplifier. This pin is DC-decoupled from the transistor collector of the third stage..
VC1	Power supply for first stage amplifier. The VC1 feedline should be terminated with a 120pF bypass capacitor, followed by a 10 Ohm resistor
VC2	Power supply for second stage amplifier. The VC2 feedline should be terminated with a 47 pF bypass capacitor, followed by a 5 Ohm resistor
VC3	Power supply for the third stage amplifier. The VC3 feedline should be terminated with a 120 pF bypass capacitor. This pin can be combined with VC1,VC2 and VCC pins, resulting in a single supply voltage (referred to as Vc
DET_PWR	Power detector output-coupled pin should be terminated with a 100 kOhm loading resistor
GND	The center metal base of the MLP package provides both DC and RF ground as well as heat sink for the power amplifier..

ELECTRICAL CHARACTERISTICS

 Test conditions: $V_c = 3.3V$, $V_{ref} = 2.9V$, $I_{cq} = 50mA$, $T_A = 25^\circ C$, unless otherwise specified

Parameter	Symbol	Test Conditions	LX5512E			Units
			Min	Typ	Max	
Frequency Range	f		2.4		2.5	GHz
Power Gain at Pout = 19dBm	Gp			34		dB
EVM at Pout = 19dBm		64GQAM / 54Mbps		3.0		%
Total Current at Pout = 19dBm	Ic_total			130		mA
Quiescent Current	Icq			50		mA
Bias Control Reference Current	Iref	For Icq = 50mA		1.6		mA
Small-Signal Gain	S21			34		dB
Gain Flatness	$\Delta S21$	Over 100MHz		1.5		dB
Gain Variation Over Temperature	$\Delta S21$	0°C to +70°C		1.5		dB
Input Return Loss	S11			8		dB
Output Return Loss	S22			10		dB
Reverse Isolation	S12			-50		dB
Second Harmonic		Pout = 19dBm		-40		dBc
Third Harmonic		Pout = 19dbm		-40		dBc
Total Current at Pout=23dBm		11 Mbps CCK		200		mA
2 nd side lobe at 23 dBm		11 Mbps CCK		-50		dBc
Ramp-On Time	t _{ON}	10 ~ 90%			100	ns
Detector response		19 dBm OFDM, 100kOhm's		1.5		V

Note: All measured data was obtained on a 10 mil GETEK evaluation board without heat sink.



CHARACTERISTIC CURVES

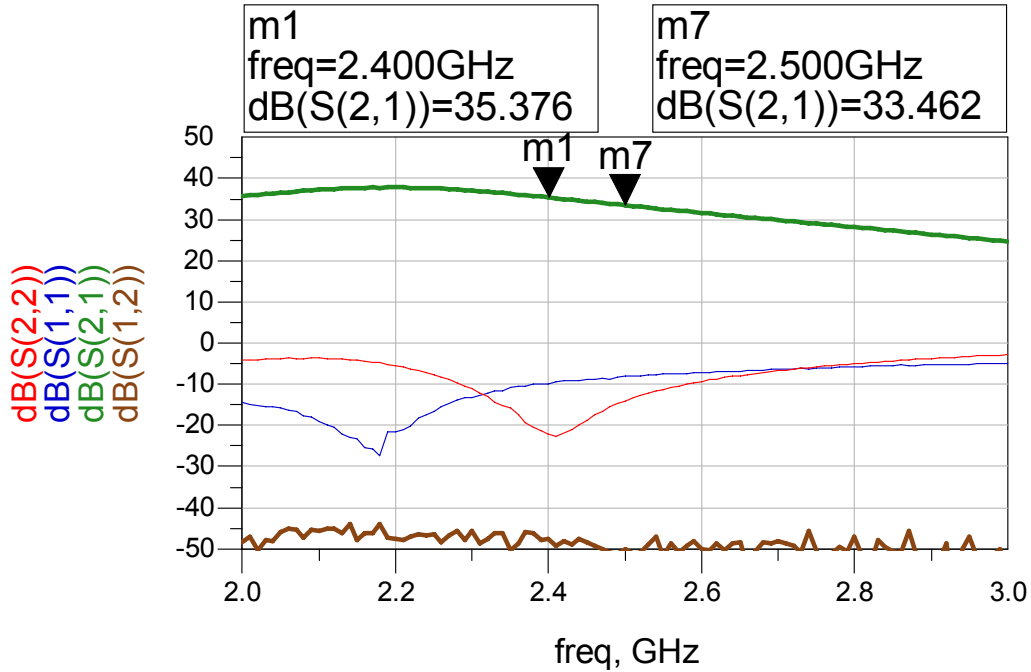


Figure 1 – S-Parameter
(Vc = 3.3V, VREF = 2.9V, Icq = 50mA)

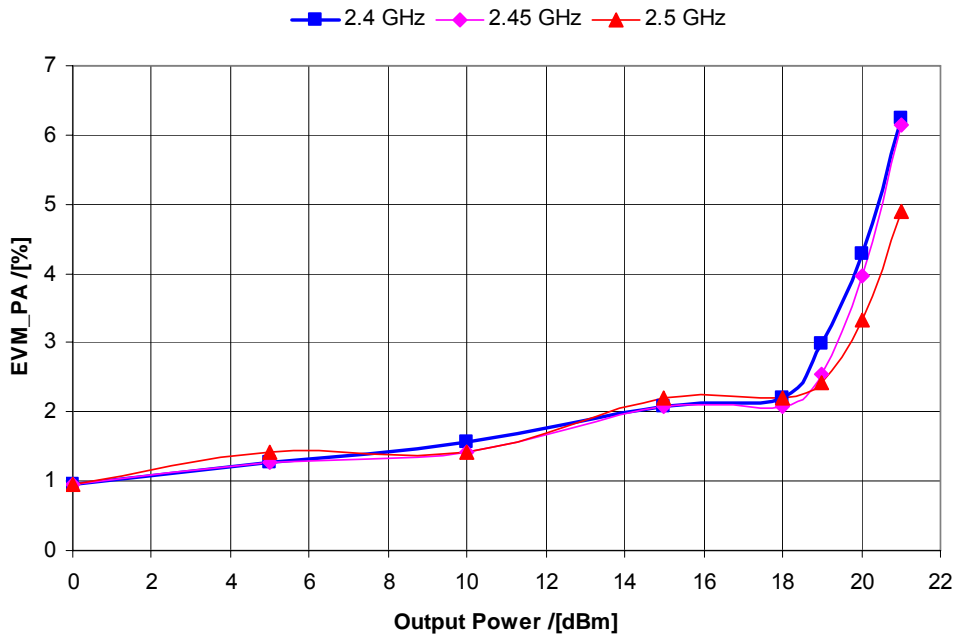


Figure 2 – EVM with 54Mb/s 64 QAM OFDM
(Vc = 3.3V, Vref = 2.9V, Icq = 50mA)

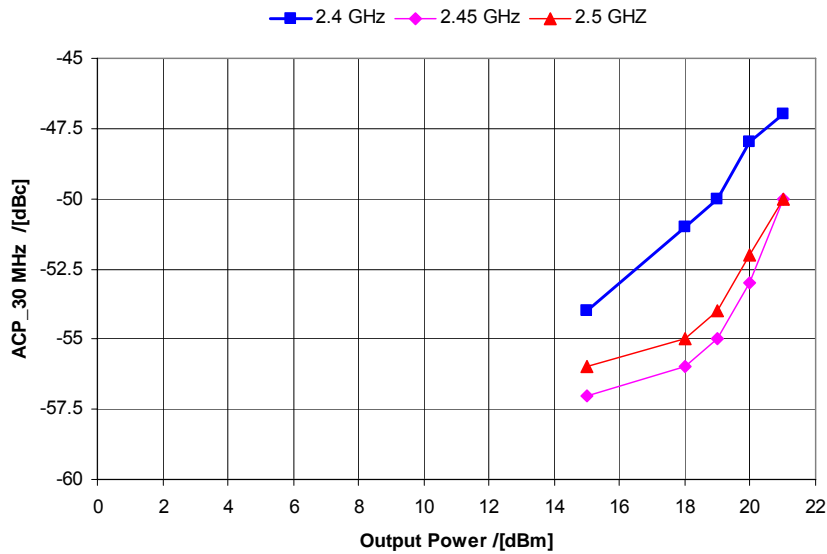
CHARACTERISTIC CURVES


Figure 3 – ACP with 54MB/s 64 QAM OFDM
 (VC = 3.3V, Vref = 2.9V, Icq = 50mA)

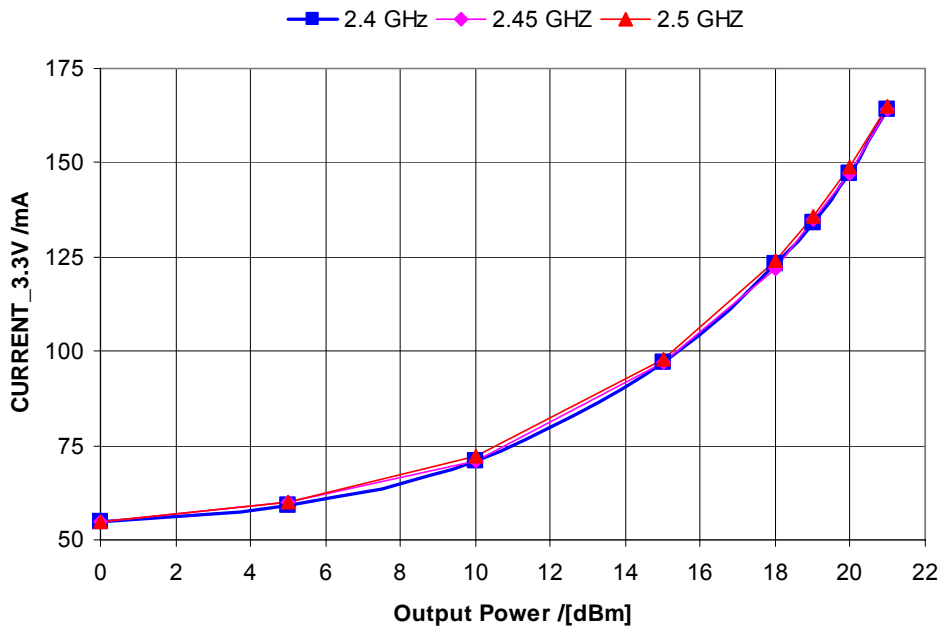


Figure 4 – Current with 54MB/s 64 QAM OFDM
 (VC = 3.3V, Vref = 2.9V, Icq = 50mA)

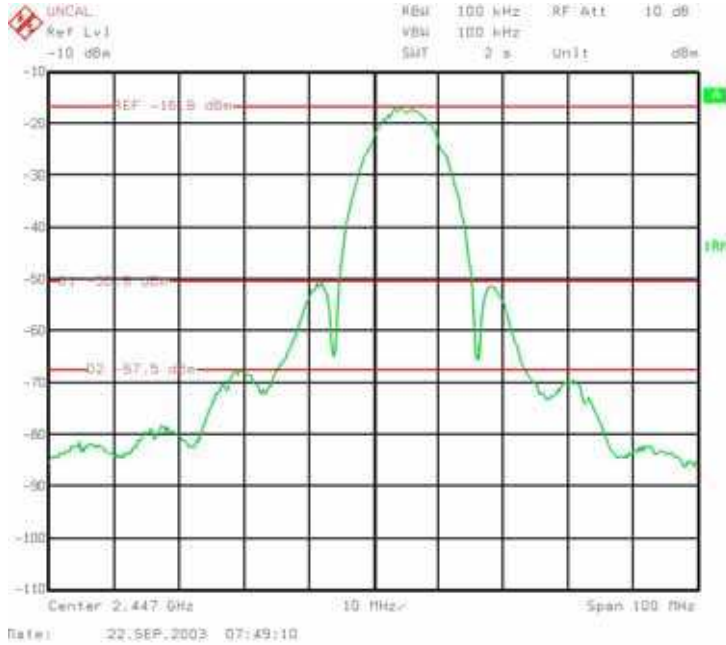
CHARACTERISTIC CURVES


Figure 5 – Spectrum with 23dBm 11Mb/s CCK
 (Vc = 3.3V, Vref = 2.9V, Icq = 50mA, Ic = 202mA, Frequency = 2.45GHz)

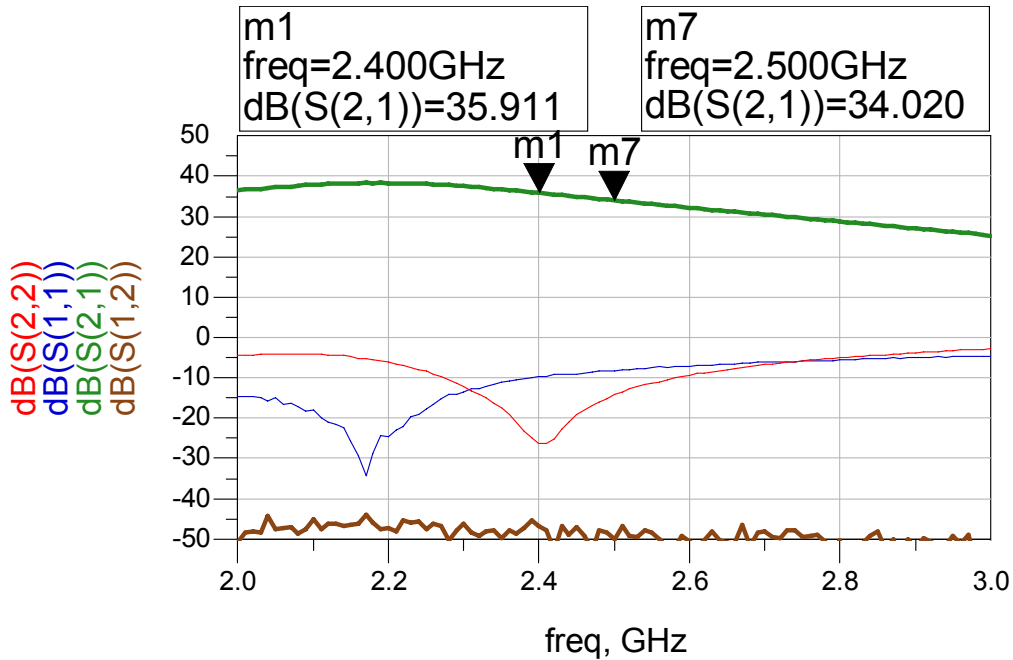


Figure 6 – S-Parameter
 (VC = 5.0V, VREF = 2.9V, Icq = 55mA)

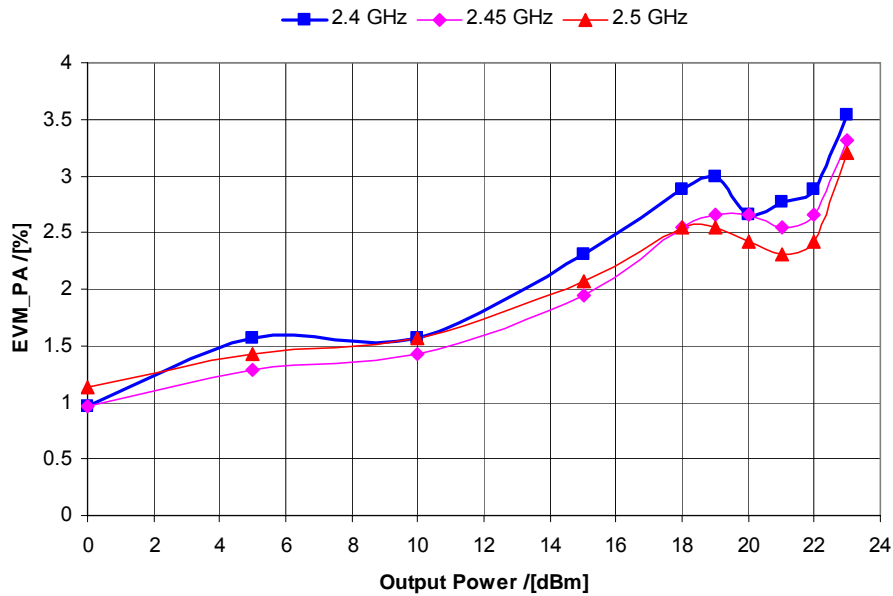
CHARACTERISTIC CURVES


Figure 7 – EVM with 54Mb/s 64QAM OFDM
 (Vc = 5V, Vref = 2.9V, Icq = 55mA,)

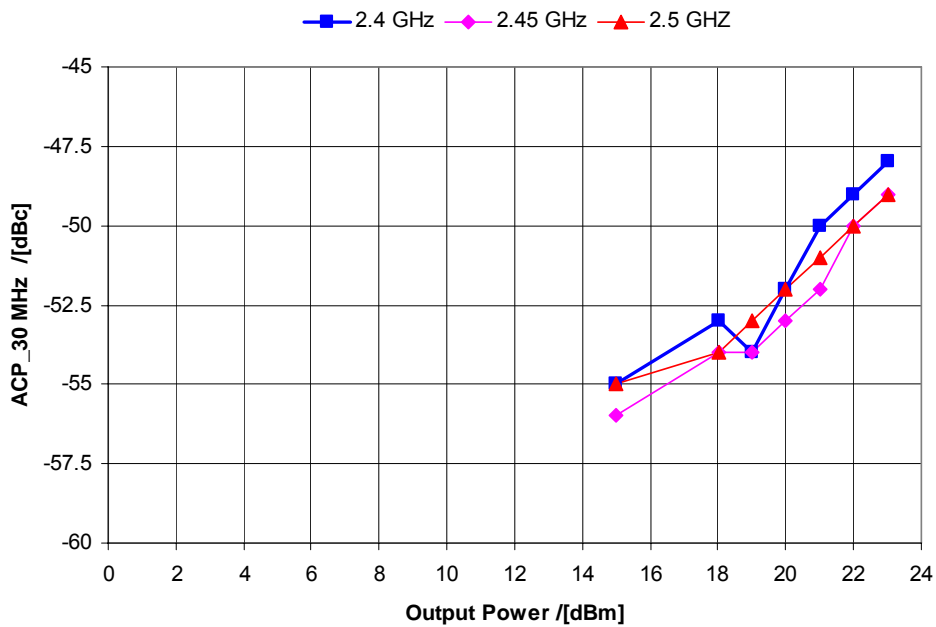


Figure 8 – ACP Data with 54Mb/s 64 QAM OFDM
 (Vc = 5V, Vref = 2.9V, Icq = 55mA)

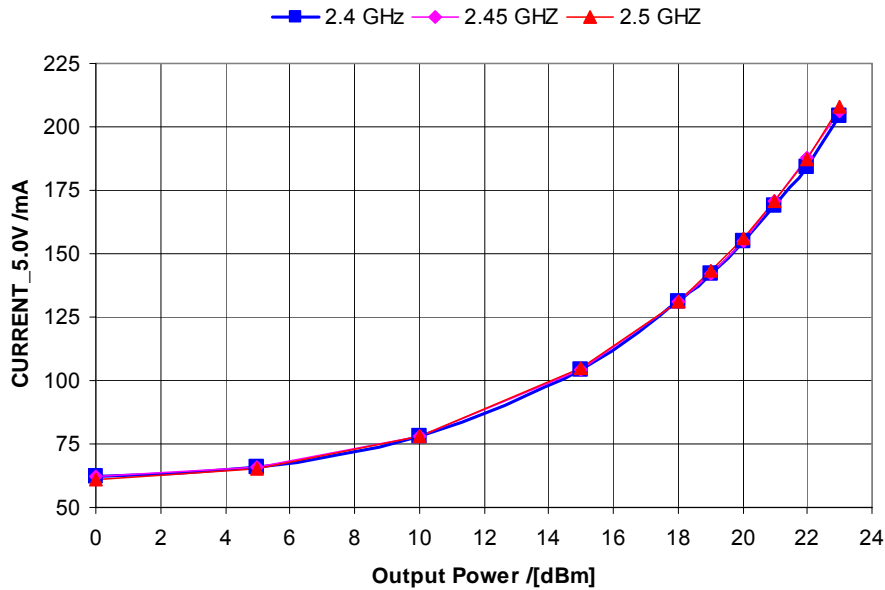
CHARACTERISTIC CURVES


Figure 9 – Current with 54MB/s 64 QAM OFDM
($V_C = 5.0V$, $V_{ref} = 2.9V$, $I_{cq} = 55mA$)

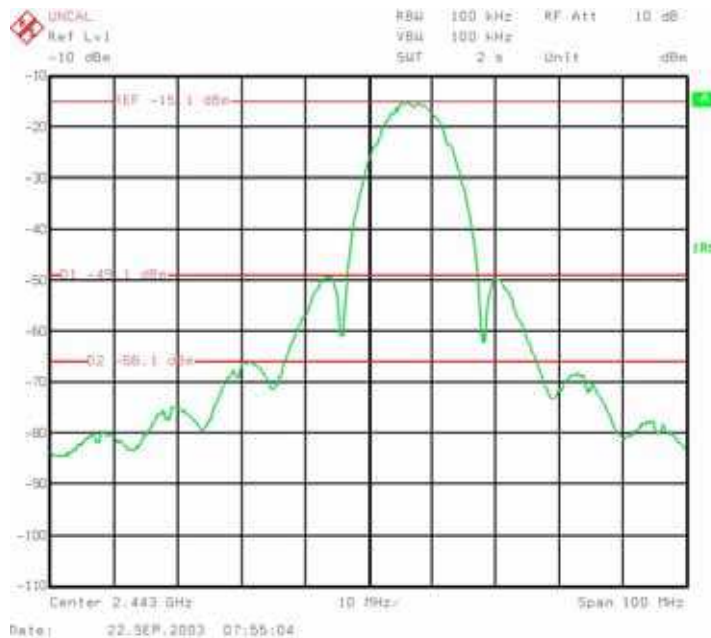
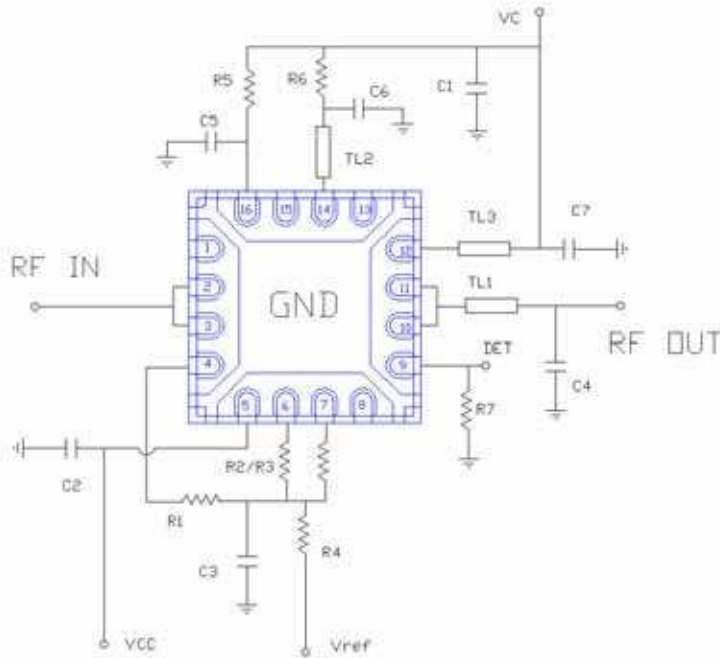
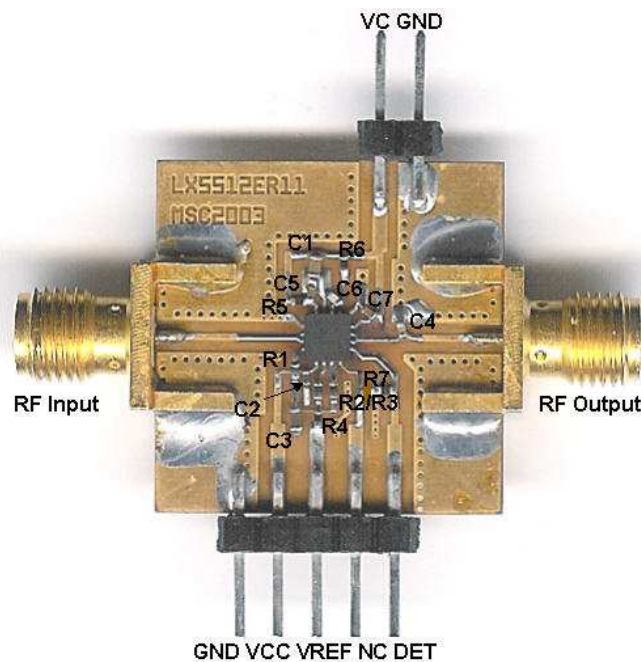
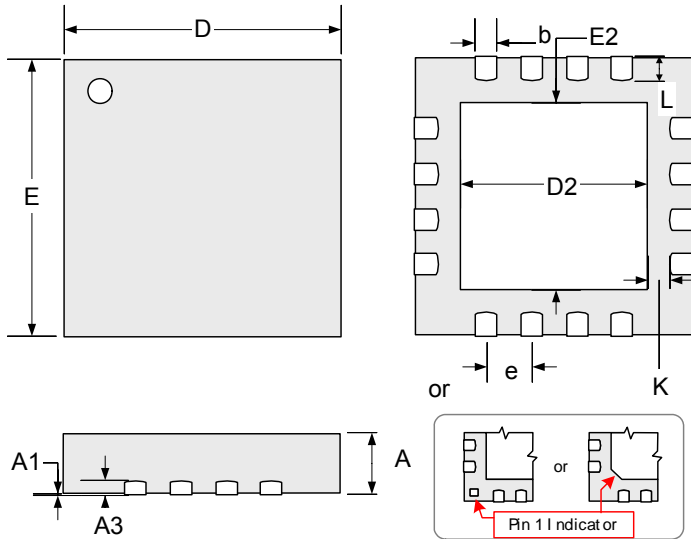


Figure 10 – Spectrum with 25dBm 11Mb/s CCK
($V_C = 5V$, $V_{ref} = 2.9V$, $I_{cq} = 55mA$, $I_C = 258mA$, Frequency = 2.45GHz)

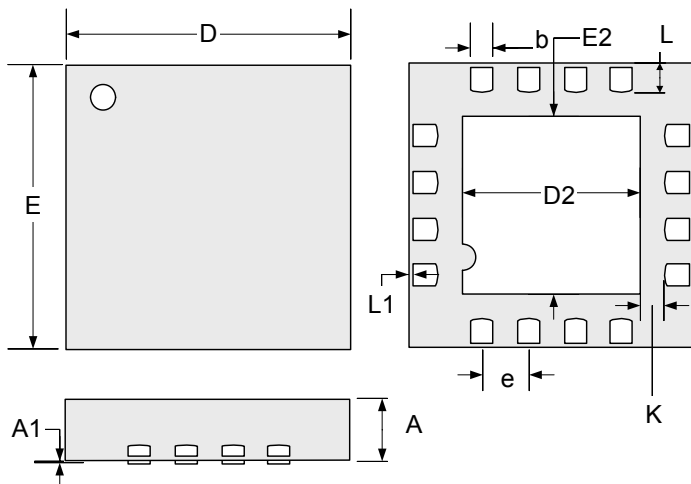
EVALUATION BOARD

Recommended BOM

Location	Value
C1,C3	1 uF (0603)
C2	10 nF(0402)
C4	2.2 pF (0402)
C5,C7	120 pF (0402)
C6	47 pF (0402)
R1,R2	50 Ω (0402)
R3	300 Ω (0402)
R4	100 Ω (0402)
R5	10 Ω (0402)
R6	5 Ω (0402)
R7	100 kΩ (0402)
TL1	120/10 mil (L/W)
TL2	30/10 mil (L/W)
TL3	70/10 mil (L/W)
Substrate	10 mil GETEK
	$\epsilon_r = 3.9, \tan \delta = 0.01$
	50Ω Microstrip width: 22 mil



PACKAGE DIMENSIONS
LQ 16-Pin MLPQ 3x3


Or



Dim	MILLIMETERS		INCHES	
	MIN	MAX	MIN	MAX
A	0.80	1.00	0.031	0.039
A1	0	0.05	0	0.002
A3	0.20 REF		0.008 REF	
b	0.18	0.30	0.007	0.012
D	3.00 BSC		0.118 BSC	
E	3.00 BSC		0.118 BSC	
e	0.50 BSC		0.020 BSC	
D2	1.30	1.55	0.051	0.061
E2	1.30	1.55	0.051	0.061
K	0.2	-	0.008	-
L	0.35	0.50	0.012	0.020
L1	-	0.15	-	0.006

Note:

- Dimensions do not include mold flash or protrusions; these shall not exceed 0.155mm(.006") on any side. Lead dimension shall not include solder coverage.
- Due to multiple qualified assembly sub-contractors either package (with different pin one indicators) may be shipped. Package type will be consistent within the smallest individual container.



Microsemi[®]

LX5512E

InGaP HBT 2.4 – 2.5 GHz Power Amplifier

PRODUCTION DATA SHEET

NOTES

PRODUCTION DATA – Information contained in this document is proprietary to Microsemi and is current as of publication date. This document may not be modified in any way without the express written consent of Microsemi. Product processing does not necessarily include testing of all parameters. Microsemi reserves the right to change the configuration and performance of the product and to discontinue product at any time.