

**DESCRIPTION**

The LX5561 is a low noise amplifier (LNA) for WLAN applications in the 2.4-2.5 GHz frequency range. This LNA is manufactured with an InGaAs Enhancement mode pseudomorphic HEMT (E-pHEMT) process.

It operates with a single positive voltage supply of 3.3V, with noise figure of 1.5dB while maintaining input third order intercept point(IIP3) of up to +6.5dBm.

The LNA is implemented with bias circuit and input/output matching circuit on chip, resulting in simple external circuit on board. In addition, the on-chip bias circuit provides stable performance of gain, NF and current for voltage variation compared to a general resistor-network bias circuit.

The LX5561 is available in a 12-pin 2mm x 2mm micro-lead package (MLPQ-12L).

**KEY FEATURES**

- 0.5µm InGaAs E-mode pHEMT
- 2.4 – 2.5GHz Operation
- Single 3.3V Supply
- Gain ~ 13.0dB
- Noise Figure ~ 1.5dB
- Input IP3 ~ +6.5dBm
- Input P1dB ~ +2.5dBm
- On-Chip Bias Circuit
- On-Chip Input/Output Match
- 2mm x 2mm MLPQ-12L
- Low Profile 0.5mm

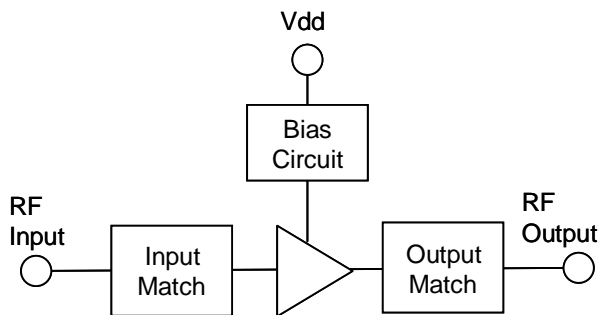
**BLOCK DIAGRAM**

**APPLICATIONS**

- Wireless LAN 802.11b/g
- WiMax

**IMPORTANT:** For the most current data, consult MICROSEMI's website: <http://www.microsemi.com>

**PRODUCT HIGHLIGHT**

**PACKAGE ORDER INFO**
**LL**

Plastic MLPQ

12 pin

RoHS Compliant / Pb-free

**LX5561LL**

Note: Available in Tape & Reel. Append the letters "TR" to the part number. (i.e. LX5561LL-TR)

**ABSOLUTE MAXIMUM RATINGS**

DC Supply Voltage, RF Off .....	4 V
Drain Current .....	40 mA
Total Power Dissipation .....	0.15 W
RF Input Power .....	+10 dBm
Operation Ambient Temperature .....	-40°C to +85°C
Storage Temperature Range .....	-65°C to 150°C
Package Peak Temp. for Solder Reflow (40 seconds maximum exposure)....	260°C (+0 -5)

Note: Exceeding these ratings could cause damage to the device. All voltages are with respect to Ground. Currents are positive into, negative out of specified terminal.

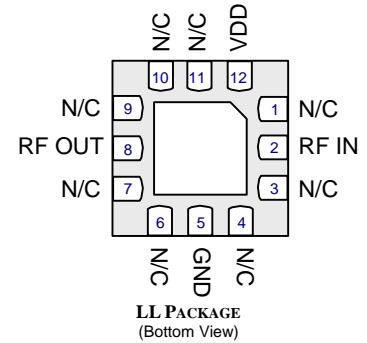
**PACKAGE PIN OUT**

RoHS / Pb-free NiPdAu Finish

**FUNCTIONAL PIN DESCRIPTION**

Name	Pin #	Description
RF IN	2	RF input for the low noise amplifier. This pin is AC-coupled and does not require a DC-blocking capacitor.
RF OUT	8	RF output for the low noise amplifier. This pin is AC-coupled and does not require a DC-blocking capacitor.
VDD	12	Supply voltage.
GND	5	Ground.
N/C	1,3,4,6,7,9,10,11, Center Metal	Not Connected. They can be treated either as open pins or connected to ground.

**ELECTRICAL CHARACTERISTICS**

 Test conditions:  $V_{DD} = 3.3V$ ,  $I_{DD} = 10.5mA$ ,  $T_A = +25^{\circ}C$  (Room Temperature)

Parameter	Symbol	Test Conditions	LX5561			Units
			Min	Typ	Max	
Application Frequency Range	f		2.4		2.5	GHz
Small-Signal Gain	S21			13.0		dB
Noise Figure	NF			1.5	1.8	dB
Input 3 <sup>rd</sup> Order Intercept Point	IIP3	Freq. 1 = 2.412GHz, Freq. 2 = 2.432GHz		6.5		dBm
Input P1dB	IP1dB	Freq. = 2.45GHz		2.5		dBm
Input Return Loss	S11			12		dB
Output Return Loss	S22			12		dB
Supply Voltage	$V_{DD}$			3.3		V
Supply Current	$I_{DD}$			10.5		mA

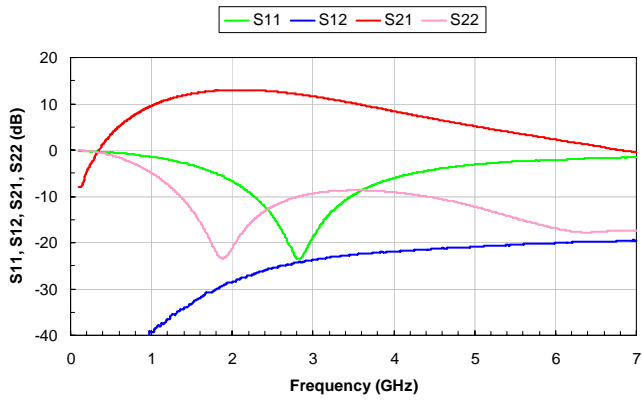
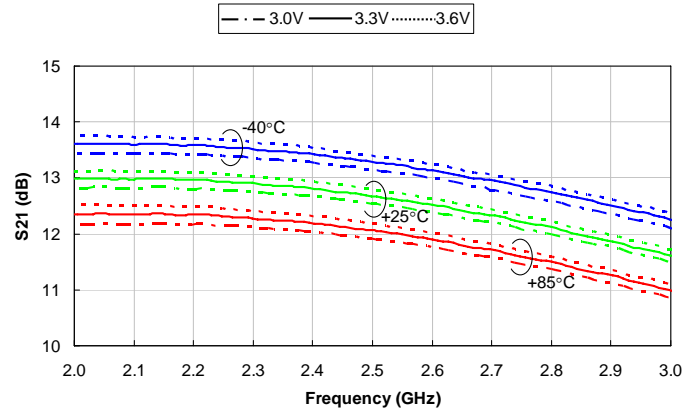
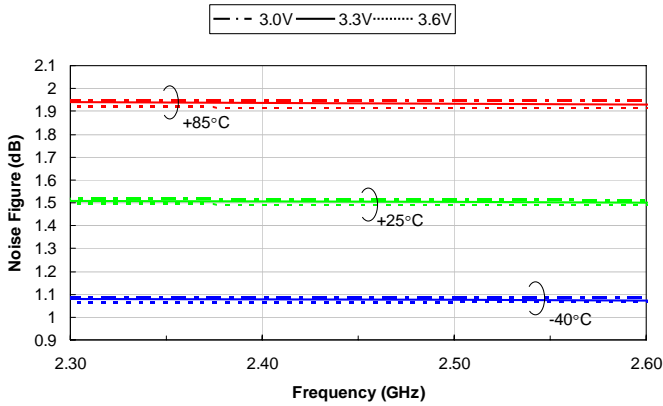
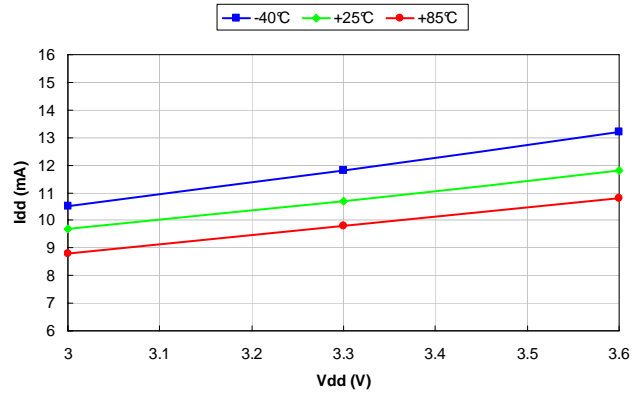
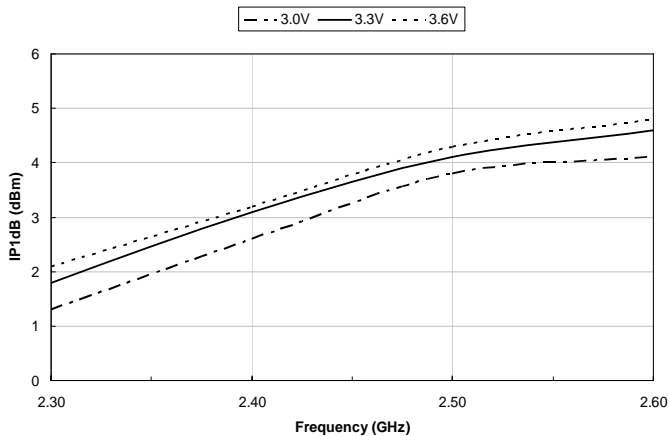
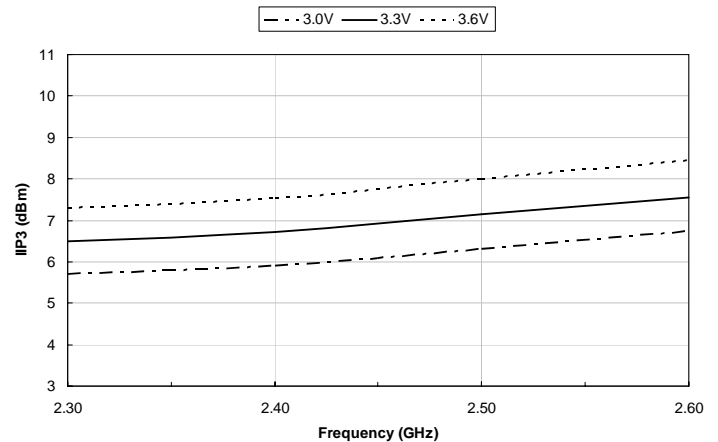
**S-PARAMETER**

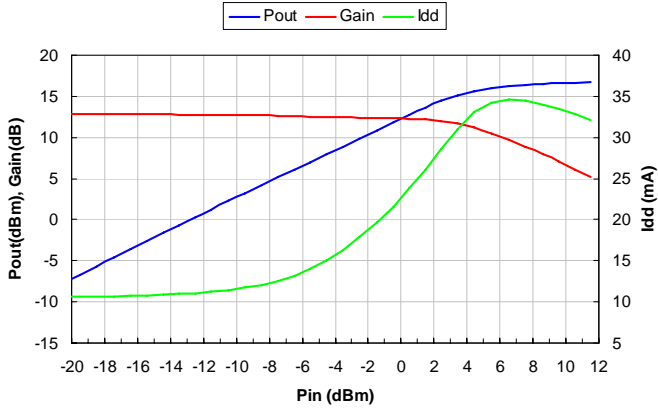
**GAIN OVER TEMP**

**NOISE FIGURE OVER TEMP**

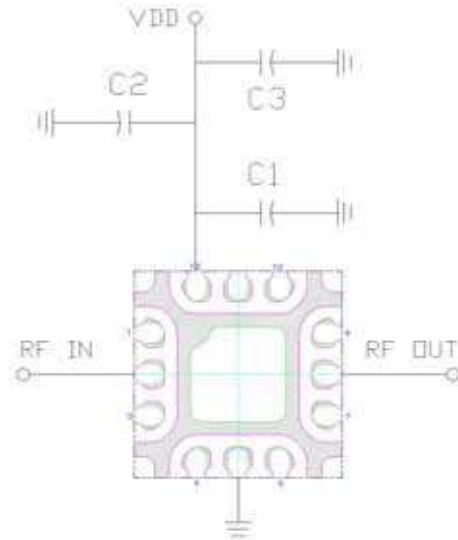
**CURRENT OVER TEMP**

**INPUT P1DB (+25°C)**

**INPUT IP3 (+25°C)**

**POWER SWEEP @ 2.45GHZ**

(Vdd=3.3V, Idq=10.5mA at Room Temperature)

**APPLICATION SCHEMATIC**

**BOM LIST**

Reference Designator	Part Description	Case
C1	Capacitor, 1 nF	0402
C2	Capacitor, 1 $\mu$ F	0603
C3	Capacitor, 10 $\mu$ F	0805

**NOTES**

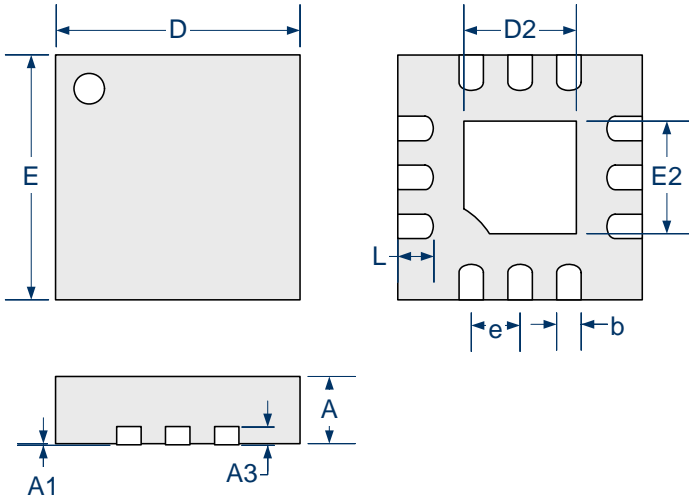
- It is recommended to place C1 at 20-50mil from MLP package outline.
- C2 and C3 are used for standalone evaluation board test only. They are not needed in final applications.

**PACKAGE DIMENSIONS**
**LL** 12-Pin MLPQ Plastic (2x2mm)

Dim	MILLIMETERS		INCHES	
	MIN	MAX	MIN	MAX
A	0.40	0.50	0.016	0.020
A1	0.00	0.05	0.000	0.002
A3	0.15 REF		0.006 REF	
b	0.15	0.25	0.006	0.010
D	2.00 BSC		0.079 BSC	
D2	0.77	1.02	0.030	0.040
E	2.00 BSC		0.079 BSC	
E2	0.77	1.02	0.030	0.040
e	0.40 BSC		0.016 BSC	
L	0.19	0.39	0.007	0.015

**Note:**

- Dimensions do not include mold flash or protrusions; these shall not exceed 0.155mm(.006") on any side. Lead dimension shall not include solder coverage.

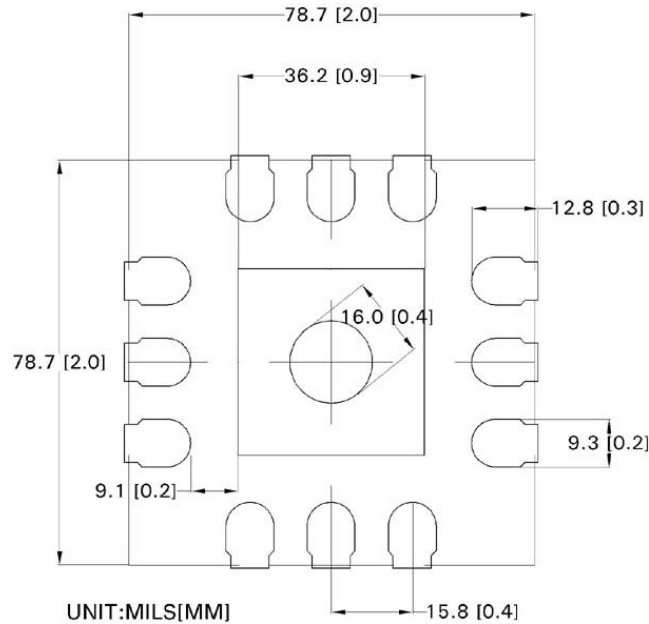

Recommended Land Pattern



**Microsemi**<sup>®</sup>

**LX5561**

**InGaAs – E-Mode pHEMT Low Noise Amplifier**

**PRODUCTION DATA SHEET**

**NOTES**

PRODUCTION DATA – Information contained in this document is proprietary to Microsemi and is current as of publication date. This document may not be modified in any way without the express written consent of Microsemi. Product processing does not necessarily include testing of all parameters. Microsemi reserves the right to change the configuration and performance of the product and to discontinue product at any time.

[www.Microsemi.COM](http://www.Microsemi.COM)

**NOTES**