



DESCRIPTION

The LX1699 is a high performance CCFL (Cold Cathode Fluorescent Lamp) controller optimized for wide input voltage range display backlighting applications.

The LX1699 brightness control architecture supports Intel's DPST (Display Power Saving Technology) that adjusts the brightness as a function of video content.

The controller includes a built-in reference voltage regulator so it can be operated directly from the battery without the need of an external 5V supply from the system.

The LX1699 power stage is full bridge driven and includes DC coupled high side drivers on chip for the external P-channel high side and N-channel low side power MOSFETs. Also for fixed input supply applications the IC may be used as a Direct Drive CCFL controller connected directly to the high voltage transformer primary via a single pair of N-FET drivers.

The LX1699 has improved lamp current accuracy, fully programmable lamp frequency and burst dimming frequency oscillators, and Microsemi's patented full-proof lamp strike circuitry.

Programmable open lamp strike timeout and open lamp, short lamp, and over voltage fault detection are fully implemented.

Reverse analog dimming control is provided to set the lamp current from maximum lamp current to max -1.8mArms range.

Digital Dimming duty cycle is controlled by providing either a DC voltage or a PWM signal to the BRITE_D pin. Burst frequency can be controlled by either by the on chip precision oscillator or directly by a logic signal at BRITE_D.

The LX1699 is available in the 20 pin 4 x 4mm QFN surface mount packages. Operating temperature ranges is -20°C ~ 70°C.

IMPORTANT: For the most current data, consult MICROSEMI's website: <http://www.microsemi.com>
Patents Pending

KEY FEATURES

- Microsemi Patented Direct Drive™ or Full Bridge Configurable
- 6.5 to 24 Volts Wide Input Voltage Range
- Supports Intel™ DPST for System PWM Input
- Compatible with Microsemi's New SMBus CCFL Controllers
- Fully Programmable Open Lamp and Load Fault Time Outs
- Detects and Shuts Down for all Common Lamp Faults
- On Chip Full Wave Rectifiers for Lamp Voltage and Current
- Uses Industry Standard High Voltage Transformers

APPLICATIONS

- Note Book LCD Displays
- Transportable Computers
- Web Tablet LCD displays

PRODUCT HIGHLIGHT

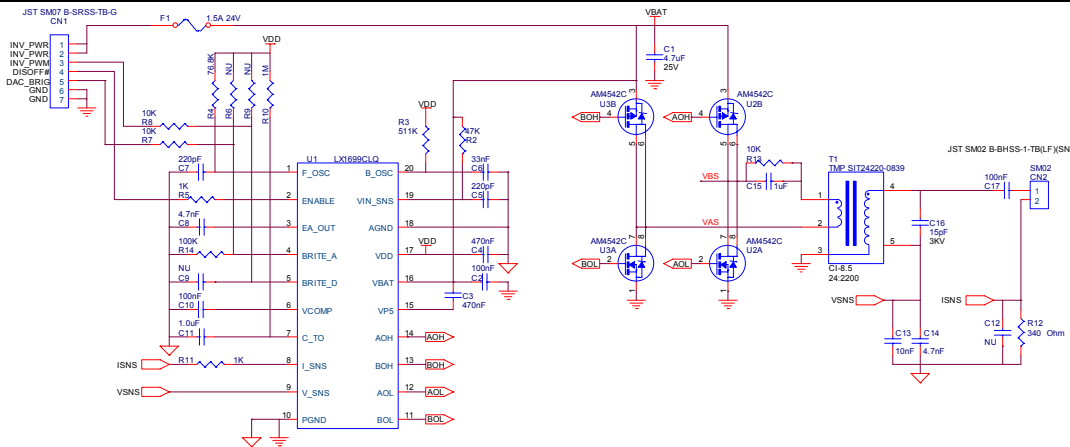

PACKAGE ORDER INFO

THERMAL DATA

T _A (°C)	LQ	Plastic 4x4 mm QFN 20-pin	θ_{JA} = 31 °C/W
-20 to 70		LX1699CLQ	Junction Temperature Calculation: T _J = T _A + (P _D × θ _{JA}). The θ _{JA} numbers are guidelines for the thermal performance of the device/pc-board system. All of the above assume no ambient airflow.
Note: Available in Tape & Reel. Append the letters "TR" to the part number. (i.e. LX1699CLQ-TR)			



Microsemi[®]

INFORMATION

Thank you for your interest in Microsemi[®] Analog Mixed Signal products.

The full data sheet for this device contains proprietary information.

To obtain a copy, please contact your local Microsemi sales representative. The name of your local representative can be obtained at the following link

<http://www.microsemi.com/contact/contactfind.asp>

or

Contact us directly by sending an email to:

IPGdatasheets@microsemi.com

Be sure to specify the data sheet you are requesting and include your company name and contact information and or vcard.

We look forward to hearing from you.