

DESCRIPTION

The LX1992 is a compact high efficiency step-up boost controller for driving white or color LEDs in backlight or frontlight systems and offers designers maximum flexibility with respect to efficiency and cost. The LX1992 features a pseudo-hysteretic pulse frequency modulation topology and uses an external N-Channel MOSFET. Further, the LX1992 features control circuitry that is optimized for portable systems (e.g., quiescent supply current of 80 μ A (typ) and a shutdown current of less than 1 μ A). These design enhancements provide for improved performance in battery operated systems applications.

The device input voltage range is from 1.6V to 6.0, allowing for a wide selection of system battery voltages and start-up operation is guaranteed at 1.6V input.

Programming the output current is readily achieved by using one external current sense resistor in series with the LEDs. In this configuration, LED current provides a feedback signal to the FB pin, maintaining constant current regardless of varying LED forward voltage (V_F). Moreover, the LX1992 is capable of achieving output currents in excess of 150mA, depending on the MOSFET selected.

The LX1992 has an additional feature for simple dynamic adjustment of the output current (i.e., up to 100% of the maximum programmed current). Designers can make this adjustment via an analog reference signal or a direct PWM generated signal applied to the ADJ pin and any PWM amplitude is easily accommodated with a single external resistor.

The LX1992 is available in both the 8-Pin MSOP, and the miniature 8-Pin MLP requiring minimal PCB area.

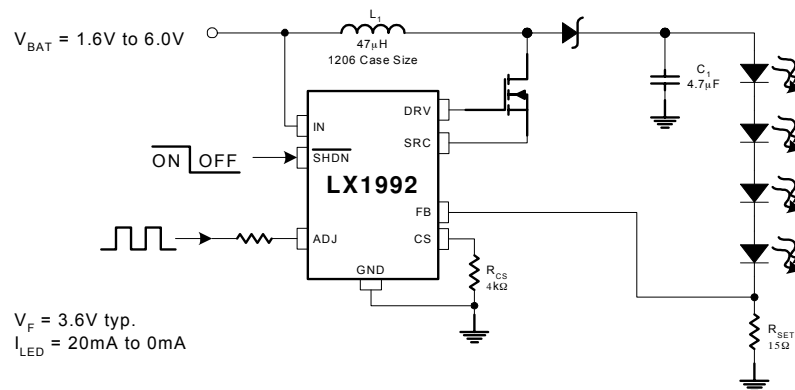
KEY FEATURES

- > 90% Efficiency
- 80 μ A Typical Quiescent Supply Current
- Externally Programmable Peak Inductor Current Limit For Maximum Efficiency
- Logic Controlled Shutdown
- < 1 μ A Shutdown Current
- Dynamic Output Current Adjustment Via Analog Reference Or Direct PWM Input
- 8-Pin MSOP Package or 8-Pin MLP

APPLICATIONS/BENEFITS

- Pagers
- Wireless Phones
- PDAs
- Handheld Computers
- General LCD Bias Applications
- LED Driver
- Digital Camera Displays

IMPORTANT: For the most current data, consult MICROSEMI's website: <http://www.microsemi.com>

PRODUCT HIGHLIGHT

PACKAGE ORDER INFO

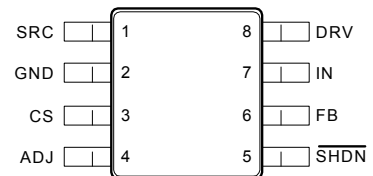
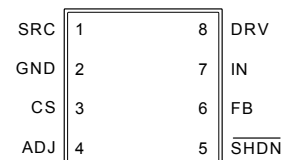
T_A (°C)	LM Plastic MLP 8-Pin	DU Plastic MSOP 8-Pin
	0 to 70	RoHS Compliant / Pb-free Transition DC: 0452 LX1992CLM

Note: Available in Tape & Reel. Append the letters "TR" to the part number. (i.e. LX1992CDU-TR)

ABSOLUTE MAXIMUM RATINGS

Supply Voltage (V_{IN})	-0.3V to 7.0V
Feedback Input Voltage (V_{FB})	-0.3V to $V_{IN} + 0.3V$
Shutdown Input Voltage (V_{SHDN})	-0.3V to $V_{IN} + 0.3V$
Analog Adjust Input Voltage (V_{ADJ})	-0.3V to $V_{IN} + 0.3V$
Source Input Current (I_{SRC})	0.80 A _{RMS}
Operating Junction Temperature	150°C
Storage Temperature Range	-65°C to 150°C
Lead Temperature (Soldering 180 seconds)	235°C
Peak Package Solder Reflow Temp. (40 second max. exposure)	260°C (+0, -5)

Note: Exceeding these ratings could cause damage to the device. All voltages are with respect to Ground. Currents are positive into, negative out of specified terminal.

PACKAGE PIN OUT

DU PACKAGE
(Top View)

LM PACKAGE
(Top View)

RoHS / Pb-free 100% Matte Tin Lead Finish

THERMAL DATA
DU Plastic MSOP 8-Pin

THERMAL RESISTANCE-JUNCTION TO AMBIENT, θ_{JA}	206°C/W
THERMAL RESISTANCE-JUNCTION TO CASE, θ_{JC}	39°C/W

LM Plastic MLP 8-Pin

THERMAL RESISTANCE-JUNCTION TO AMBIENT, θ_{JA}	41°C/W
THERMAL RESISTANCE-JUNCTION TO CASE, θ_{JC}	5.2°C/W

Junction Temperature Calculation: $T_J = T_A + (P_D \times \theta_{JC})$.

The θ_{JA} numbers are guidelines for the thermal performance of the device/pc-board system. All of the above assume no ambient airflow.

FUNCTIONAL PIN DESCRIPTION

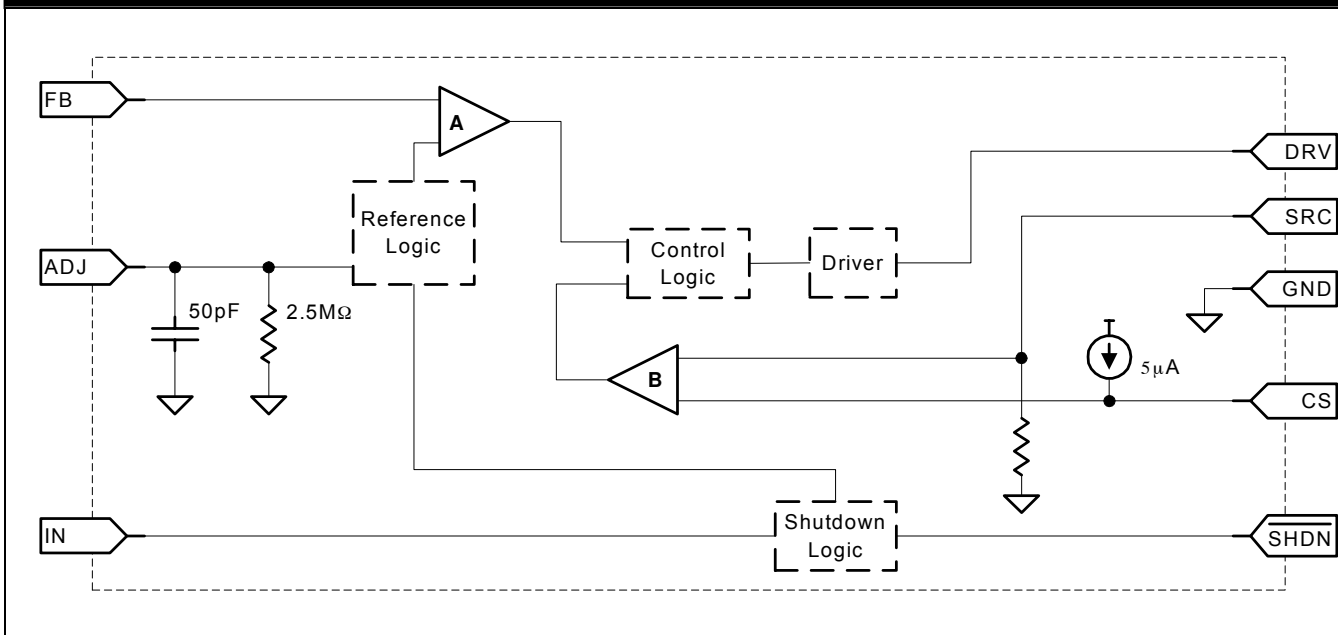
NAME	DESCRIPTION
IN	Unregulated IC Supply Voltage Input – Input range from +1.6V to 6.0V. Bypass with a 1 μ F or greater capacitor for operation below 2.0V.
FB	Feedback Input – Connects to a current sense resistor between the output load and GND to set the output current.
SHDN	Active-Low Shutdown Input – A logic low shuts down the device and reduces the supply current to 0.2 μ A (Typ). Connect SHDN to V_{CC} for normal operation.
DRV	MOSFET Gate Driver – Connects to an external N-Channel MOSFET.
CS	Current-Sense Amplifier Input – Connecting a resistor between CS and GND sets the peak inductor current limit.
GND	Common terminal for ground reference.
ADJ	Adjustment Signal Input – Provides the internal reference, via an internal filter and gain resistor, allowing a dynamic output current adjustment corresponding to a varying duty cycle. The actual ADJ pin voltage range is from V_{IN} to GND. In order to minimize the current sense resistor power dissipation a practical range of $V_{ADJ} = 0.0V$ to 0.5V should be used.
SRC	MOSFET Current Sense Input - Connects to the External N-Channel MOSFET Source.

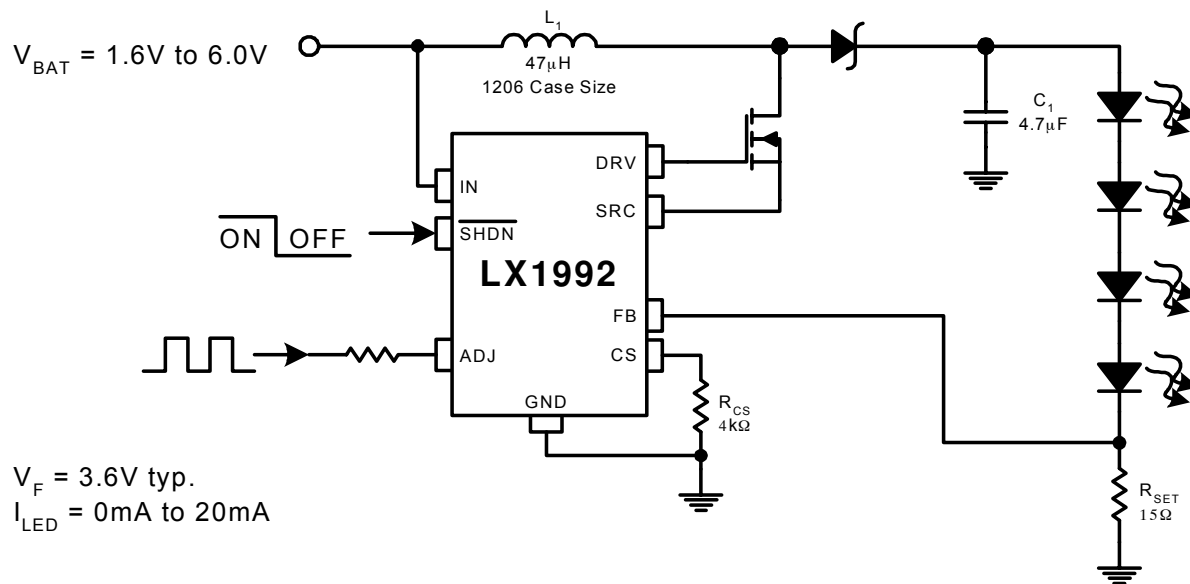
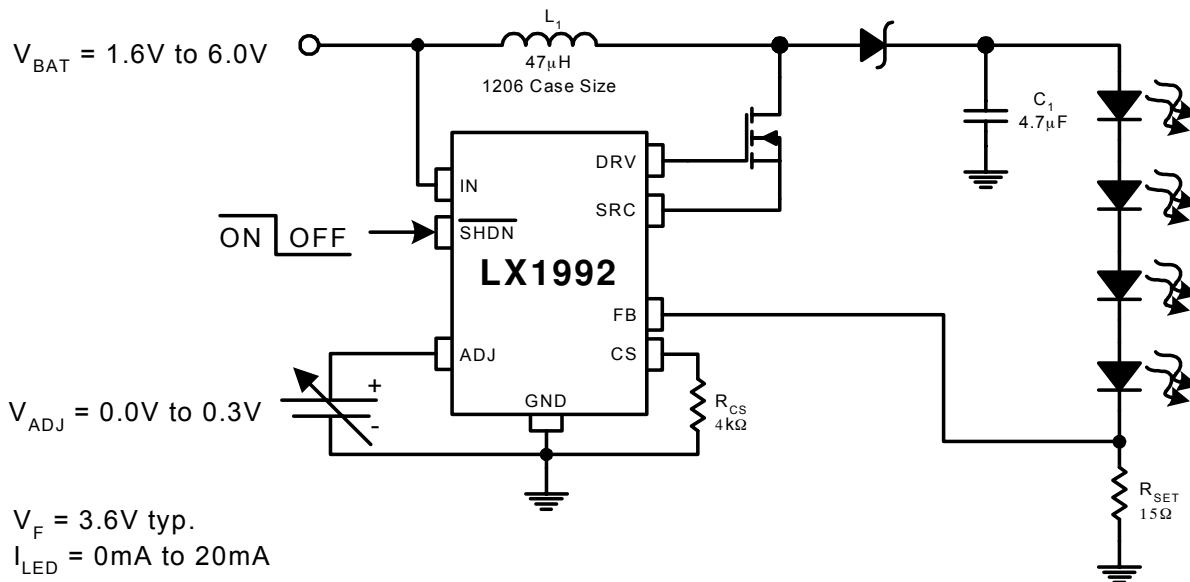
Note: ADJ pin should not be left floating.

ELECTRICAL CHARACTERISTICS

Unless otherwise specified, the following specifications apply over the operating ambient temperature $0^{\circ}\text{C} \leq T_A \leq 70^{\circ}\text{C}$ except where otherwise noted and the following test conditions: $V_{\text{IN}} = 3\text{V}$, $I_{\text{LOAD}} = 20\text{mA}$, $\text{SHDN} = V_{\text{IN}}$, and $V_{\text{ADJ}} = 300\text{mV}$.

Parameter	Symbol	Test Conditions	LX1992			Units
			Min	Typ	Max	
Operating Voltage	V_{IN}		1.6		6.0	V
Minimum Start-up Voltage	V_{SU}	$T_A = +25^{\circ}\text{C}$			1.6	V
Start-up Voltage Temperature Coefficient	k_{VST}			-2		mV/ $^{\circ}\text{C}$
Quiescent Current	I_{Q}	$V_{\text{FB}} > 0.3\text{V}$		50	100	μA
		$V_{\text{SHDN}} < 0.4\text{V}$		0.2	0.5	μA
FB Threshold Voltage	V_{FB}		275	300	325	mV
FB Input Bias Current	I_{FB}	$V_{\text{FB}} = 0.3\text{V}$	-100		100	nA
ADJ Input Voltage Range	V_{ADJ}	$I_{\text{OUT}} = (V_{\text{ADJ}})/(R_{\text{SET}})$	0.0		V_{IN}	V
ADJ Input Bias Current	I_{ADJ}	$V_{\text{ADJ}} < 0.3\text{V}$	-150		0	nA
Shutdown Input Bias Current	I_{SHDN}	$\text{SHDN} = \text{GND}$	-50		50	nA
Shutdown High Input Voltage	V_{SHDN}		1.6			V
Shutdown Low Input Voltage	V_{SHDN}				0.4	V
Current Sense Bias Current	I_{CS}	$V_{\text{FB}} < 0.3\text{V}$	3.0	5.0	7.0	μA
Minimum Peak Current	I_{MIN}	$R_{\text{CS}} = 560\Omega$	53		83	mA
Efficiency	η	$V_{\text{IN}} = 3.0\text{V}$, $I_{\text{LOAD}} = 20\text{mA}$		85		%
NDRV Sink Current	I_{SNK}	$V_{\text{IN}} = 5\text{V}$		50		mA
NDRV Source Current	I_{SRC}	$V_{\text{IN}} = 5\text{V}$		100		mA
Off-Time	t_{OFF}	$V_{\text{FB}} = 0.3\text{V}$; $V_{\text{ADJ}} = 0.5\text{V}$	100		500	ns

SIMPLIFIED BLOCK DIAGRAM


APPLICATION CIRCUITS
Typical LED Driver Applications

Figure 1 – LED Driver with Full-Range Dimming Via PWM Input

Figure 2 – LED Driver with Full-Range Dimming Via Analog Voltage Input

Note: The component values shown are only examples for a working system. Actual values will vary greatly depending on desired parameters, efficiency, and layout constraints.

APPLICATION INFORMATION
OPERATING THEORY

The LX1992 is a PFM boost converter that is optimized for driving a string of series connected LEDs. It operates in a pseudo-hysteretic mode with a fixed switch “off time” of 300ns. Converter switching is enabled as LED current decreases causing the voltage across R_{SET} to decrease to a value less than the voltage at the VADJ pin. When the voltage across R_{SET} (i.e., V_{FB}) is less than VADJ, comparator A activates the control logic. The control logic activates the DRV output circuit that connects to the gate of the external FET. The DRV output is switched “on” (and remains “on”) until the inductor current ramps up to the peak current level. This current level is set via the external R_{CS} resistor and monitored through the CS and SRC inputs by comparator B.

The LED load is powered from energy stored in the output capacitor during the inductor charging cycle. Once the peak inductor current value is achieved, the NDRV output is turned off (off-time is typically 300ns) allowing a portion of the energy stored in the inductor to be delivered to the load (e.g., see Figure 5, channel 2). This causes the output voltage to continue to rise across R_{SET} at the input to the feedback circuit. The LX1992 continues to switch until the voltage at the FB pin exceeds the control voltage at the ADJ pin.

The value of R_{SET} is established by dividing the maximum adjust voltage by the maximum series LED current. A minimum value of 15Ω is recommended for R_{SET} . The voltage at the FB pin is the product of I_{OUT} (i.e., the current through the LED chain) and R_{SET} .

$$R_{SET} = \left[\frac{V_{ADJmax}}{I_{LEDmax}} \right]$$

The application of an external voltage source at the ADJ pin provides for output current adjustment over the entire dimming range and the designer can select one of two possible methods. The first option is to connect a PWM logic signal to the ADJ pin (e.g., see Figure 1). The LX1992 includes an internal 50pF capacitor to ground that works with an external resistor to create a low-pass filter (i.e., filter out the AC component of a pulse width modulated input of $f_{PWM} \geq 100KHz$). The second option is to adjust the reference voltage directly at the ADJ pin by applying a DC voltage from 0.0 to 0.3V (e.g., see Figure 2). The adjustment voltage level is selectable (with limited accuracy) by implementing the voltage divider created between the external series resistor and the internal 2.5M Ω resistor. Disabling the LX1992 is achieved by driving the SHDN pin with a low-level logic signal thus reducing the device power consumption to less than 0.5 μA (typ).

INDUCTOR SELECTION AND OUTPUT CURRENT LIMIT PROGRAMMING

Setting the level of peak inductor current to approximately 2X the expected maximum DC input current will minimize the inductor size, the input ripple current, and the output ripple voltage. The designer is encouraged to use inductors that will not saturate at the peak inductor current level. An inductor value of 47 μH is recommended. Choosing a lower value emphasizes peak current overshoot while choosing a higher value emphasizes output ripple voltage. The peak switch current is defined using a resistor placed between the CS terminal and ground and the I_{PEAK} equation is:

$$I_{PEAK} = I_{MIN} + \left(\frac{V_{IN}}{L} \right) t_D + \left(\frac{I_{CS}}{R_{ICS}} \right) R_{CS}$$

The maximum I_{PEAK} value is limited by the I_{SRC} value (max. = 0.8 A_{RMS}). The minimum I_{PEAK} value is defined when R_{CS} is zero. The value range for parameters I_{MIN} and I_{CS} are provided in the ELECTRICAL CHARACTERISTICS section of this data sheet. The parameter t_D is related to internal operation of the device. A typical value at 25°C is 800ns. R_{ICS} is the internal current sense resistor connected to the SRC pin. A typical value at 25°C is 200m Ω . All of these parameters have an effect on the final I_{PEAK} value.

DESIGN EXAMPLE:

Determine I_{PEAK} where V_{IN} equals 3.0V and R_{CS} equals 4.02K Ω using nominal values for all other parameters.

$$I_{PEAK} = 73mA + \left(\frac{3.0V}{47\mu H} \right) \times 800ns + \left(\frac{5.0\mu A}{200m\Omega} \right) \times 4.02K\Omega$$

The result of this example yields a nominal I_{PEAK} of approximately 225mA.

OUTPUT RIPPLE AND CAPACITOR SELECTION

Output voltage ripple is a function of the inductor value (L), the output capacitor value (C_{OUT}), the peak switch current setting (I_{PEAK}), the load current (I_{OUT}), the input voltage (V_{IN}) and the output voltage (V_{OUT}) for a this boost converter regulation scheme. When the switch is first turned on, the peak-to-peak voltage ripple is a function of the output droop (as the inductor current charges to I_{PEAK}), the feedback transition error (i.e., typically 10mV), and the output overshoot (when the stored energy in the inductor is delivered to the load at the end of the charging cycle). Therefore the total ripple voltage is

$$V_{RIPPLE} = \Delta V_{DROOP} + \Delta V_{OVERSHOOT} + 10mV$$

The initial droop can be estimated as follows where the 0.5 value in the denominator is an estimate of the voltage drop across the inductor and the FET's R_{DS_ON} : The

APPLICATION INFORMATION

formula for ΔV_{DROOP} is:

$$\Delta V_{DROOP} = \frac{\left(\frac{L}{C_{OUT}}\right) \times (I_{PK} \times I_{OUT})}{(V_{IN} - 0.5)}$$

The output overshoot can be estimated as follows where the 0.5 value in the denominator is an estimate of the voltage drop across the diode:

$$\Delta V_{OVERSHOOT} = \frac{\frac{1}{2} \times \left(\frac{L}{C_{OUT}}\right) \times (I_{PK} - I_{OUT})^2}{(V_{OUT} + 0.5 - V_{IN})}$$

DESIGN EXAMPLE:

Determine the V_{RIPPLE} where I_{PK} equals 200mA, I_{OUT} equals 12.8mA, L equals 47 μ H, C_{OUT} equals 4.7 μ F, V_{IN} equals 3.0V, and V_{OUT} equals 13.0V:

$$\Delta V_{DROOP} = \frac{\left(\frac{47\mu H}{4.7\mu F}\right) \times (200mA \times 12.8mA)}{(3.0 - 0.5)} \approx 10.2mV$$

$$\Delta V_{OVERSHOOT} = \frac{\frac{1}{2} \times \left(\frac{47\mu H}{4.7\mu F}\right) \times (200mA - 12.8mA)^2}{(13.0 + 0.5 - 3.0)} \approx 18.4mV$$

Therefore, $V_{RIPPLE} = 10.2mV + 18.4mV + 10mV = 38.6mV$

DIODE SELECTION

A Schottky diode is recommended for most applications (e.g. Microsemi UPS5817). The low forward voltage drop and fast recovery time associated with this device supports the switching demands associated with this circuit topology. The designer is encouraged to consider the diode's average and peak current ratings with respect to the application's output and peak inductor current requirements. Further, the diode's reverse breakdown voltage characteristic must be capable of withstanding a negative voltage transition that is greater than V_{OUT} .

TRANSISTOR SELECTION

The LX1992 can source up to 100mA of gate current. An N-channel MOSFET with a relatively low threshold voltage, low gate charge and low $R_{DS(ON)}$ is required to optimize overall circuit performance. The LX1992 Evaluation Board uses a Fairchild FDV303. This NMOS device was chosen because it demonstrates an $R_{DS,ON}$ of 0.33 Ω and a total gate charge Q_g of 1.64nC (typ.)

PCB LAYOUT

The LX1992 produces high slew-rate voltage and current waveforms hence; the designer should take this into consideration when laying out the circuit. Minimizing trace lengths from the IC to the inductor, transistor, diode, input and output capacitors, and feedback connection (i.e., pin 6) are typical considerations. Moreover, the designer should maximize the DC input and output trace widths to accommodate peak current levels associated with this topology.

EVALUATION BOARD

The LX1992 evaluation board is available from Microsemi for assessing overall circuit performance. The evaluation board, shown in Figure 3, is 3 by 3 inches (i.e., 7.6 by 7.6cm) square and programmed to drive 4 LEDs (provided). Designers can easily modify circuit parameters to suit their particular application by replacing R_{CS} (as described in this section) R_{SET} (i.e., R4) and diode load. Moreover, the inductor, FET, and switching diode are easily swapped out to promote design verification of a circuit that maximizes efficiency and minimizes cost for a specific application. The evaluation board input and output connections are described in Table 1.

The DC input voltage is applied to VBAT (not VCC) however the LX1992 IC may be driven from a separate DC source via the VCC input. The output current (i.e., LED brightness) is controlled by adjusting the on-board potentiometer. The designer may elect to drive the brightness adjustment circuit from VBAT or via a separate voltage source by selecting the appropriate jumper position (see Table 2). Optional external adjustment of the output LED current is achieved by disengaging the potentiometer and applying either a DC voltage or a PWM-type signal to the VADJ input. The PWM signal frequency should be higher than 150KHz and contain a DC component less than 350mV.

The LX1992 exhibits a low quiescent current ($I_Q < 0.5\mu A$: typ) during shutdown mode. The SHDN pin is used to exercise the shutdown function on the evaluation board. This pin is pulled-up to VCC via a 10K Ω resistor. Grounding the SHDN pin shuts down the IC (not the circuit output). The output voltage (i.e., voltage across the LED string) is readily measured at the VOUT terminal and LED current is derived from measuring the voltage at the VFDBK pin and dividing this value by 15 Ω (i.e., R4).

The factory installed component list for this must-have design tool is provided in Table 3 and the schematic is shown in Figure 4

APPLICATION INFORMATION (CONTINUED)

Figure 5: LX1992 Engineering Evaluation Board
Table 1: Input and Output Pin Assignments

Pin Name	Allowable Range	Description
VBAT	0 to 6V	Main power supply for output. (Set external current limit to 0.5A)
VCC	1.6V to 6V	LX1992 power. May be strapped to VBAT or use a separate supply if VCC jumper is in the SEP position. Do not power output from VCC pin on board..
VPOT	1.6V to 6V	Potentiometer power. May be strapped to VBAT or use a separate supply if VPOT jumper is in the SEP position. Do not power output from VPOT pin on board.
VADJ IN	0 to 350mV	Apply a DC voltage or a PWM voltage to this pin to adjust the LED current. PWM inputs should be greater than 120Hz and DC portion less than 350mV.
/SHDN	0 to VCC	Pulled up to VCC on board (10KΩ), Ground to inhibit the LX1992.
VOUT	0 to 18V	Power supply output voltage that is applied to LED string.
VFDBK	0 to 400mv	Sense resistor voltage. Divide this voltage by 15 to determine LED current.

Table 2: Jumper Pin Position Assignments

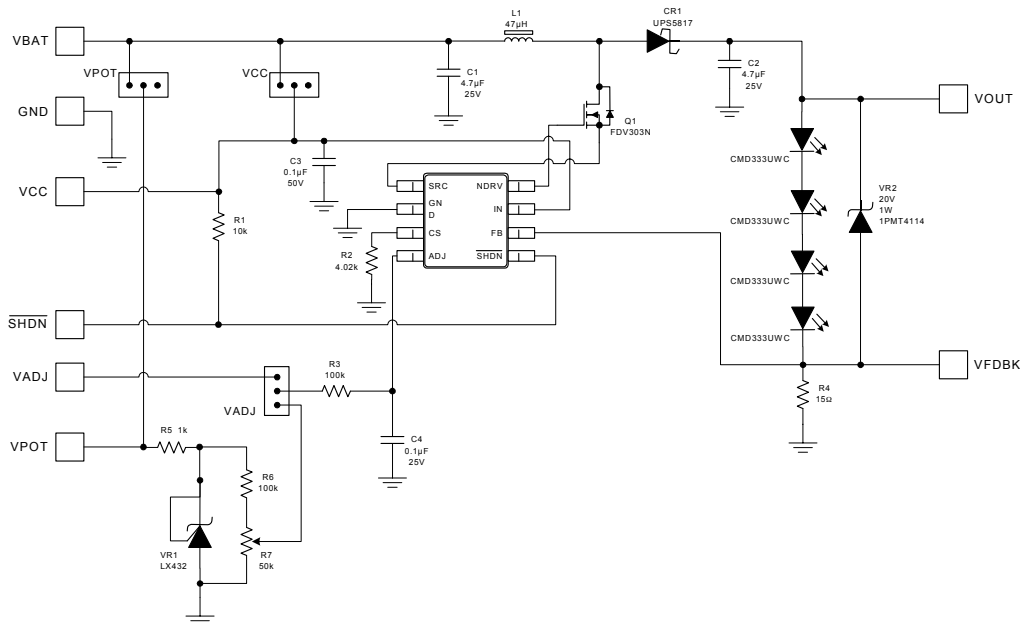
Jumper Position	Functional Description
VCC/ BAT	Use this position when powering VBAT and VCC from the same supply. Do not connect power to the VCC input when using this jumper position.
VCC/ SEP	Use this position when using a separate VCC supply (different from VBAT).
VPOT/ VBAT	Use this position when powering the potentiometer reference circuit from the VBAT supply. Do not connect power to the VCC input when using this jumper position.
VPOT/ SEP	Use this position when using a separate power supply (different from VBAT) to power the potentiometer reference circuit. This will lower the VBAT current and provide a more accurate efficiency reading for the LX1992 circuit.
ADJ/ POT	Use this position when using the potentiometer to adjust LED current.
ADJ/ EXT	Use this position when adjusting the LED current with an external PWM that has a repetition rate >120Hz. Or when using a DC adjustment voltage.

Note: Always put jumpers in one of the two possible positions

APPLICATION INFORMATION (CONTINUED)
Table 3: Factory Installed Component List for the LX1992 Evaluation Board

Quantity	Part Reference	Description	Manufacturer	Part Number
1	Q1	Mosfet, N-Channel, 25V, SOT23 Type SMT	Fairchild	FDV303N
1	CR1	Rectifier, Schottky, 1A, 20V, Powermite Type SMT	Microsemi	UPS5817
1	L1	Inductor, 47uH, 540mA, SMT	Toko	A920CY-470
2	C1, C2	Capacitor, Ceramic X5R, 4.7uF, 25V, 1210 Type SMT	Taiyo Yuden	CETMK325BJ475MN
2	C3, C4	Capacitor, Ceramic X7R, 0.1uF, 50V, 0805 Type SMT	Murata	GRM40X7R104M050
1	R4	Resistor, 15 Ohm, 1/10W, 0805 Type SMT	Panasonic	ERJ6ENF15R0
1	R5	Resistor, 1K, 1/16W, 0603 Type SMT	Panasonic	ERJ3EKF1001
1	R2	Resistor, 4.02K, 1/16W, 0603 Type SMT	Panasonic	ERJ3EKF4021
2	R3, R6	Resistor, 100K, 1/16W, 0603 Type SMT	Panasonic	ERJ3EKF1003
1	R1	Resistor, 10K, 1/16W, 0603 Type SMT	Panasonic	ERJ3EKF1002
1	R7	Trimpot, 50K, 1/2W, Through Hole Type	Bourns	3352E-1-503
1	VR1	IC, Voltage Reference, 1.25 Volts, SOT23 Type SMT	Microsemi	LX432CSC
1	VR2	Diode, Zener, 24V, 3W Powermite Type SMT	Microsemi	1PMT5934B
4	LED1 - 4	White LED	Chicago Miniature	CMD333UWC
3	JB1 - JB3	Header, 3 Pos Vertical Type	3M	929647-09-36
3		Jumper	3M	929955-06

Note: The minimum set of parts needed to build a working power supply are: Q1, CR1, L1, C2, C3, R2, R4, U1.


Figure 4 – LX1992 Boost Evaluation Board Schematic

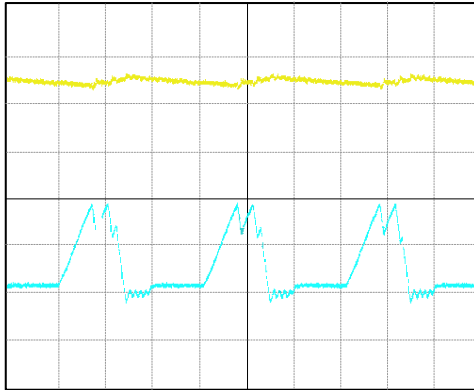
CHARACTERISTIC CURVES


Figure 5: V_{OUT} and Inductor Current Waveforms.
 Channel 1: V_{OUT} (AC coupled; 200mV/div)
 Channel 2: Inductor Current (100mA/div.)
 Configuration: $V_{IN} = 3.0V$, $V_{OUT} = 13.0V$, $I_{IN} = 65mA$

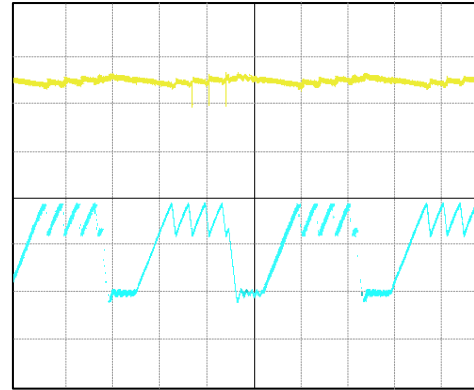


Figure 6: V_{OUT} and Inductor Current Waveforms.
 Channel 1: V_{OUT} (AC coupled; 100mV/div)
 Channel 2: Inductor Current (100mA/div.)
 Configuration: $V_{IN} = 3.0V$, $V_{OUT} = 13.7V$, $I_{IN} = 120mA$

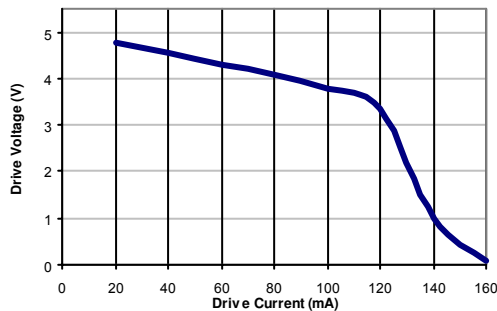


Figure 7: Gate Drive Voltage vs. Drive Current at $T = 25^{\circ}C$.

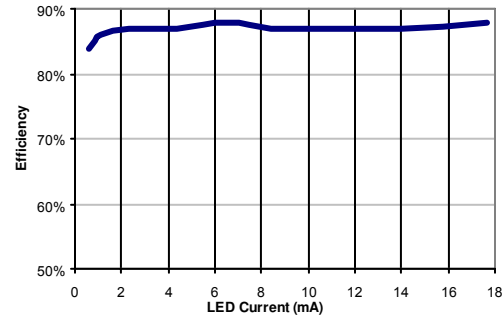


Figure 8: Efficiency vs. LED Output Current.
 Configuration: $V_{IN} = 3.0V$, $L = 47\mu H$, $R_{CS} = 4K\Omega$
 Note: Data taken from LXE1992 Evaluation Board

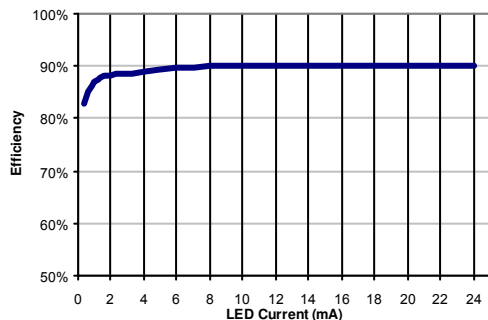
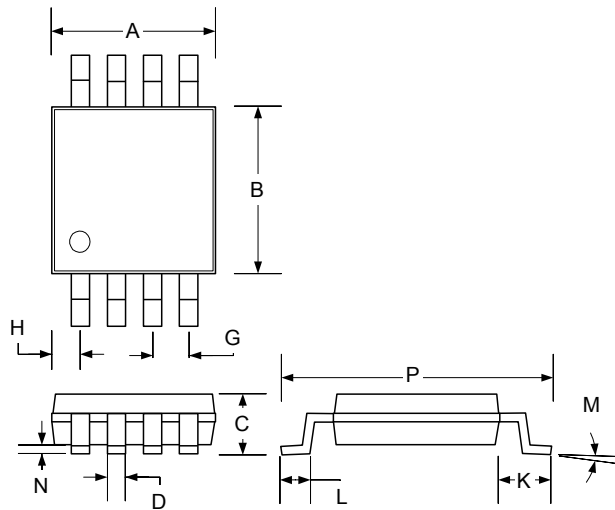
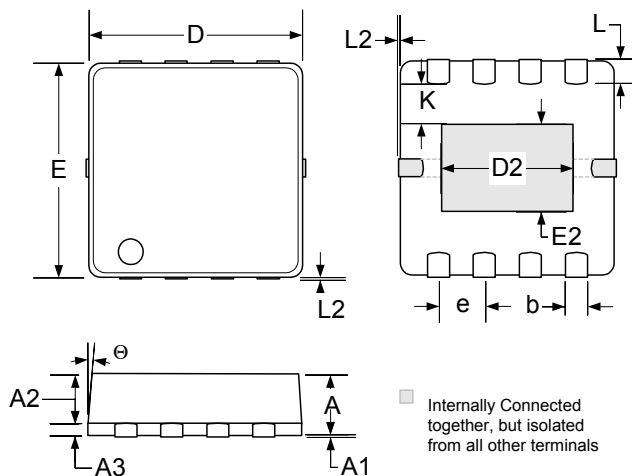


Figure 9: Efficiency vs. LED Output Current.
 Configuration: $V_{IN} = 5.0V$, $L = 47\mu H$, $R_{CS} = 4K\Omega$
 Note: Data taken from LXE1992 Evaluation Board

Efficiency Measurement Hint: When doing an efficiency evaluation using the LX1992 Evaluation Board, VPOT should be driven by a separate voltage supply to account for losses associated with the onboard reference (i.e., the 1.25V shunt regulator and 1K Ω resistor). This circuit will have $V_{BAT} - 1.25V$ across it and at the higher input voltages the 1K Ω resistor could have as much as 4mA through it. This shunt regulator circuitry will adversely effect the overall efficiency measurement and is not normally used in an application. Therefore it should not be considered when measuring efficiency.

PACKAGE DIMENSIONS
DU 8-Pin Miniature Shrink Outline Package (MSOP)


Dim	MILLIMETERS		INCHES	
	MIN	MAX	MIN	MAX
A	2.85	3.05	.112	.120
B	2.90	3.10	.114	.122
C	–	1.10	–	0.043
D	0.25	0.40	0.009	0.160
G	0.65 BSC		0.025 BSC	
H	0.38	0.64	0.015	0.025
J	0.13	0.18	0.005	0.007
K	0.95 BSC		0.037 BSC	
L	0.40	0.70	0.016	0.027
M	3°		3°	
N	0.05	0.15	0.002	0.006
P	4.75	5.05	0.187	0.198

LM 8-Pin Plastic MLP-Micro Exposed Pad


Dim	MILLIMETERS		INCHES	
	MIN	MAX	MIN	MAX
A	0.80	1.00	0.031	0.039
A1	0.00	0.05	0.000	0.002
A2	0.65	0.75	0.025	0.029
A3	0.15	0.25	0.005	0.009
b	0.28	0.38	0.011	0.015
D	2.90	3.10	0.114	0.122
E	2.90	3.10	0.114	0.122
e	0.65 BSC		0.025 BSC	
D2	1.52	2.08	0.060	0.082
E2	1.02	1.31	0.040	0.052
K	0.20	*	0.008	*
L	0.20	0.60	0.008	0.023
L2	0	0.13	0	0.005
Θ	0°	12°	0°	12°

Note:

- Dimensions do not include mold flash or protrusions; these shall not exceed 0.155mm(.006") on any side. Lead dimension shall not include solder coverage.



Microsemi[®]

LX1992

High Efficiency LED Driver

PRODUCTION DATA SHEET

NOTES

PRODUCTION DATA – Information contained in this document is proprietary to Microsemi and is current as of publication date. This document may not be modified in any way without the express written consent of Microsemi. Product processing does not necessarily include testing of all parameters. Microsemi reserves the right to change the configuration and performance of the product and to discontinue product at any time.