

DESCRIPTION

Microsemi's LX1994 is a compact, high efficiency, step-up boost controller which is designed to drive a string of white or colored LED's in a backlight or front light system. The LX1994 design is based on a dual mode PFM architecture and provides maximum typical efficiency greater than 92%.

The LX1994 has many unique design features and advantages over competitor solutions. The features included: low quiescent current (100 μ A typical), low shut down current (<1 μ A), dedicate ambient light sensor interface (LX1970), dual dimming modes, low voltage and low offset current sense, and integrated OVP protection.

The converter achieves high efficiency, low cost, and flexible design by selection of an external N-Channel MOSFET, current sense resistors, and integrated OVP protection.

IMPORTANT: For the most current data, consult MICROSEMI's website: <http://www.microsemi.com>
Patent Pending

The use of external N-channel MOSFET allows design to optimize system efficiency.

The OVP protection comparator eliminates the need of an external Zener diode clamp. The OVP function can be scaled for any output voltage. Maximum output current is achievable by selection of the current sense resistor. These features make the controller ideal for PDA or digital camera applications

To enhance system battery life, the LX1994 provides 2 dimming options and a dedicated ambient light sensor (LX1970) interface.

The LX1994 supports a wide range of system battery voltage inputs which ranges from 2.0 to 5.5V. The LX1994 is guaranteed to start up at 2.0V input. The LX1994 is available in miniature 10-pin MLP or MSOP packages.

KEY FEATURES

- Efficiency > 92%
- Dual PFM Architecture To Extend Battery Life
- V_{IN} Range 2.0V To 5.5V. Start Up Warranty @ 2.0V
- Logic Control Shutdown
- 100 μ A Typical Quiescent Current
- Shutdown I_Q Current <1 μ A
- OVP For Open String Output Voltage
- Low Voltage And Offset Current Sense
- Light Sensor (LX1970) interface
- Dual Dimming Options (PWM or DC Voltage)
- No External Zener Clamp Diode
- 10-Pin MLP or MSOP

APPLICATIONS

- Pagers
- PDA
- Cell Phone
- Portable Display
- Digital Cameras

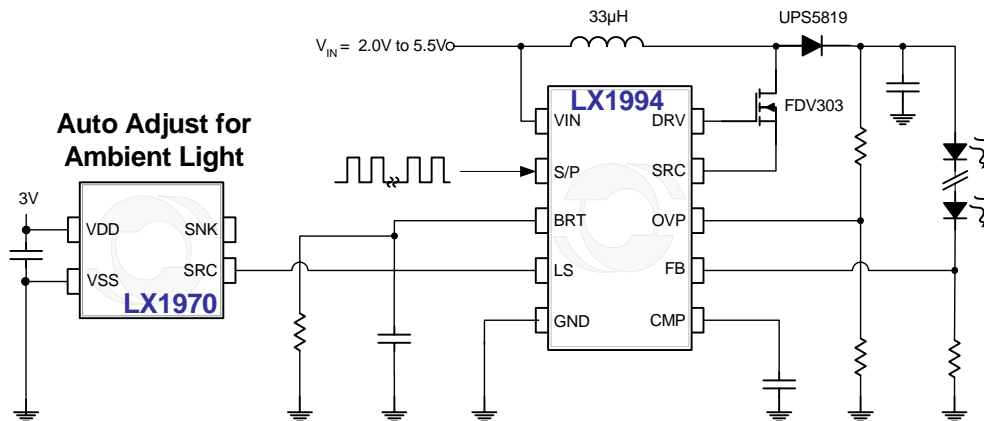
PRODUCT HIGHLIGHT

PACKAGE ORDER INFO

T _A (°C)	LD	Plastic MLP 10-Pin	DU	Plastic MSOP 10-Pin
	-40 to 85		RoHS Compliant / Pb-free LX1994CLD	

Note: Available in Tape & Reel. Append the letters "TR" to the part number. (i.e. LX1994CDU-TR)

ABSOLUTE MAXIMUM RATINGS

Supply Input Voltage (IN)	-0.3V to 7V
All Input Pins	-0.3V to V_{IN}
SRC Input Current	600mA
Operating Temperature Range	-40°C to 85°C
Maximum Operating Junction Temperature	150°C
Storage Temperature Range	-65°C to 150°C
Lead Temperature (Soldering 10 seconds)	235°C
Peak Package Solder Reflow Temp (40 seconds max. exposure)	260°C (+0, -5)

Note: Exceeding these ratings could cause damage to the device. All voltages are with respect to Ground. Currents are positive into, negative out of specified terminal.

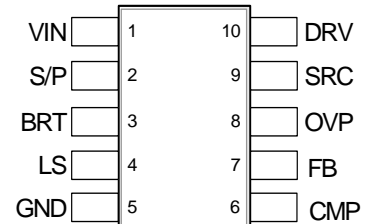
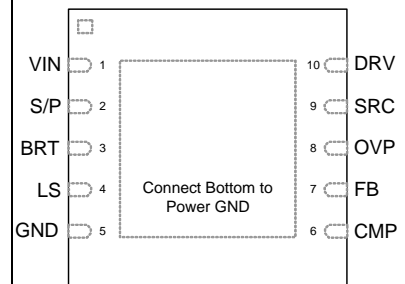
PACKAGE PIN OUT

DU PACKAGE
(Top View)

LD PACKAGE
(Top View)

RoHS / Pb-free 100% Matte Tin Lead Finish

THERMAL DATA
DU Plastic MSOP 10-Pin

THERMAL RESISTANCE-JUNCTION TO AMBIENT, θ_{JA}	113°C/W
---	---------

LD Plastic MLP 10-Pin

THERMAL RESISTANCE-JUNCTION TO AMBIENT, θ_{JA}	49°C/W
---	--------

Junction Temperature Calculation: $T_J = T_A + (P_D \times \theta_{JA})$.

The θ_{JA} numbers are guidelines for the thermal performance of the device/pc-board system. All of the above assume no ambient airflow.

FUNCTIONAL PIN DESCRIPTION

Name	Description
IN	Unregulated IC Supply Voltage Input – Input range from 2.0V to 5.5V. Bypass with a 1 μ F or greater capacitor for operation below 2.0V.
GND	Common terminal for ground reference.
BRT	LED Current Adjustment - Accepts a DC analog input.
FB	LED Current Sense – Connect to current sense resistor.
SRC	MOSFET Current Sense Input - Connects to the external N-Channel MOSFET source.
DRV	MOSFET Gate Driver – Connects to an external N-Channel MOSFET gate.
OVP	Over Voltage Programming Pin – Connects to a resistor divider between the output load and GND to set the maximum output voltage.
LS	Light Sensor Input – Allows light sensor current input to be modulated by the PWM control causing LED brightness to be a product of the PWM duty cycle and ambient light level.
CMP	Compensation Pin – Apply a 0.1 μ F capacitor for loop compensation.
S/P	Shutdown/PWM Pin – A logic low longer than 100 μ s causes the IC to enter Shutdown mode. Applying a PWM signal to this pin and a filter capacitor to the BRT pin allows amplitude independent PWM control.

ELECTRICAL CHARACTERISTICS

Unless otherwise specified, the following specifications apply over the operating ambient temperature $-40^{\circ}\text{C} \leq T_A \leq 85^{\circ}\text{C}$ except where otherwise noted and the following test conditions: $V_{IN} = 3.6\text{V}$, $I_{LOAD} = 20\text{mA}$

Parameter	Symbol	Test Conditions	LX1994			Units
			Min	Typ	Max	
Operating Voltage	V_{IN}		2.0		5.5	V
Minimum Start-up Voltage		$T_A = +25^{\circ}\text{C}$			2.0	V
Start-up Voltage Temperature Coefficient		For Reference Only		-2		mV/ $^{\circ}\text{C}$
Quiescent Current	I_Q	SHDN = V_{IN} , No external FET		100	200	μA
		SHDN = GND		0.35	1	μA
BRT Full scale bias current	IBRT	S/P = V_{IN} , VBRT = GND, ILS = 0A	7.5	10.5	13.5	μA
BRT Light sensor current	IBRT	S/P = V_{IN} , VBRT = GND, ILS = 100 μA		110		μA
S/P Logic Low Voltage	$V_{S/P}$				0.6	V
S/P Logic High Voltage	$V_{S/P}$		1.4			V
S/P Input DC Bias Current		S/P = V_{IN}	-1	0.05	1	μA
S/P PWM frequency			10		1000	KHz
S/P Pulse Width			50			ns
BRT PWM Voltage	VBRT	VS/P = V_{IN} (DCS/P = 100%)	270	300	330	mV
BRT PWM Voltage	VBRT	DCS/P = 50%, FPWM = 100KHZ		150		mV
Feedback Comparator Offset	VOS	VFB – VBRT, VBRT = 0mV		4		mV
SCR peak current	IPK	HYST mode; $T_A = +25^{\circ}\text{C}$	180	240	300	mA
Efficiency	η	VOU = 18V, $I_{LOAD} = 20\text{mA}$, $V_{IN} = 5.0\text{V}$		92		%
DRV Sink/Source Current			140	200		mA
Maximum Switch On-Time	t_{ON}		10	15	20	μs
Minimum Switch Off-Time	t_{OFF}		240	350	460	ns
OVP Threshold Voltage	V_{OVP}		1.10	1.22	1.34	V
OVP Input Bias Current	I_{OVP}	$V_{OVP} = 1\text{V}$	-50		50	nA

THEORY OF OPERATION**Basic PFM operation**

The LX1994 dual mode PFM modulator is implemented in two switching modes: the hysteretic and Continuous Switching Mode (CSM).

In *hysteretic switching mode*, the basic PFM modulator logic/timing block uses a Fixed Peak Current/ Fixed Off Time where the switch turns on and allows the inductor current to ramp to a finite peak level then shuts off for a fixed duration of time. The basic modulation cycle repeats as long as the converter output voltage is less than the maximum regulation level. When the maximum regulation level is reached, the switch remains off until the output voltage capacitor discharges to a level less than the minimum regulation level. The input signals to the switch logic block are the burst on/off control signal and the peak current detection signals. For low and negligible switch conduction losses the designer may set the peak current comparator at 20mV corresponding to 200mA of output current.

In *Continuous Switching Mode (CSM)*, the level to the peak current comparator is variable. This current level is developed by integrating the output of the feedback comparator which functions as a high gain bandwidth limited error amplifier. This current is clamped to the peak switch current limit of 600mA. The integrated capacitor is attached at the CMP pin when the burst on/off control line is forced to the "ON" state.

The conversion from hysteretic to CSM mode is performed when the burst length exceeds more than 16 switching cycles counting by an internal 16 bits shift register. The internal register is clocked by the switch transitions during each burst period. When the switching cycles exceed 16 cycles, the converter automatically switches over to CSM mode. CSM mode switching is latched by a J/K flip-flop. The conversion from CSM mode to hysteretic mode is performed when the error amplifier output falls below 10mV (corresponding to 100mA peak current) as determined by a comparator. This resets the J/K flip-flop and converts back to hysteric mode.

The LX1994 is a highly efficient PFM boost converter; its design is based on dual mode PFM for driving a series of white or color LEDs. The advantage of PFM switching is to minimize system efficiency losses in both heavy and light load operations. The LX1994 does not require an external oscillator due to PFM dual modes switching.

In light load operation, the converter minimizes switching losses by delivering more energy than necessary during switching burst period than the inactivity coast period.

In heavy load condition, the converter uses the Continuous Switching Current Mode (CSM) regulation scheme. This minimized peak switching current and thereby minimizes the conduction losses.

Losses

There are two types of losses in PFM regulator design: the switching loss, and conduction loss; that contribute to system inefficiency.

Switching loss: Energy switching losses are associated with a NFET's switch changing state (from on to off or vice versa) as a simultaneous high level of voltage and current are at the NFET's switch during the transition. This switching loss is proportional to the switching frequency.

Conduction loss: the loss due to current flow in the series resistance of the switch, inductor, and current sense resistor. Conduction loss is proportional to the square of the switch current.

Output Current Selection

The LED output current is regulated by adjusting of the FB pin voltage. If the FB pin voltage equals the BRT pin voltage, the LED current is the result of the FB pin voltage divided by the selected current sense resistor.

For example: in a 100% duty cycle design, FB pin voltage is 300mV, the current sense resistor is 15Ω. The LED current equals:

$$\frac{300\text{mV}}{15\Omega} = 20\text{mA}$$

THEORY OF OPERATION (CONTINUED)**Dimming Modes**

Microsemi's LX1994 provides two dimming options: PWM or DC voltage input.

PWM dimming

A PWM signal applied to S/P pin (see figure 4). This PWM signal is scaled to the reference such that a N% duty cycle PWM signal will produce an LED current of

$$\frac{\{N\% \cdot (10\mu\text{A} + \text{ILS}) \cdot \text{RBRT}\}}{\text{RFB}}$$

If a light sensor (such as Microsemi's LX1970) is used, the light sensor current is applied to the LS pin and adds to the 10 μ A internal current source; in this case the internal current source determines the adjustment range in a pitch black ambient. The PWM signal will scale the light sensor signal allowing the dimming range to increase as the ambient light increases.

DC dimming mode

In "DC dimming mode" (see figure 5) the BRT pin input voltage can be applied directly to BRT pin with the S/P pin pulled high or developed indirectly by applying a PWM signal to the S/P pin and using a scaling resistor and filter capacitor at the BRT pin. The internal current source produces a 10 μ A reference current that is scaled by the resistance applied to the BRT pin.

Protection and IC Shutdown

OVP: The LX1994 provides OVP protections. If the voltage at the OVP pin exceeds the internal reference voltage (1.2V), the converter will suspend switching. The converter will attempt to regulate the OVP pin to its nominal 1.2V.

IC Shutdown: To force the IC into shutdown mode, the S/P pin must pull low for a duration longer 100 μ s. In shutdown mode, the switch is off and the LED string current typically reduces to a few nano amps of leakage current.

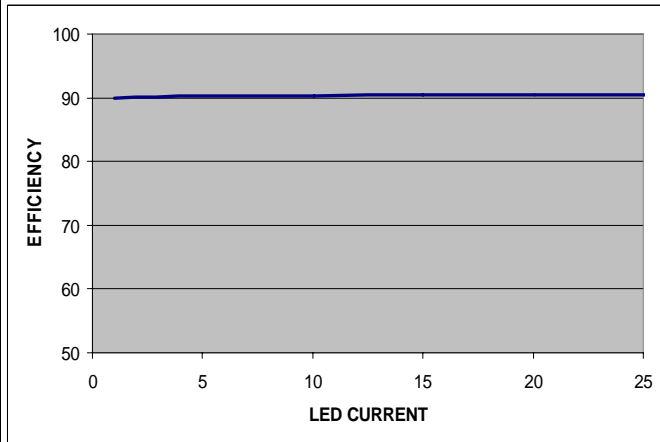
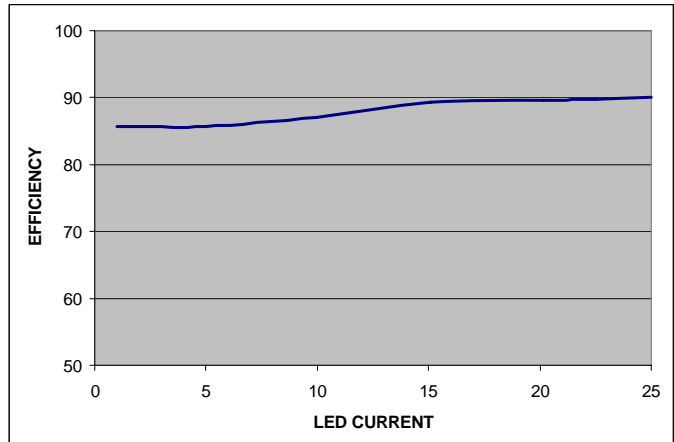
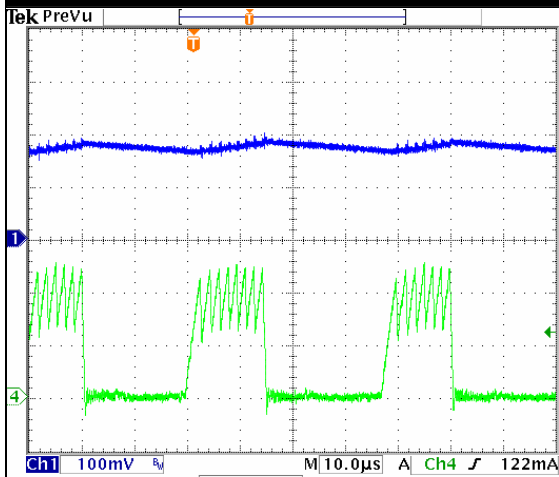
6 LED EFFICIENCY (3.7V INPUT)

14 LED EFFICIENCY (3.7V INPUT)

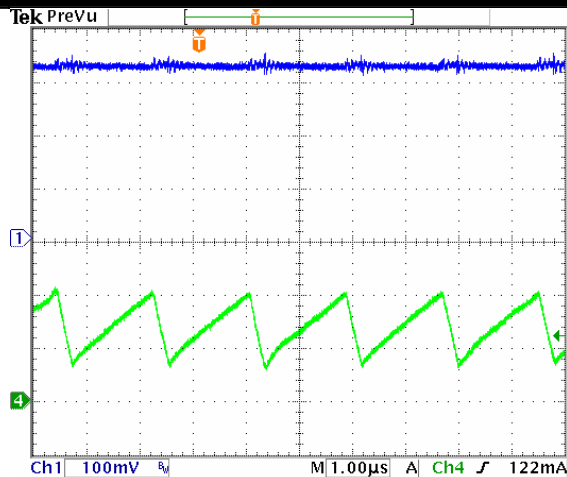
HYSTERETIC MODE WAVEFORMS

blue = sense voltage
Green = inductor current

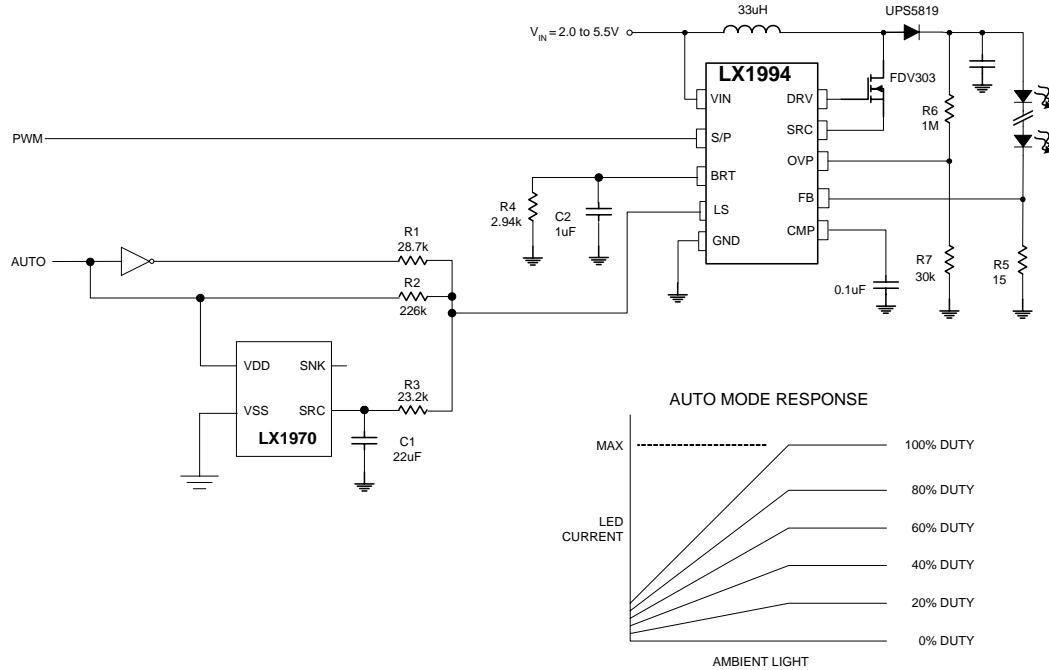
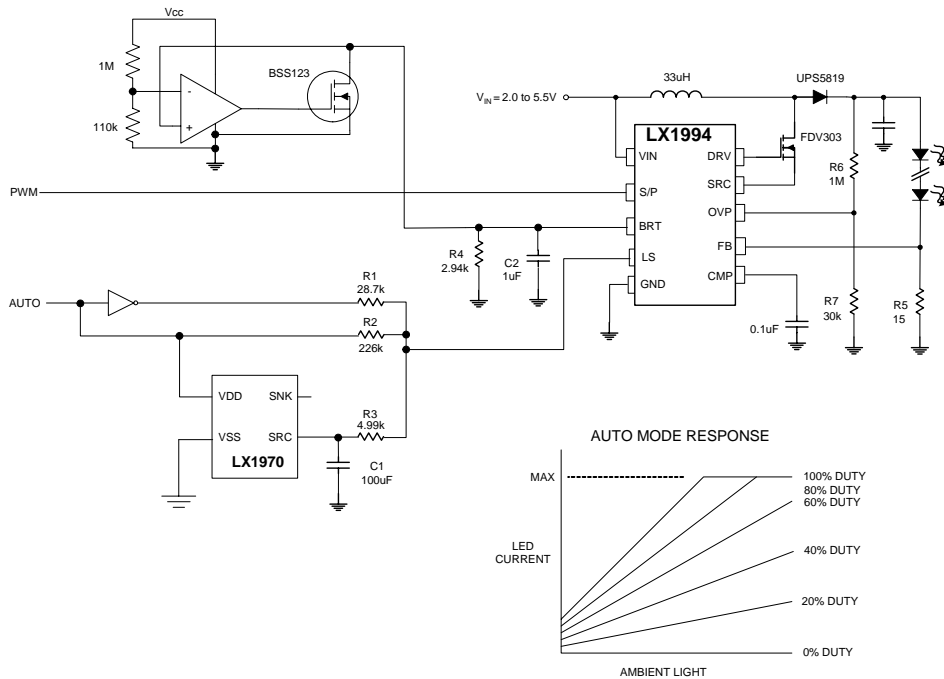
CONTINUOUS MODE WAVEFORMS

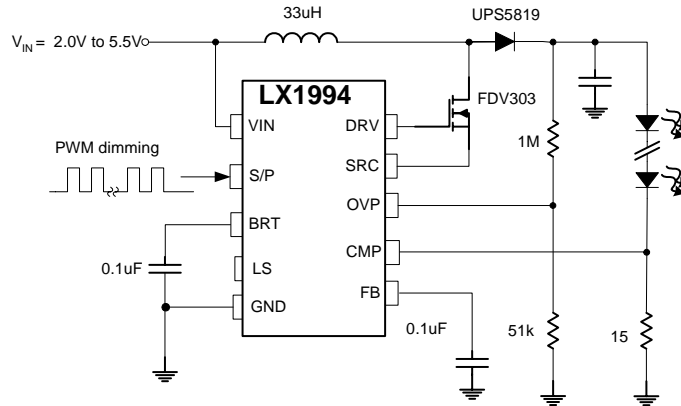
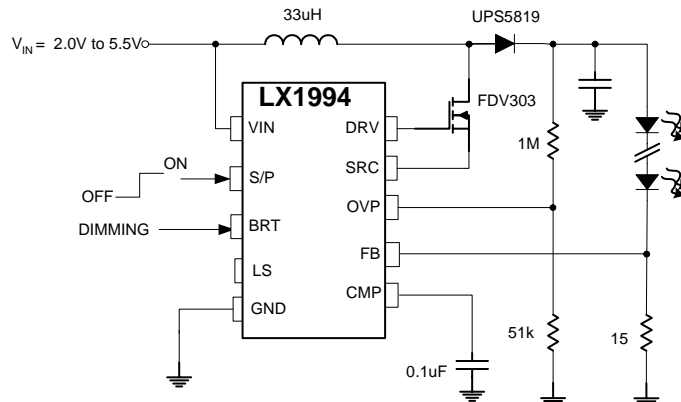
blue = sense voltage
Green = inductor current

APPLICATION CIRCUITS

Figure 2 –PWM Dimming applied to S/P Input and Light Sensor (Dimming option 1)

Figure 3 –PWM Dimming applied to S/P Input and Light Sensor (Dimming option 2)

APPLICATION CIRCUITS

Figure 4 – LED Driver with PWM Dimming applied to S/P Input

Figure 5 – LED Driver with DC Dimming applied to BRT Input

Note: The component values shown are only examples for a working system. Actual values will vary greatly depending on desired parameters, efficiency, and layout constraints.

APPLICATION INFORMATION
OVP PROGRAMMING

Resistors R6 and R7 of Figure 2 program the over voltage clamp level. The value of R6 can be as high (like 1MΩ.) to minimize the quiescent current. The value of R7 can be determined using the following equation where VOVP is found in the ELECTRICAL CHARACTERISTICS TABLE:

$$R7 = R6 \times \left(\frac{V_{OVP}}{V_{OUT} - V_{OVP}} \right)$$

DESIGN EXAMPLE:

Let R6 equal 1M and the required clamp voltage is 25V.

$$R7 = 1M \times R \left(\frac{1.2}{25 - 1.2} \right) = 50.4\Omega$$

INDUCTOR AND CAPACITOR SELECTION

The output filter inductor should be a 1μF capacitor with sufficient voltage rating for the OVP setting. Inductors in the range of 10μH to 47μH work best. For the best efficiency a larger value of inductor such as 47μH is recommended; larger value inductors will reduce ripple current which reduces peak currents and improves efficiency. Smaller value inductors may be use less board space, so a design trade off is in order.

TRANSISTOR AND DIODE SELECTION

A Schottky diode should be used with a 1 Amp current rating and voltage rating equivalent to the OVP setting. The transistor should be a N-channel MOSFET with a logic level gate voltage: good candidates are the FDV303N and the FDN337. For higher voltages, several BSS138 can be wired in parallel.

LAYOUT GUIDELINES

The LX1994 requires a tight layout of the CMP pin capacitance. For best results, the 0.1μF CMP capacitor should be located directly adjacent to the LX1994 package with etch lengths as short as possible.

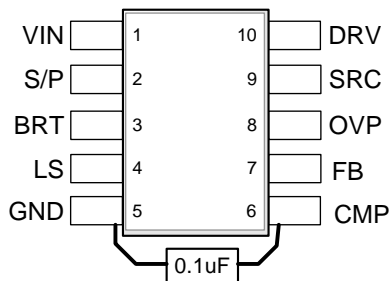
LIGHT SENSOR INTERFACE

The LX1994 has a LS input pin to simplify the interface to an LX1970 light sensor. Two different circuits are described which provide slightly different response curves. The equations for calculating the component values are also given.

For the circuit of Figure 2, the describing equations are:

$$R4 = \frac{R_p \times 30k}{R_p + 30k} \quad \text{or} \quad G4 = G_p - \frac{1}{30k}$$

Auto Mode:

$$I_{LED} = \frac{\text{DutyCycle}}{R5} \times \left[\frac{(I_{SRC} + 10\mu A) \times (R1 \times R2 \times R_p)}{(R1 \times R2) + (R1 \times R_p) + (R2 \times R_p)} + \frac{V_{CC} \times (R1 \times R_p)}{(R1 \times R2) + (R1 \times R_p) + (R2 \times R_p)} \right]$$

$$I_{SRC(MAX)} = \frac{V_{CC} - V_{COMPLIANCE} - V_{BRT(MAX)}}{R3}$$

Manual Mode:

$$I_{LED} = \frac{\text{DutyCycle}}{R5} \times \left[\frac{10\mu A \times (R1 \times R2 \times R_p)}{(R1 \times R2) + (R1 \times R_p) + (R2 \times R_p)} + \frac{V_{CC} \times (R2 \times R_p)}{(R1 \times R2) + (R1 \times R_p) + (R2 \times R_p)} \right]$$

Example:

Select R5 = 15 ohms; ILED = 20mA max; ISRC clamp at 100μA; VCC = 3.3; ILED in full darkness and 100% duty cycle = 4mA.

With R5 = 15 ohms; ILED = 20mA max, VBRT(MAX) = 300mV.

With ISRC clamp at 100μA, Vcompliance (LX1970) = 0.68V, VCC = 3.3V, so

$$R3 = \frac{(3.3 - 0.68 - 0.3)}{100\mu A} = 23.2k$$

APPLICATION INFORMATION
R3 = 23.2k

The level at 100% duty cycle in full darkness is 4mA, which is 20% of the maximum level of 20mA; this implies 80% is attributable to I_{SRC} . Combining this information with the describing equation for AUTO mode gives:

$$80\% \times I_{LED(MAX)} \times R5 = \frac{I_{SRC} \times (R1 \times R2 \times Rp)}{(R1 \times R2) + (R1 \times Rp) + (R2 \times Rp)}$$

This implies:

$$\frac{(R1 \times R2 \times Rp)}{(R1 \times R2) + (R1 \times Rp) + (R2 \times Rp)} = \frac{0.8 \times 0.02 \times 15}{100 \mu A} = 2.4k$$

Since the left side is the three resistors in parallel, this can be restated as:

$$416 \times 10^{-6} = \frac{1}{R1} + \frac{1}{R2} + \frac{1}{Rp} = G1 + G2 + Gp$$

The manual mode equation can be reduced to this assuming 100% duty and 20mA LED current (that is 0.3V sense resistor voltage):

$$\frac{R2 \times Rp}{R2 + Rp} = \frac{0.3 \times R1}{(10 \mu A \times R1) + V_{CC} - 0.3} = \frac{0.3 \times R1}{(10 \mu A \times R1) + 3.0}$$

This can be restated as:

$$\frac{1}{R2} + \frac{1}{Rp} = 33 \times 10^{-6} + \frac{10}{R1} \text{ or } G2 + Gp = 33 \times 10^{-6} + (10 \times G1)$$

The auto mode equation can be reduced to this assuming 100% duty, 100 μ A I_{SRC} current and 20mA LED current (that is 0.3V sense resistor voltage):

$$\frac{R1 \times Rp}{R1 + Rp} = \frac{0.3 \times R2}{(I_{SRC} + 10 \mu A) \times R2 + V_{CC} - 0.3}$$

$$= \frac{0.3 \times R2}{(100 \mu + 10 \mu A) \times R2 + V_{CC} - 0.3} = \frac{0.3 \times R2}{(110 \mu A \times R2) + 3.0}$$

This can be restated as:

$$\frac{1}{R1} + \frac{1}{Rp} = 367 \times 10^{-6} + \frac{10}{R2} \text{ or } G1 + Gp = 367 \times 10^{-6} + (10 \times G2)$$

The equations above can be solved for G1, G2 and Gp:

$$G1 = 34.8 \times 10^{-6}$$

$$G2 = 4.45 \times 10^{-6}$$

$$Gp = 376 \times 10^{-6}$$

Knowing Gp we can find

$$G4 = Gp - \frac{1}{30k} = 343 \times 10^{-6}$$

The resistance values are the reciprocal of the conductance's so:

$$R1 = 28.7k$$

$$R2 = 225k$$

$$R4 = 2.91k$$

The value of C1 is selected to give a time constant of 1/2 second and works into R3 (which is 23.2k).

$$C1 = \frac{0.5}{23.2k} \quad C1 = 21.5 \mu F$$

The value of C2 works into Rp and the pole should be set at 1/100 of the PWM frequency.

$$C2 = \frac{1}{6.28 \times \frac{10kHz}{100} \times 2.66k}$$

For a 10KHz PWM, C2 = 599nF, and a value of 1 μ F works well.

Circuit of Figure 3:

The second light sensor interface is very similar to the first; the choice is a matter of user preference. In the second circuit, an active 325mV clamp is used to clamp the maximum LED current in auto mode.

In this circuit, resistor R3 is reduced to extend the operating ambient light range of the light sensor and filter capacitor C1 must therefore be increased.

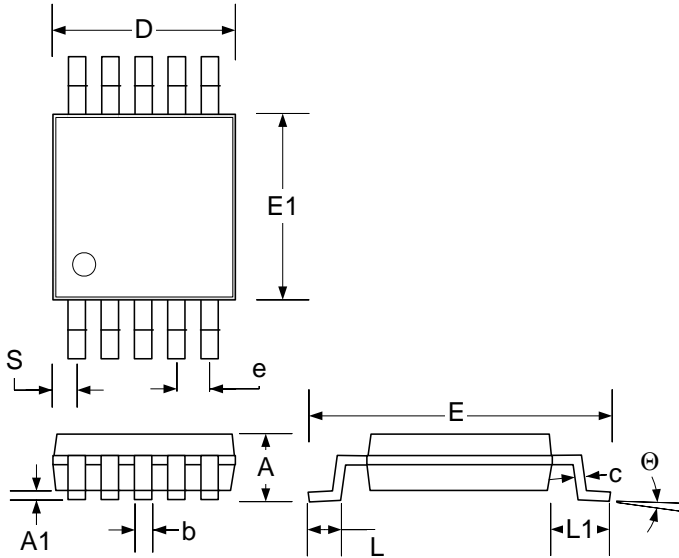
PACKAGE DIMENSIONS
DU 10-Pin Miniature Shrink Outline Package (MSOP)

Dim	MILLIMETERS		INCHES	
	MIN	MAX	MIN	MAX
A	—	1.10	—	0.043
A1	0.05	0.15	0.002	0.006
b	0.15	0.30	0.006	0.012
c	0.13	0.23	0.005	0.009
D	2.90	3.10	0.114	0.122
e	0.50 BSC		0.020 BSC	
E	4.75	5.05	0.187	0.198
E1	2.90	3.10	0.114	0.122
L	0.41	0.70	0.016	0.028
L1	0.95 BSC		0.037 BSC	
S	0.50 BSC		0.020	
Θ	0°	6°	0°	6°

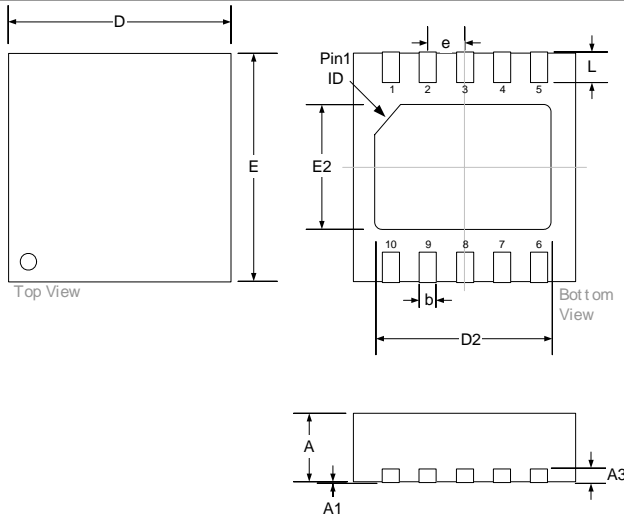
LD 10-Pin Plastic Micro Lead frame Package (MLP)

Dim	MILLIMETERS		INCHES	
	MIN	MAX	MIN	MAX
A	0.80	1.00	0.0315	0.0394
A1	0	0.05	0	0.0019
A3	0.20 REF		0.0079 REF	
b	0.18	0.30	0.0071	0.0118
D	3.00 BSC		0.1181 BSC	
D2	2.23	2.48	0.0878	0.0976
e	0.50 BSC		0.0197 BSC	
E	3.00 BSC		0.1181 BSC	
E2	1.49	1.74	0.0587	0.0685
L	0.30	0.50	0.0071	0.0197

Note: Dimensions do not include mold flash or protrusions; these shall not exceed 0.155mm(.006") on any side.



Microsemi[®]

LX1994

High Efficiency LED Driver

PRODUCTION DATA SHEET

NOTES

PRODUCTION DATA – Information contained in this document is proprietary to Microsemi and is current as of publication date. This document may not be modified in any way without the express written consent of Microsemi. Product processing does not necessarily include testing of all parameters. Microsemi reserves the right to change the configuration and performance of the product and to discontinue product at any time.