

DESCRIPTION

The LX1993 is a high efficiency step-up boost converter that features a pseudo-hysteretic pulse frequency modulation topology for driving white or color LEDs in backlight or frontlight systems. Designed for maximum efficiency, reduced board size, and minimal cost, the LX1993 is ideal for PDA and digital camera applications. The LX1993 features an internal N-Channel MOSFET and control circuitry that is optimized for portable system design applications. The LX1993 promotes improved performance in battery-operated systems by operating with a quiescent supply current 70 μ A (typical) and a shutdown current of less than 1 μ A. The input voltage range is from 1.6V to 6.0V thus allowing for a broad selection of battery voltage applications and start-up is

guaranteed at 1.6V input.

The LX1993 is capable of switching currents in excess of 300mA and the output current is readily programmed using one external current sense resistor in series with the LEDs. This configuration provides a feedback signal to the FB pin thus maintaining constant output current regardless of varying LED forward voltage (V_F). The LX1993 provides an additional feature for simple dynamic adjustment of the output current (i.e., up to 100% of the maximum programmed current). Designers can make this adjustment by generating an analog reference signal or a PWM signal applied directly to the ADJ pin and any PWM amplitude is readily accommodated via a single external resistor. The LX1993 is available in the 8-Pin MSOP and thus requires a very small PCB area.

KEY FEATURES

- > 80% Maximum Efficiency
- 70 μ A Typical Quiescent Supply Current
- Externally Programmable Peak Inductor Current Limit For Maximum Efficiency
- Logic Controlled Shutdown
- < 1 μ A Shutdown Current
- Dynamic Output Current Adjustment Via Analog Reference Or Direct PWM Input
- 8-Pin MSOP Package

APPLICATIONS

- Pagers
- Wireless Phones
- PDAs
- Handheld Computers
- LED Driver
- Digital Camera Displays

IMPORTANT: For the most current data, consult MICROSEMI's website: <http://www.microsemi.com>

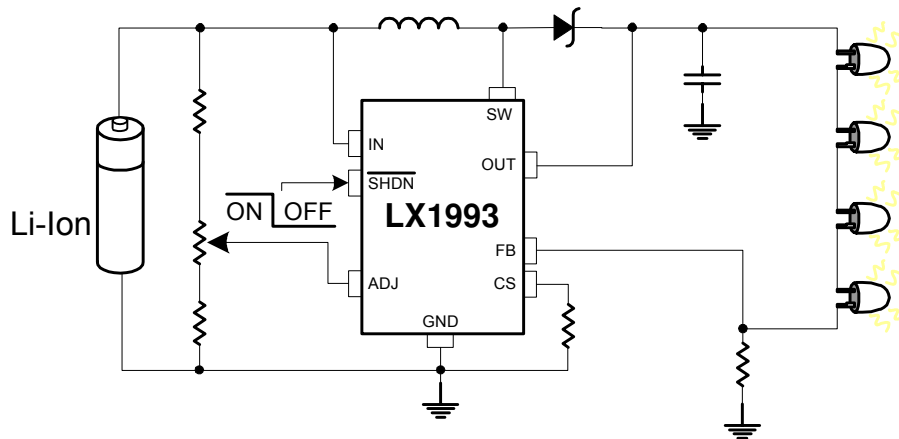
PRODUCT HIGHLIGHT

PACKAGE ORDER INFO

| | |
|------------|---|
| T_A (°C) | DU Plastic MSOP 8-Pin |
| | RoHS Compliant / Pb-free Transition DC: 0432 |
| 0 to 70 | LX1993CDU |

Note: Available in Tape & Reel. Append the letters "TR" to the part number. (i.e. LX1993CDU-TR)

ABSOLUTE MAXIMUM RATINGS

| | |
|--|-------------------------------|
| Supply Voltage (V_{IN}) | -0.3V to 7.0V |
| Feedback Input Voltage (V_{FB}) | -0.3V to $V_{IN} + 0.3V$ |
| Shutdown Input Voltage (V_{SHDN}) | -0.3V to $V_{IN} + 0.3V$ |
| Adjust Input Voltage (V_{ADJ}) | -0.3V to $V_{IN} + 0.3V$ |
| Output Voltage (V_{OUT}) | -0.3V to 25V |
| Switch Voltage (V_{SW}) | -0.3V to ($V_{OUT} + 1.0V$) |
| Switch Current (I_{SW}) | 500mA rms |
| Operating Junction Temperature | 150°C |
| Storage Temperature Range | -65°C to 150°C |
| Peak Package Solder Reflow Temp. (40 second max. exposure) | 260°C (+0, -5) |

Note: Exceeding these ratings could cause damage to the device. All voltages are with respect to Ground. Currents are positive into, negative out of specified terminal.

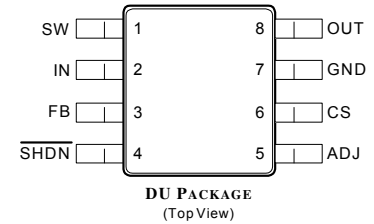
PACKAGE PIN OUT

RoHS / Pb-free 100% Matte Tin Lead Finish

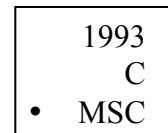
FRONT MARKING

- pin 1 indicator

THERMAL DATA
DU Plastic MSOP 8-Pin

| | |
|---|---------|
| THERMAL RESISTANCE-JUNCTION TO AMBIENT, θ_{JA} | 206°C/W |
| THERMAL RESISTANCE-JUNCTION TO CASE, θ_{JC} | 39°C/W |

Junction Temperature Calculation: $T_J = T_A + (P_D \times \theta_{JC})$.

The θ_{JA} numbers are guidelines for the thermal performance of the device/pc-board system. All of the above assume no ambient airflow.

FUNCTIONAL PIN DESCRIPTION

| NAME | DESCRIPTION |
|-------------------|--|
| IN | Unregulated IC Supply Voltage Input – Input range from +1.6V to +6.0V. Bypass with a 1 μ F or greater capacitor for low voltage operation. |
| FB | Feedback Input – Connect to a current sense resistor between the load and GND to set the maximum output current. |
| \overline{SHDN} | Active-Low Shutdown Input – A logic low shuts down the device and reduces the supply current to <1 μ A. Connect \overline{SHDN} to V_{CC} for normal operation. |
| SW | Inductor Switching Connection – Internally connected to the drain of a 28V N-channel MOSFET. SW is high impedance in shutdown. |
| CS | Current-Sense Amplifier Input – Connecting a resistor between CS and GND sets the peak inductor current limit. |
| GND | Common terminal for ground reference. |
| ADJ | Output Current Adjustment Input – Provides the internal reference for the output current feedback. The signal input can be either a PWM signal or analog voltage allowing a dynamic output current adjustment. The signal should typically range from 500mV to GND, but is capable of an input up to V_{IN} . Caution should be used not to exceed the device output current rating. |
| OUT | Output Current - Adjustable up to 25mA. Load voltage should not exceed 25V. |

ELECTRICAL CHARACTERISTICS

Unless otherwise specified, the following specifications apply over the operating ambient temperature $0^{\circ}\text{C} \leq T_A \leq 70^{\circ}\text{C}$ except where otherwise noted and the following test conditions: $V_{\text{IN}} = 3\text{V}$, $V_{\text{FB}} = 0.3\text{V}$, $V_{\text{ADJ}} = 0.2\text{V}$ and SW pin has $+5\text{V}$ through 39.2Ω , $\text{SHDN} = V_{\text{IN}}$ and $\text{CS} = \text{GND}$.

| Parameter | Symbol | Test Conditions | LX1993 | | | Units |
|--|---------------------|---|--------|------|-----------------|------------------------|
| | | | Min | Typ | Max | |
| Operating Voltage | V_{IN} | | 1.6 | | 6.0 | V |
| Minimum Start-up Voltage | V_{SU} | $T_A = +25^{\circ}\text{C}$ | | | 1.6 | V |
| Start-up Voltage Temperature Coefficient | k_{VST} | Guaranteed; not tested | | -2 | | mV/ $^{\circ}\text{C}$ |
| Quiescent Current | I_{Q} | Not switching | | 70 | 100 | μA |
| | | $V_{\text{SHDN}} < 0.4\text{V}$ | | 0.2 | 0.5 | μA |
| FB Threshold Voltage | V_{FB} | | 275 | 300 | 325 | mV |
| FB Input Bias Current | I_{FB} | Switching $V_{\text{ADJ}} = 0.4\text{V}$ | -100 | | 100 | nA |
| ADJ Input Voltage Range | V_{ADJ} | | 0.0 | | V_{IN} | V |
| ADJ Input Bias Current | I_{ADJ} | $V_{\text{ADJ}} < 0.3\text{V}$ | -150 | | 50 | nA |
| Shutdown Input Bias Current | I_{SHDN} | $V_{\text{SHDN}} = 0\text{V}$ | -100 | | 100 | nA |
| Shutdown High Input Voltage | V_{SHDN} | | 1.6 | | | V |
| Shutdown Low Input Voltage | V_{SHDN} | | | | 0.4 | V |
| Current Sense Bias Current | I_{CS} | | 2 | | 6 | μA |
| Minimum Peak Current | I_{MIN} | $R_{\text{CS}} = 0\Omega$ | 85 | | 155 | mA |
| Internal NFET On-resistance | $R_{\text{DS(ON)}}$ | $T_A = +25^{\circ}\text{C}$; $I_{\text{SW}} = 10\text{mA}$; $V_{\text{FB}} = 1\text{V}$ | | 1.1 | | Ω |
| Switch Pin Leakage Current | I_{LEAK} | $V_{\text{SW}} = 25\text{V}$ | | 0.23 | | μA |
| Maximum Switch Off-Time | t_{OFF} | $V_{\text{FB}} = 1\text{V}$ | 100 | 300 | 500 | ns |
| Diode Forward Voltage | V_{F} | $T_A = +25^{\circ}\text{C}$; $I_{\text{F}} = 150\text{mA}$ | | 1.0 | | V |
| Diode Reverse Current | I_{R} | $T_A = +25^{\circ}\text{C}$; $V_{\text{R}} = 25\text{V}$ | | 1.5 | | μA |

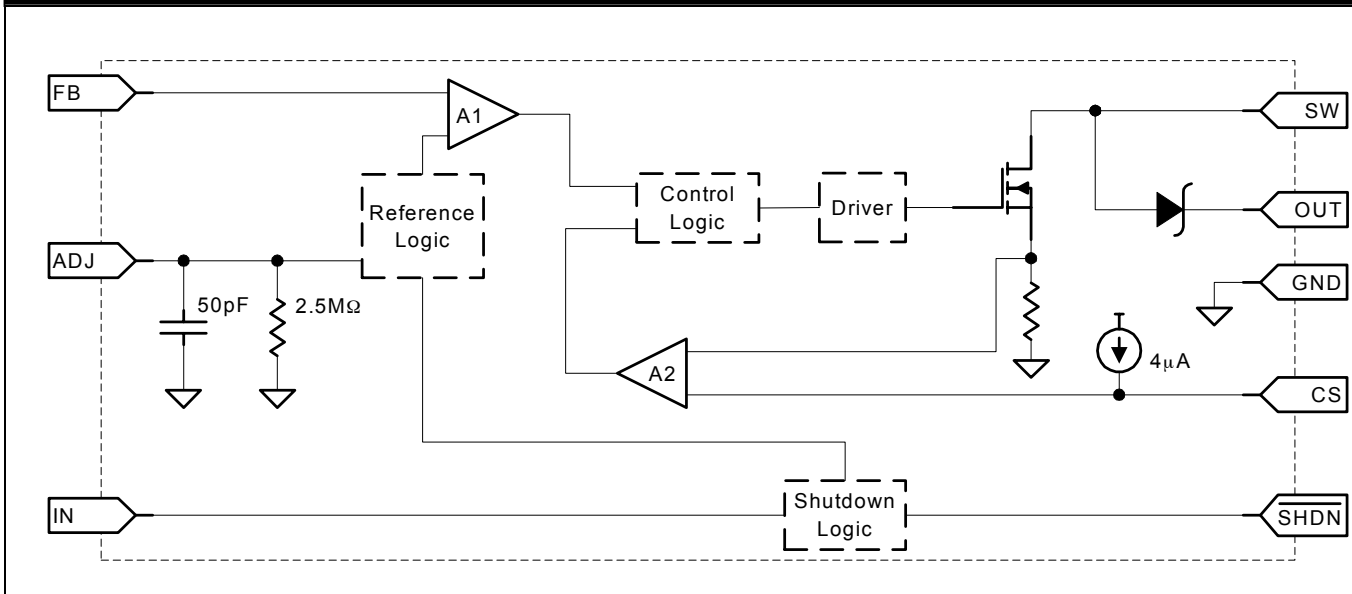
SIMPLIFIED BLOCK DIAGRAM

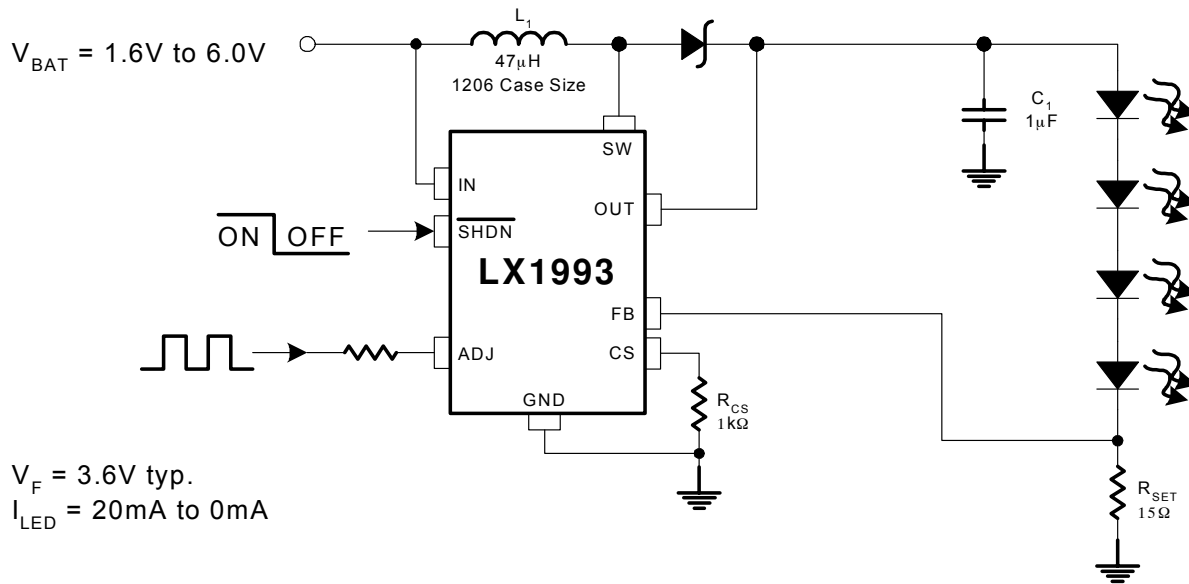
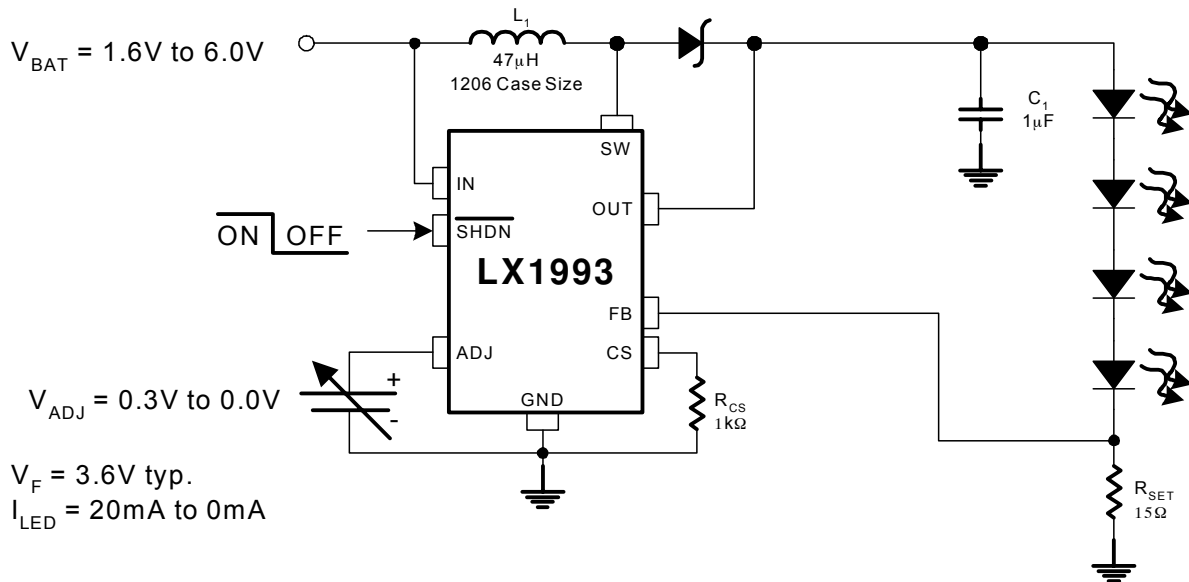
APPLICATION CIRCUITS
Typical LED Driver Applications

Figure 1 – LED Driver with Full-Range Dimming Via PWM Input

Figure 2 – LED Driver with Full-Range Dimming Via Analog Voltage Input

Note: The component values shown are only examples for a working system. Actual values will vary greatly depending on desired parameters, efficiency, and layout constraints.

APPLICATION INFORMATION
OPERATING THEORY

The LX1993 is a PFM boost converter that is optimized for driving a string of series connected LEDs. It operates in a pseudo-hysteretic mode with a fixed switch "off time" of 300ns. Converter switching is enabled as LED current decreases causing the voltage across R_{SET} to decrease to a value less than the voltage at the VADJ pin. When the voltage across R_{SET} (i.e., V_{FB}) is less than VADJ, comparator A1 activates the control logic. The control logic activates the DRV output circuit that connects to the gate of the internal FET. The output (i.e., SW) is switched "on" (and remains "on") until the inductor current ramps up to the peak current level. This current level is set via the external R_{CS} resistor and monitored through the CS input by comparator A2.

The LED load is powered from energy stored in the output capacitor during the inductor charging cycle. Once the peak inductor current value is achieved, the output is turned off (off-time is typically 300ns) allowing a portion of the energy stored in the inductor to be delivered to the load (e.g., see Figure 6, channel 2). This causes the output voltage to continue to rise across R_{SET} at the input to the feedback circuit. The LX1993 continues to switch until the voltage at the FB pin exceeds the control voltage at the ADJ pin. The value of R_{SET} is established by dividing the maximum adjust voltage by the maximum series LED current. A minimum value of 15Ω is recommended for R_{SET} . The voltage at the FB pin is the product of I_{OUT} (i.e., the current through the LED chain) and R_{SET} .

$$R_{SET} = \left[\frac{V_{ADJmax}}{I_{LEDmax}} \right]$$

The application of an external voltage source at the ADJ pin provides for output current adjustment over the entire dimming range and the designer can select one of two possible methods. The first option is to connect a PWM logic signal to the ADJ pin (e.g., see Figure 1). The LX1993 includes an internal 50pF capacitor to ground that works with an external resistor to create a low-pass filter (i.e., filter out the AC component of a pulse width modulated input of $f_{PWM} \geq 100\text{KHz}$). The second option is to adjust the reference voltage directly at the ADJ pin by applying a DC voltage from 0.0 to 0.3V (e.g., see Figure 2). The adjustment voltage level is selectable (with limited accuracy) by implementing the voltage divider created between the external series resistor and the internal 2.5M Ω resistor. Disabling the LX1993 is achieved by driving the SHDN pin with a low-level logic signal thus reducing the device power consumption to approximately 0.5 μA (typ).

INDUCTOR SELECTION AND OUTPUT CURRENT LIMIT PROGRAMMING

Setting the level of peak inductor current to approximately **2X** the expected maximum DC input current will minimize the inductor size, the input ripple current, and the output ripple voltage. The designer is encouraged to use inductors that will not saturate at the peak inductor current level. An inductor value of 47 μH is recommended. Choosing a lower value emphasizes peak current overshoot while choosing a higher value emphasizes output ripple voltage. The peak switch current is defined using a resistor placed between the CS terminal and ground and the I_{PEAK} equation is:

$$I_{PEAK} = I_{MIN} + \left(\frac{V_{IN}}{L} \right) t_D + (I_{SCALE}) R_{CS}$$

The maximum I_{PEAK} value is limited by the I_{SW} value (max. = 500mA rms). The minimum I_{PEAK} value is defined when R_{CS} is zero. The minimum I_{PEAK} value is defined when R_{CS} is zero. A typical value for the minimum peak current (I_{MIN}) at 25°C is 197mA. The parameter t_D is related to internal operation of comparator A. A typical value at 25°C is 850ns. A typical value of I_{SCALE} at 25°C is 44mA per K Ω . All of these parameters have an effect on the final I_{PEAK} value.

DESIGN EXAMPLE:

Determine I_{PEAK} where V_{IN} equals 3.0V and R_{CS} equals 4.02K Ω using nominal values for all other parameters.

$$I_{PEAK} = 197\text{mA} + \left(\frac{3.0\text{V}}{47\mu\text{H}} \right) \times 850\text{ns} + \left(\frac{44\text{mA}}{\text{K}\Omega} \right) \times 4.02\text{K}\Omega$$

The result of this example yields a nominal I_{PEAK} of approximately 428mA.

OUTPUT RIPPLE AND CAPACITOR SELECTION

Output voltage ripple is a function of the inductor value (L), the output capacitor value (C_{OUT}), the peak switch current setting (I_{PEAK}), the load current (I_{OUT}), the input voltage (V_{IN}) and the output voltage (V_{OUT}) for a this boost converter regulation scheme. When the switch is first turned on, the peak-to-peak voltage ripple is a function of the output droop (as the inductor current charges to I_{PEAK}), the feedback transition error (i.e., typically 10mV), and the output overshoot (when the stored energy in the inductor is delivered to the load at the end of the charging cycle). Therefore the total ripple voltage is

$$V_{RIPPLE} = \Delta V_{DROOP} + \Delta V_{OVERSHOOT} + 10\text{mV}$$

The initial droop can be estimated as follows where the 0.5V value in the denominator is an estimate of the voltage drop across the inductor and the FET R_{DS_ON} :

APPLICATION INFORMATION

$$\Delta V_{\text{DROOP}} = \frac{\left(\frac{L}{C_{\text{OUT}}}\right) \times (I_{\text{PK}} \times I_{\text{OUT}})}{(V_{\text{IN}} - 0.5)}$$

The output overshoot can be estimated as follows where the 0.5 value in the denominator is an estimate of the voltage drop across the diode:

$$\Delta V_{\text{OVERSHOOT}} = \frac{\frac{1}{2} \times \left(\frac{L}{C_{\text{OUT}}}\right) \times (I_{\text{PK}} - I_{\text{OUT}})^2}{(V_{\text{OUT}} + 0.5 - V_{\text{IN}})}$$

DESIGN EXAMPLE:

Determine the V_{RIPPLE} where I_{PK} equals 200mA, I_{OUT} equals 13.0mA, L equals 47 μ H, C_{OUT} equals 4.7 μ F, V_{IN} equals 3.0V, and V_{OUT} equals 13.0V:

$$\Delta V_{\text{DROOP}} = \frac{\left(\frac{47\mu\text{H}}{4.7\mu\text{F}}\right) \times (200\text{mA} \times 12.8\text{mA})}{(13.0 - 0.5)} \approx 2.0\text{mV}$$

$$\Delta V_{\text{OVERSHOOT}} = \frac{\frac{1}{2} \times \left(\frac{47\mu\text{H}}{4.7\mu\text{F}}\right) \times (200\text{mA} - 12.8\text{mA})^2}{(13.0 + 0.5 - 3.0)} \approx 18.4\text{mV}$$

Therefore, $V_{\text{RIPPLE}} = 2.0\text{mV} + 18.4\text{mV} + 10\text{mV} = 30.4\text{mV}$

DIODE SELECTION

A Schottky diode is recommended for most applications (e.g., Microsemi UPS5817). The low forward voltage drop and fast recovery time associated with this device supports the switching demands associated with this circuit topology. The designer is encouraged to consider the diode's average and peak current ratings with respect to the application's output and peak inductor current requirements. Further, the diode's reverse breakdown voltage characteristic must be capable of withstanding a negative voltage transition that is greater than V_{OUT} .

PCB LAYOUT

The LX1993 produces high slew-rate voltage and current waveforms hence; the designer should take this into consideration when laying out the circuit. Minimizing trace lengths from the IC to the inductor, diode, input and output capacitors, and feedback connection (i.e., pin 3) are typical considerations. Moreover, the designer should maximize the DC input and output trace widths to accommodate peak current levels associated with this topology.

EVALUATION BOARD

The LXE1993 evaluation board is available from Microsemi for assessing overall circuit performance. The evaluation board, shown in Figure 3, is 3 by 3 inches (i.e., 7.6 by 7.6cm) square and programmed to drive 2 to 4 LEDs (provided). Designers can easily modify circuit parameters to suit their particular application by replacing R_{CS} (as described in this section) R_{SET} (i.e., R4) and LED load. Moreover, the inductor, FET, and switching diode are easily swapped out to promote design verification of a circuit that maximizes efficiency and minimizes cost for a specific application. The evaluation board input and output connections are described in Table 1.

The DC input voltage is applied to VBAT (not VCC) however the LX1993 IC may be driven from a separate DC source via the VCC input. The output current (i.e., LED brightness) is controlled by adjusting the on-board potentiometer. The designer may elect to drive the brightness adjustment circuit from VBAT or via a separate voltage source by selecting the appropriate jumper position (see Table 2). Optional external adjustment of the output LED current is achieved by disengaging the potentiometer and applying either a DC voltage or a PWM-type signal to the VADJ input. The PWM signal frequency should be higher than 150KHz and contain a DC component less than 350mV.

The LX1993 exhibits a low quiescent current ($I_{\text{Q}} < 0.5\mu\text{A}$: typ) during shutdown mode. The SHDN pin is used to exercise the shutdown function on the evaluation board. This pin is pulled-up to VCC via a 10K Ω resistor. Grounding the SHDN pin shuts down the IC (not the circuit output). The output voltage (i.e., voltage across the LED string) is readily measured at the VOUT terminal and LED current is derived from measuring the voltage at the VFDBK pin and dividing this value by 15 Ω (i.e., R4). The factory installed component list for this must-have design tool is provided in Table 3 and the schematic is shown in Figure 4.

Efficiency Measurement Hint: When doing an efficiency evaluation using the LX1993 Evaluation Board, VPOT should be driven by a separate voltage supply to account for losses associated with the onboard reference (i.e., the 1.25V shunt regulator and 1K Ω resistor). This circuit will have VBAT - 1.25V across it and at the higher input voltages the 1K Ω resistor could have as much as 4mA through it. This shunt regulator circuitry will adversely effect the overall efficiency measurement. It is not normally used in an application; hence, it should not be considered when measuring efficiency.

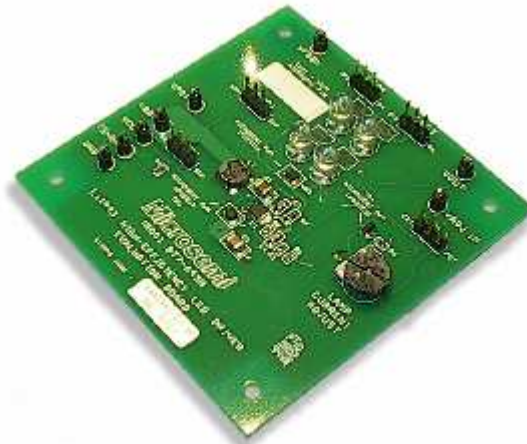
APPLICATION INFORMATION (CONTINUED)

Figure 3: LX1993 Engineering Evaluation Board
Table 1: Input and Output Pin Assignments

| Pin Name | Allowable Range | Description |
|----------|-----------------|--|
| VBAT | 0 to 6V | Main power supply for output. (Set external current limit to 0.5A) |
| VCC | 1.6V to 6V | LX1993 power. May be strapped to VBAT or use a separate supply if VCC jumper is in the SEP position. Do not power output from VCC pin on board.. |
| VPOT | 1.6V to 6V | Potentiometer power. May be strapped to VBAT or use a separate supply if VPOT jumper is in the SEP position. Do not power output from VPOT pin on board. |
| VADJ IN | 0 to 350mV | Apply a DC voltage or a PWM voltage to this pin to adjust the LED current. PWM inputs should be greater than 120Hz and DC portion less than 350mV. |
| /SHDN | 0 to VCC | Pulled up to VCC on board (10K Ω), Ground to inhibit the LX1992. |
| VOUT | 0 to 18V | Power supply output voltage that is applied to LED string. |
| VFDBK | 0 to 400mV | Sense resistor voltage. Divide this voltage by 15 to determine LED current. |

Table 2: Jumper Pin Position Assignments

| Jumper Position | Functional Description |
|-----------------|--|
| VCC/ BAT | Use this position when powering VBAT and VCC from the same supply. Do not connect power to the VCC input when using this jumper position. |
| VCC/ SEP | Use this position when using a separate VCC supply (different from VBAT). |
| VPOT/ VBAT | Use this position when powering the potentiometer reference circuit from the VBAT supply. Do not connect power to the VCC input when using this jumper position. |
| VPOT/ SEP | Use this position when using a separate power supply (different from VBAT) to power the potentiometer reference circuit. This will lower the VBAT current and provide a more accurate efficiency reading for the LX1993 circuit. |
| ADJ/ POT | Use this position when using the potentiometer to adjust LED current. |
| ADJ/ EXT | Use this position when adjusting the LED current with an external PWM that has a repetition rate >120Hz. Or when using a DC adjustment voltage. |
| LED# OFF | Use this position to short out LED # 3 and / or LED # 4. |

Note: Always put jumpers in one of the two possible positions

APPLICATION INFORMATION (CONTINUED)

Table 3: Factory Installed Component List for the LX1993 Evaluation Board

| Quantity | Part Reference | Description | Manufacturer | Part Number |
|----------|----------------|---|-------------------|-----------------|
| 1 | CR1 | Rectifier, Schottky, 1A, 20V, Powermite Type SMT | Microsemi | UPS5817 |
| 1 | L1 | Inductor, 47uH, 540mA, SMT | Toko | A920CY-470 |
| 2 | C1, C2 | Capacitor, Ceramic X5R, 4.7uF, 25V, 1210 Type SMT | Taiyo Yuden | CETMK325BJ475MN |
| 2 | C3, C4 | Capacitor, Ceramic X7R, 0.1uF, 50V, 0805 Type SMT | Murata | GRM40X7R104M050 |
| 1 | R4 | Resistor, 15 Ohm, 1/10W, 0805 Type SMT | Panasonic | ERJ6ENF15R0 |
| 1 | R3 | Resistor, 590K, 1/16W, 0603 Type SMT | Panasonic | ERJ3EKF5903 |
| 1 | R2 | Resistor, 100, 1/16W, 0603 Type SMT | Panasonic | ERJ3EKF1000 |
| 2 | R6, R8 | Resistor, 100K, 1/16W, 0603 Type SMT | Panasonic | ERJ3EKF1003 |
| 1 | R1, R5 | Resistor, 10K, 1/16W, 0603 Type SMT | Panasonic | ERJ3EKF1002 |
| 1 | R7 | Trimpot, 50K, 1/2W, Through Hole Type | Bourns | 3352E-1-503 |
| 1 | VR1 | IC, Voltage Reference, 1.25 Volts, SOT23 Type SMT | Microsemi | LX432CSC |
| 1 | VR2 | Diode, Zener, 20V, 1W Powermite Type SMT | Microsemi | 1PMT4114 |
| 4 | LED1 - 4 | White LED | Chicago Miniature | CMD333UWC |
| 5 | JB1 - JB3 | Header, 3 Pos Vertical Type | 3M | 929647-09-36 |
| 5 | | Jumper | 3M | 929955-06 |

Note: The minimum set of parts needed to build a working power supply are: CR1, L1, C1, C2, R2, R4, U1. Evaluation board P/L subject to change without notice.

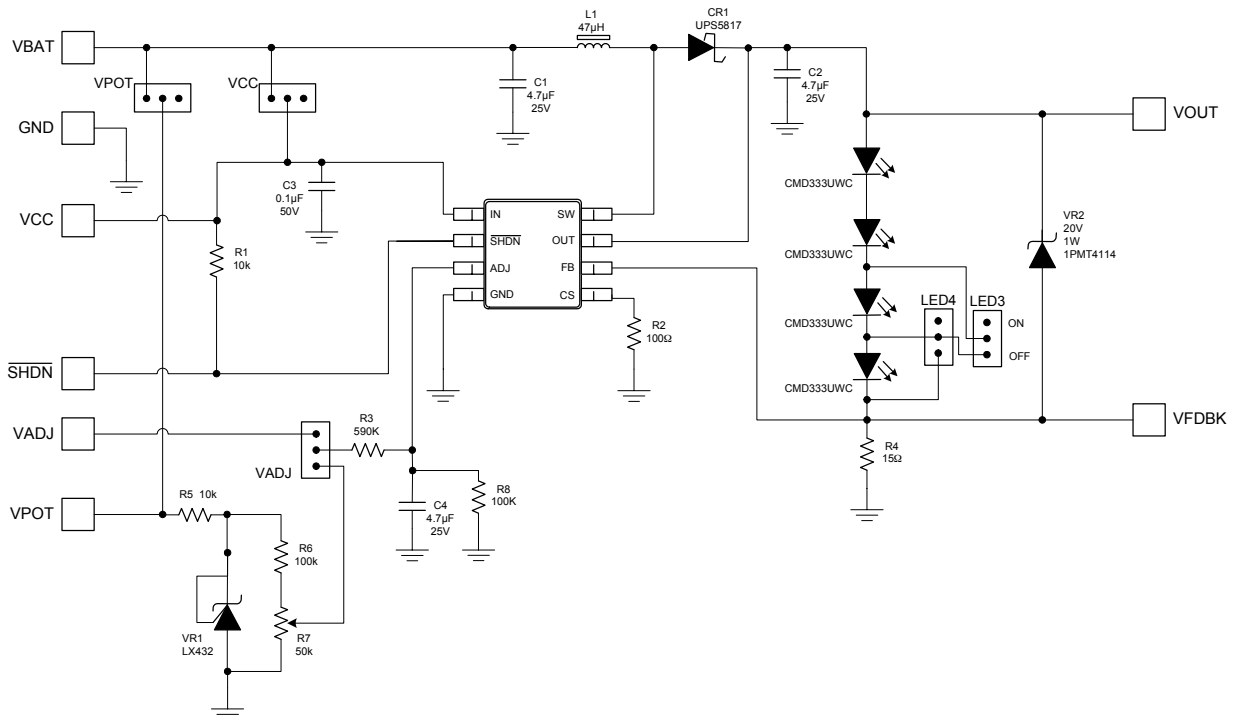

Figure 4 – LX1993 Boost Evaluation Board Schematic

CHARACTERISTIC CURVES

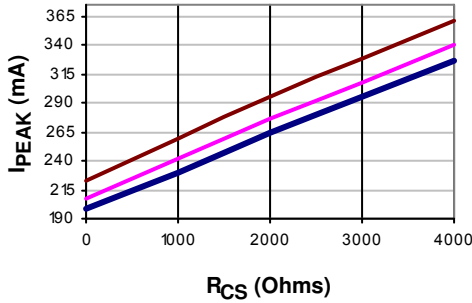

Figure 5: Example of Peak Current versus R_{CS} value

Conditions:

$V_{IN} = 2.5V$ (bottom), $3.3V$ (middle) & $4.5V$ (top)
@ $T_A = 25^\circ C$

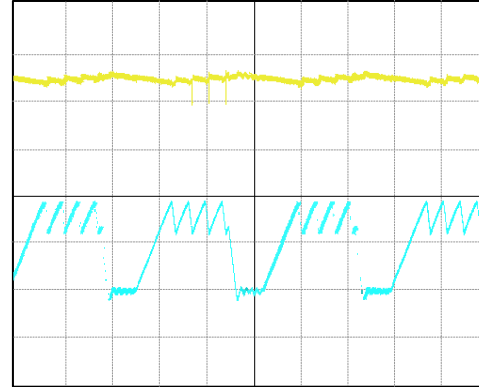

Figure 6: V_{OUT} and Inductor Current Waveforms.

Channel 1: V_{OUT} (AC coupled; 100mV/div)

Channel 2: Inductor Current (100mA/div.)

4 LED Configuration: $V_{IN} = 3.0V$

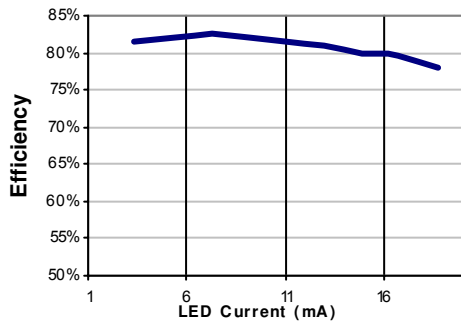

Figure 7: Efficiency vs. LED Output Current.

2 LED Configuration: $V_{IN} = 3.5V$, $L = 47\mu H$, $R_{CS} = 100\Omega$

Note: Data taken from LXE1993 Evaluation Board

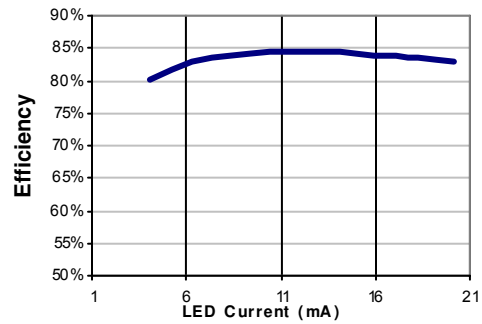

Figure 8: Efficiency vs. LED Output Current.

2 LED Configuration: $V_{IN} = 5.0V$, $L = 47\mu H$, $R_{CS} = 100\Omega$

Note: Data taken from LXE1993 Evaluation Board

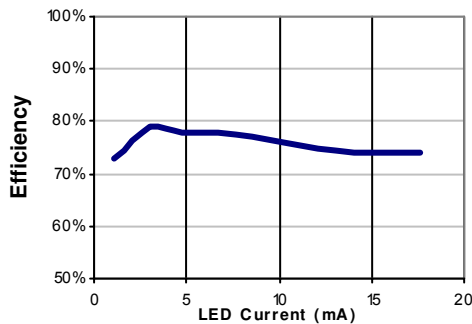

Figure 9: Efficiency vs. LED Output Current.

4 LED Configuration: $V_{IN} = 3.5V$, $L = 47\mu H$, $R_{CS} = 100\Omega$

Note: Data taken from LXE1993 Evaluation Board

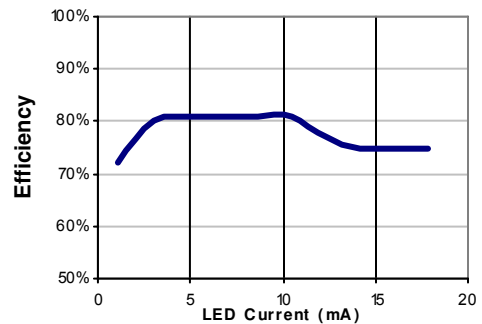

Figure 10: Efficiency vs. LED Output Current.

4 LED Configuration: $V_{IN} = 5.0V$, $L = 47\mu H$, $R_{CS} = 100\Omega$

Note: Data taken from LXE1993 Evaluation Board

CHARACTERISTIC CURVES

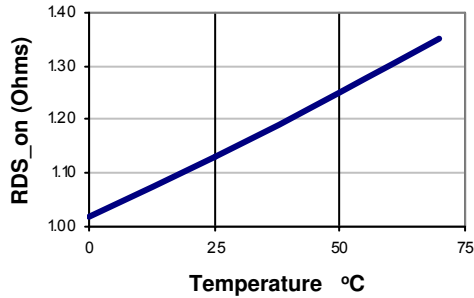

Figure 11: $R_{DS(on)}$ vs. Temperature
Condition: $V_{IN} = 3.0V$; $I_{SW} = 10mA$

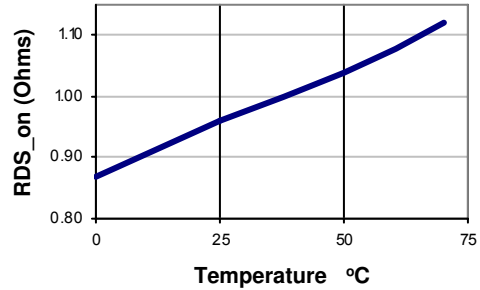

Figure 12: $R_{DS(on)}$ vs. Temperature
Condition: $V_{IN} = 5.0V$; $I_{SW} = 10mA$

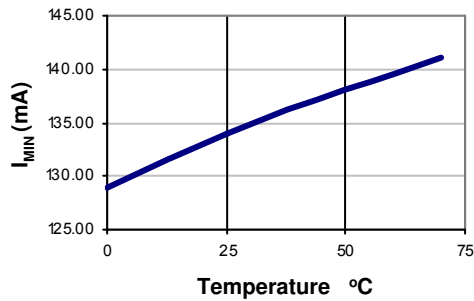

Figure 13: I_{MIN} versus Temperature.
Condition: $V_{IN} = 3.0V$

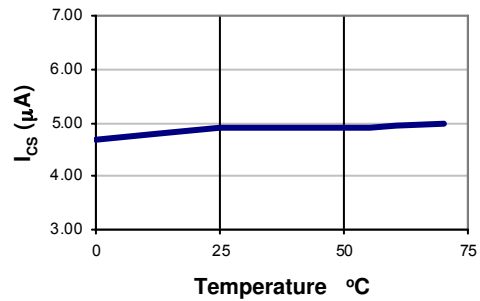

Figure 14: I_{CS} versus Temperature.
Condition: $V_{IN} = 3.0V$

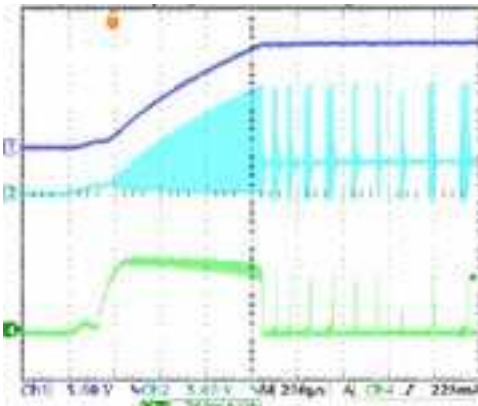
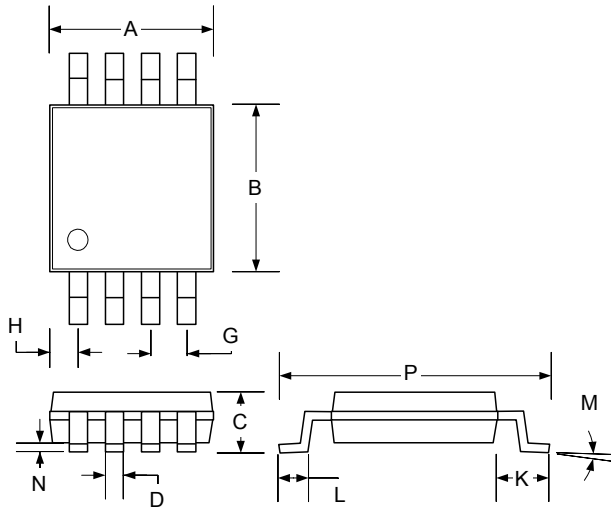

Figure 15: Start-Up Waveforms.
Condition: $V_{IN} = 3.6V$, CH1 = V_{OUT} , CH2 = V_{SW} , CH4 = I_L

PACKAGE DIMENSIONS
DU 8-Pin Miniature Shrink Outline Package (MSOP)

| Dim | MILLIMETERS | | INCHES | |
|-----|-------------|------|-----------|-------|
| | MIN | MAX | MIN | MAX |
| A | 2.85 | 3.05 | .112 | .120 |
| B | 2.90 | 3.10 | .114 | .122 |
| C | — | 1.10 | — | 0.043 |
| D | 0.25 | 0.40 | 0.009 | 0.160 |
| G | 0.65 BSC | | 0.025 BSC | |
| H | 0.38 | 0.64 | 0.015 | 0.025 |
| J | 0.13 | 0.18 | 0.005 | 0.007 |
| K | 0.95 BSC | | 0.037 BSC | |
| L | 0.40 | 0.70 | 0.016 | 0.027 |
| M | 3° | | 3° | |
| N | 0.05 | 0.15 | 0.002 | 0.006 |
| P | 4.75 | 5.05 | 0.187 | 0.198 |

Note: Dimensions do not include mold flash or protrusions; these shall not exceed 0.155mm(0.006") on any side. Lead dimension shall not include solder coverage.



NOTES

PRODUCTION DATA – Information contained in this document is proprietary to Microsemi and is current as of publication date. This document may not be modified in any way without the express written consent of Microsemi. Product processing does not necessarily include testing of all parameters. Microsemi reserves the right to change the configuration and performance of the product and to discontinue product at any time.