

MSARS200S10L
MSARS200S10LR

Features

- passivated mesa structure for very low leakage currents
- Epitaxial structure minimizes forward voltage drop
- Hermetically sealed, low profile ceramic surface mount power package
- Low package inductance
- Very low thermal resistance
- Available as standard polarity (strap-to-anode, MSARS200S10L) and reverse polarity (strap-to-cathode: MSARS200S10LR)

100 Volts
200 Amps

HIGH CURRENT CAPABILITY & LOW VOLTAGE DROP STANDARD RECOVERY RECTIFIER

Maximum Ratings @ 25°C (unless otherwise specified)

DESCRIPTION	SYMBOL	MAX.	UNIT
Peak Repetitive Reverse Voltage	V_{RRM}	100	Volts
Working Peak Reverse Voltage	V_{RWM}	100	Volts
DC Blocking Voltage	V_R	100	Volts
Average Rectified Forward Current, $T_c \leq 125^\circ\text{C}$	$I_{F(ave)}$	200	Amps
derating, forward current, $T_c \geq 125^\circ\text{C}$	di_F/dT	4	Amps/ $^\circ\text{C}$
Nonrepetitive Peak Surge Current, $t_p = 8.3$ ms, half-sinewave	I_{FSM}	750	Amps
Junction Temperature Range	T_j	-55 to +200	$^\circ\text{C}$
Storage Temperature Range	T_{stg}	-55 to +200	$^\circ\text{C}$
Thermal Resistance, Junction to Case:			
	MSARS200S10L	0.20	$^\circ\text{C/W}$
	MSARS200S10LR	0.35	

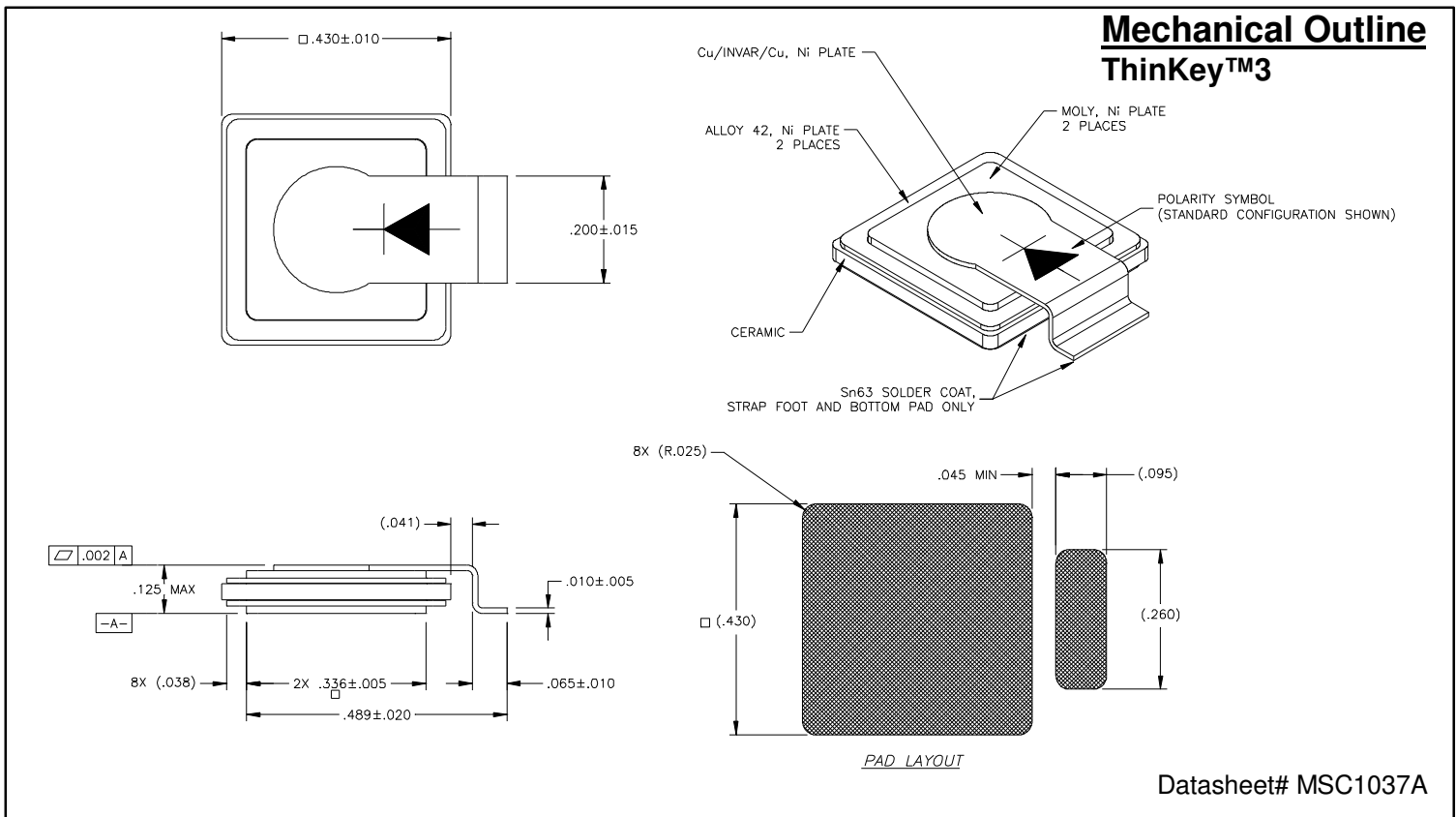

MSARS200S10L
MSARS200S10LR

Electrical Parameters

DESCRIPTION	SYMBOL	CONDITIONS	MIN	TYP.	MAX	UNIT
Reverse (Leakage) Current	IR ₂₅	VR= 100 Vdc, Tc= 25°C	-	.3	25	μA
	IR ₁₀₀	VR= 100 Vdc, Tc= 100°C	-	5	-	μA
	IR ₁₂₅	VR= 100 Vdc, Tc= 125°C	-	15	750	μA
Forward Voltage pulse test, pw= 300 μs d/c≤ 2%	VFa ₂₅	IF= 50 mA, Tc= 25°C		615	-	mV
	VFb ₂₅	IF= 100 mA, Tc= 25°C		640	-	mV
	VFc ₂₅	IF= 500 mA, Tc= 25°C		700	-	mV
	VFa ₁₂₅	IF= 50 mA, Tc= 125°C		440	-	mV
	VFb ₁₂₅	IF= 100 mA, Tc= 125°C		470	-	mV
	VFc ₁₂₅	IF= 500 mA, Tc= 125°C		540	-	mV
	VFa ₋₅₅	IF= 50 mA, Tc= -55°C		740	-	mV
	VFb ₋₅₅	IF= 100 mA, Tc= -55°C		760	-	mV
	VFc ₋₅₅	IF= 500 mA, Tc= -55°C		800	-	mV
	VF1	IF= 5 A, Tc= 25°C		775	825	mV
	VF2	IF= 10 A, Tc= 25°C		800	-	mV
	VF3	IF= 25 A, Tc= 25°C		835	890	mV
	VF4	IF= 50 A, Tc= 25°C		860	925	mV
	VF5	IF= 100 A, Tc= 25°C		890	960	mV
	VF6	IF= 150 A, Tc= 25°C		940		
	VF7	IF= 200 A, Tc= 25°C		970		
	VF8	IF= 250 A, Tc= 25°C		1000		
	VF9	IF= 300 A, Tc= 25°C		1035		
	VF10	IF= 5 A, Tc= -55°C		875	925	mV
	VF11	IF= 10 A, Tc= -55°C		895	-	mV
VF12	IF= 25 A, Tc= -55°C		920	980	mV	
VF13	IF= 50 A, Tc= -55°C		945	1020	mV	
VF14	IF= 100 A, Tc= -55°C		970	1050	mV	
VF16	IF= 10 A, Tc= 125°C		670	-	mV	
VF17	IF= 25 A, Tc= 125°C		715	775	mV	
VF18	IF= 50 A, Tc= 125°C		745	820	mV	
VF19	IF= 100 A, Tc= 125°C		780	850	mV	
Junction Capacitance	Cj1	VR= 10 Vdc		1700	2500	pF
Breakdown Voltage	BVR	IR= 500 μA, Tc= 25°C	100	125	n/a	V
Reverse Recovery Time	trr	IF= .5 A, IR= 1 A, IRR= .25 A		.6	2	μs