

Features

- Electronic Frequency Control
- High Doppler Sensitivity Levels
- Low AM and FM Noise Levels
- Direction-of-Motion Sensing
- Compact Size
- Pulsed Transceivers Available



Applications

- FM Doppler Radar Systems
- Altimeters
- Police Radars
- Intrusion Alarm Systems
- Traffic Control Systems
- Automotive Collision Avoidance Systems

Description

Microsemi's voltage controlled transceivers provide affordable frequency-modulated microwave power at fixed frequencies. The varactor tuning of the transceiver permits carrier frequency modulation for ranging information. These are CW transceivers; pulsed microwave transceivers are available on request.

Specifications @ 25 °C

Model Number	Frequency (GHz) ¹	Min. Output Power (mW)	Frequency Drift/ Temperature (KHz/°C)	Nominal Sensitivity (dBc)	Min. Electronic Tuning Range (MHz)	Tuning Voltage (V _{DC})	Operating Voltage (V _{DC})	Typ. Operating Current (mA)
<i>X Band Voltage Controlled Transceivers</i>								
MO87127-1	10.30	10	400	-110	40	+1 to +20	+8 to +10	200
MO87127-2	10.30	20	400	-110	40	+1 to +20	+8 to +10	600
MO87127-3	10.30	35	400	-110	40	+1 to +20	+8 to +10	600
<i>K Band Voltage Controlled Transceivers</i>								
MO9071	24.125	5	1000	-90	50	+1 to +20	5	150
MO9072 ²	24.125	5	1000	-90	50	+1 to +20	5	150
MO87849	24.125	5	500	-95	150	+0.5 to +20	+5 to +8	400
MO87930	24.125	5 to 10	500	-95	350	0 to +9	+5 to +8	400
<i>Ka Band Voltage Controlled Transceivers</i>								
MO9410-1	35.5 ± 0.1	7.5	1000	-90	100	+1 to +20	3.5–6.0	350
MO9410-2	34.7 ± 0.1	7.5	1000	-90	100	+1 to +20	3.5–6.0	350
MO9410-3	33.8 ± 0.1	7.5	1000	-90	100	+1 to +20	3.5–6.0	350

1. All X Band transceivers have built-in circulators.
 2. M09072 has dual IF output.
- Other frequencies and power levels available upon request.

Operating temperature is -30°C to +70°C.
Storage temperature is -40°C to +85°C.

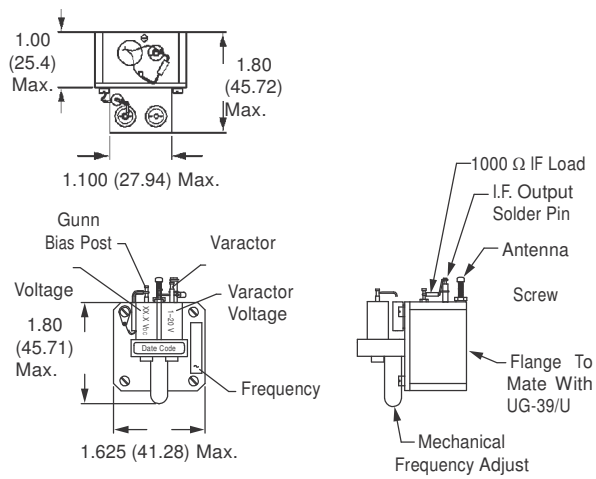
MO87127-1, 2, 3

Dimensions are in inches.

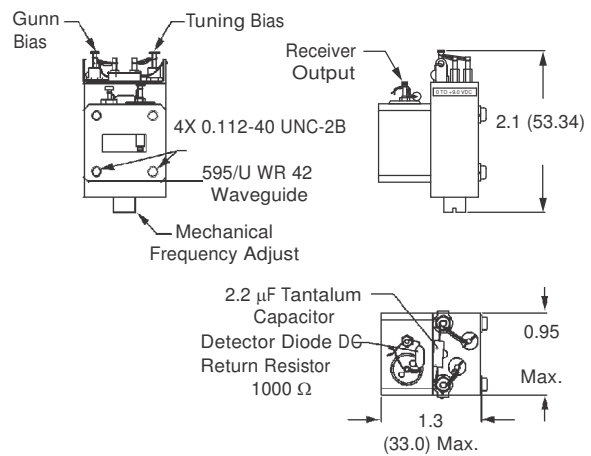
MO87930, MO87849

Dimensions are in inches.

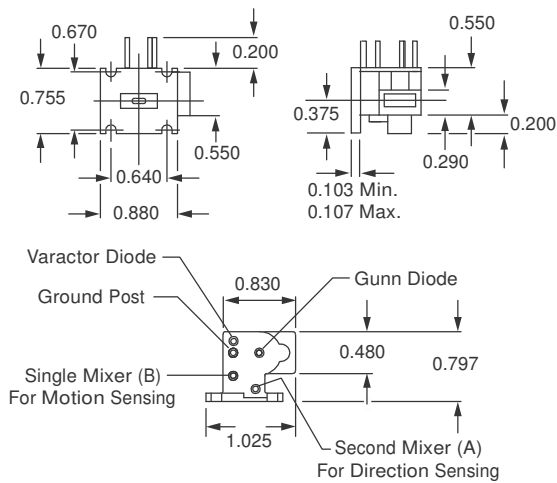
MO9071, MO9072

Dimensions are in inches.

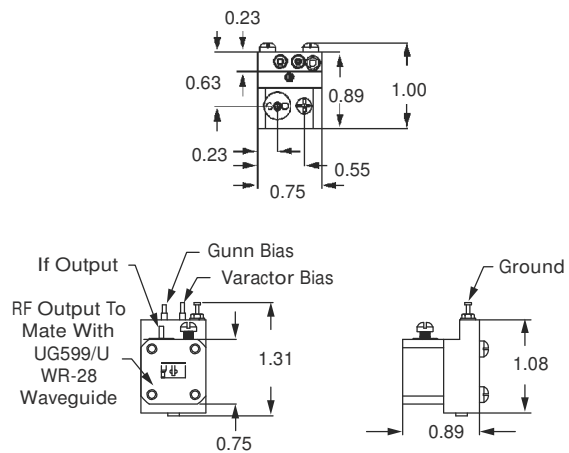
MO9410-1, 2, 3

Dimensions are in inches.