

**DESCRIPTION**

Microsemi's LX1692F is a cost reduced, third generation CCFL (Cold Cathode Fluorescent Lamp) controller. The integrated controller is optimized to drive CCFL's using resonant full bridge inverter topology.

Resonant full bridge topology provides near sinusoidal waveforms over a wide supply voltage range in order to maximize the life of CCFL lamps, control EMI emissions, and maximize efficiency.

The LX1692F includes safety features that limit the transformer secondary voltage and protect against fault conditions which include open lamp, and broken lamp faults.

The LX1692F regulates the CCFL brightness in three ways: analog dimming, digital dimming, or combined analog and digital dimming methods simultaneously to achieve the widest dimming range (> 60 to 1).

The LX1692F can accept a brightness control signal that is either an analog voltage or a low frequency PWM.

The LX1692F also features integrated gate drivers for the four external power MOSFETs.

An integrated 4V LDO powering all internal control circuitry greatly simplifies supply voltage requirements.

The LX1692F is available in either a 20-Pin TSSOP or SOIC package.

**IMPORTANT:** For the most current data, consult MICROSEMI's website: <http://www.microsemi.com>  
Protected by U.S. Patents: 5,615,093; 5,923,129; 5,930,121; 6,198,234; 7,112,929; Patents Pending

**KEY FEATURES**

- Low Stress to Transformers
- Wide Dimming Range
  - Analog Dimming: > 3 to 1
  - Digital Dimming : > 20 to 1
  - Combined: > 60 to 1
- Programmable Burst Dimming Frequency
- Programmable Time-Out Protection
- Fixed Operating Frequency
- Open-Lamp Voltage Protection
- Soft Rise/Fall Burst Dimming Control
- 3% Tolerance Brightness Reference Voltage

**BENEFITS**

- Even Display Light Distribution
- Longer Lamp Life with Optimized Lamp Current Amplitude
- Reduced Operating Voltage Lowers Corona Discharge and Prolongs Inverter Life
- High "Nits / Watt" Efficiency Makes Less Heat and Brighter Displays

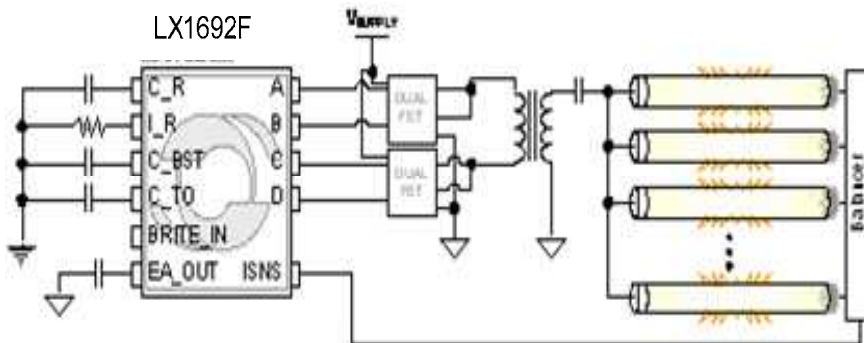
**PRODUCT HIGHLIGHT**

**APPLICATIONS**

- LCD TV
- LCD Monitor

**PACKAGE ORDER INFO**

T <sub>A</sub> (°C)	PW	Plastic TSSOP 20-Pin	DW	Plastic SOIC 20-Pin
	-20 to +85		RoHS Compliant / Pb-free <b>LX1692FIPW</b>	

Note: Available in Tape & Reel. Append the letters "TR" to the part number. (i.e. LX1692FIPW-TR)



**Microsemi**<sup>®</sup>

## INFORMATION

*Thank you for your interest in Microsemi<sup>®</sup> Analog Mixed Signal products.*

The full data sheet for this device contains proprietary information.

To obtain a copy, please contact your local Microsemi sales representative. The name of your local representative can be obtained at the following link

<http://www.microsemi.com/contact/contactfind.asp>

**or**

Contact us directly by sending an email to:

[IPGdatasheets@microsemi.com](mailto:IPGdatasheets@microsemi.com)

Be sure to specify the data sheet you are requesting and include your company name and contact information and or vcard.

*We look forward to hearing from you.*