

DESCRIPTION

The LSP series of Enhanced Performance Surface Mount (EPSM) PIN diodes offers the circuit designer a higher level of quality in a commercially priced package. Choose from LSP1000, LSP1004, and LSP1008 for switching applications, LSP1002, LSP1005, LSP1010 and LSP1011 for low distortion attenuation from VHF through 5 GHz. They are available in a host of configurations (see configuration table for internal wiring.) The LSP products are supplied with a RoHS compliant gold finish.

Other configurations are available - consult factory for details. When ordering specify configuration (example: LSP1004-454-4 is a common cathode dual pin).

KEY FEATURES

- Low Cost
- High Performance
- Surface Mount
- Available on Tape
- Multiple Configurations to Choose From
- RoHS Compliant¹

APPLICATIONS

Specify EPSM package style 450A or 454. For 3 terminal style 454, refer to configuration page. Example: LSP1001-454-4 is a common cathode pair of PIN diodes for broadband switching applications; for the 2 terminal style 450A, refer to the outline dimension table.

Example: LSP1001-450A is a single device with a 0.075 x 0.050 outline.

APPLICATIONS/BENEFITS

- High Performance Wireless Surface Mount Options for GSM, TAGS, WANS, PCS
- Wideband Switching
- Broadband Attenuators
- Phase Shifters
- Broadband Limiters

**ABSOLUTE MAXIMUM RATINGS AT 25° C
(UNLESS OTHERWISE SPECIFIED)**

Rating	Symbol	Value	Unit
Maximum Leakage Current @80% of Minimum Rated V_B	I_R	50	nA
Storage Temperature	T_{STG}	-65 to +125	°C
Operating Temperature	T_{OP}	-65 to +125	°C
Power Dissipation	P_D	500	mW
Forward Current (1uS Pulse)	I_F	1	A

IMPORTANT: For the most current data, consult our website: www.MICROSEMI.com
Specifications are subject to change, consult factory for the latest information.

 These devices are ESD sensitive and must be handled using ESD precautions.

¹ The EPSM products are supplied with a RoHS complaint Gold finish.

EPSM PIN Diodes
ELECTRICAL PARAMETERS @ 25°C (unless otherwise specified)

Model Number	V _B (V) I _R =10μA (Min)	C _T (pF) ¹ @V _R (Max)	V _R (V)	R _S (Ohms) ² @I _F (Max)	I _F (mA)	T _L (nS) ³ (Typ)	Application
LSP1000	35	0.28	5	2.5	5	80	Switch
LSP1002	100	0.32	50	4.0	100	1500	Attenuator
LSP1004	35	0.75	20	0.6	10	150	Switch
LSP1011	200	0.35	50	2.0	100	2000	Attenuator
LSP1012	20	0.35	10	1.8	10	5	Limiter

Notes

1. Capacitance (C_T) is measured at f = 1 MHz
2. Series Resistance (R_S) is measured at f = 100 MHz
 - a. The LSP1012 is measured at f = 1GHz
3. Carrier Lifetime (T_L) is measured at I_F = 10 mA, I_R = 6 mA

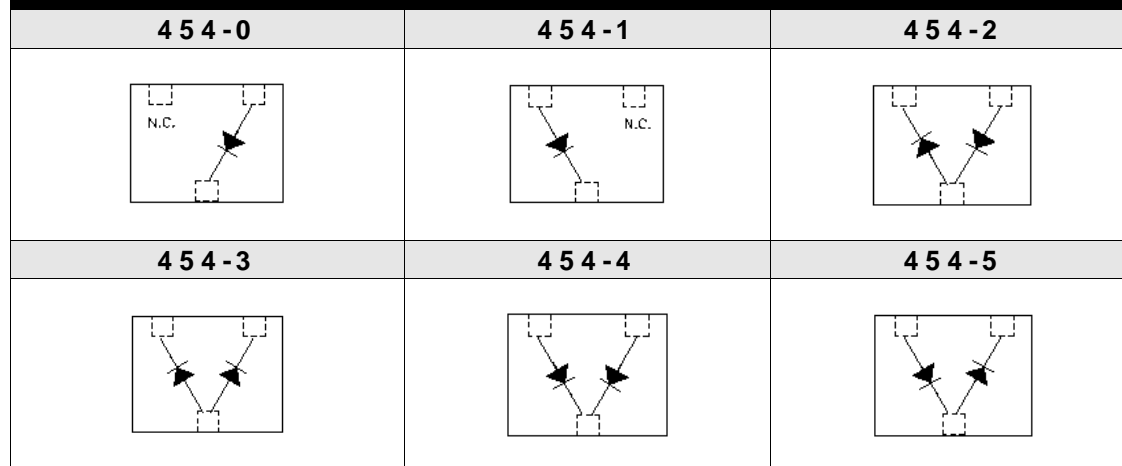
TYPICAL PINOUT FOR 454-X PACKAGE STYLE

MECHANICAL OPTIONS

EPSM products are available in a broad range of mechanical configurations. The standard package style is the 450 series. This series has several sizes available to accommodate the internal chip configurations. The 450A is the most common configuration for single diode applications. The 454 series package style is a three terminal configuration designed to accommodate 2 chip for 'T' and common anode/cathode designs. With uniform 'flat-top' construction, the 450 series of EPSM products are ideally suited for tape and reel / automated assembly.

The 150 series of EPSM products have a 'glob-top' construction and are traditionally used in smaller volume applications.

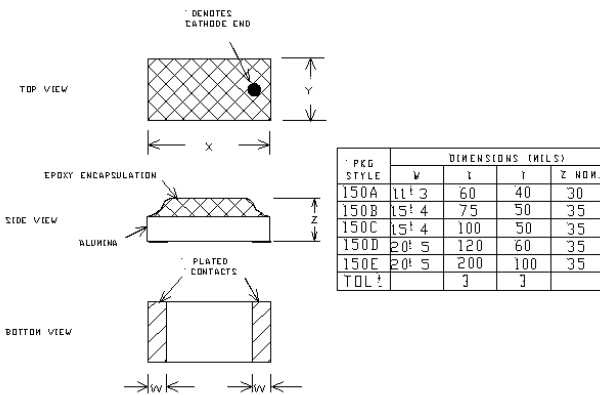
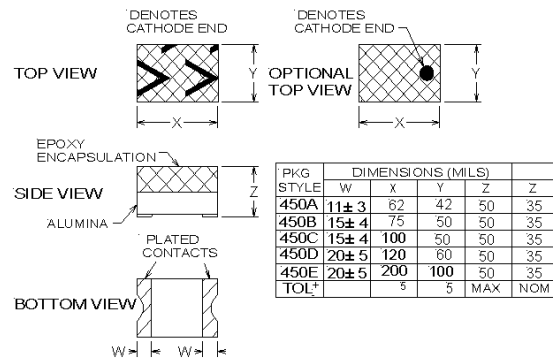
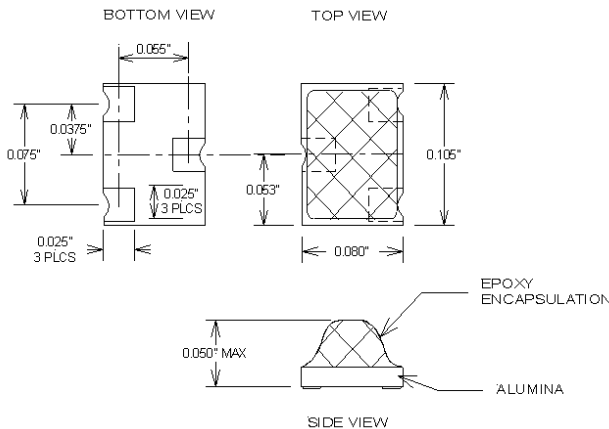
PACKAGE STYLE 150X

PACKAGE STYE 450X

PACKAGE STYLE 154

PACKAGE STYPE 454
