

DESCRIPTION

The LX8221 family of dual output linear regulators provide for the selection of either fixed or adjustable output voltages, and combine low dropout operation, fast transient performance, tight output voltage accuracy, and ultra-low ground current within a very small package footprint.

The PMOS output transistor allows for an ultra-low dropout characteristic (e.g., typically less than 175mV at 100mA). The individual regulators can be powered from either separate supply voltages or the same supply voltage between 2.8V to 6V allowing for maximum system flexibility.

An optional ceramic or tantalum type capacitor may be connected to each Bypass pin separately to improve performance in critical low-noise applications.

Overall regulator efficiency has been improved with a minimized operating ground current (typical < 140µA per regulator). Further, this ground current is virtually eliminated in shutdown mode (typical < 1µA).

Other safety features include channel independent Thermal and Short Circuit Current protection.

Separate Enable pins allow each regulator to be switched on and off independently by applying a TTL logic level control signal to the Enable pin further enhancing system level power management.

These features combined with a small footprint (i.e., 10-pin MSOP package) make the LX8221 especially useful for battery-operated equipment such as cellular telephones, laptop computers and PDA equipment.

KEY FEATURES

- Compact Regulators With Two 150mA Outputs
- Dropout Voltage Typically 175mV @ 100mA
- Ultra Low Shutdown Current Typically Less Than 1µA
- Output Trimmed to 0.5%
- Small MSOP-10 Package
- Over Current & Temperature Protection
- Stable with Ceramic or Tantalum Capacitors

APPLICATIONS

- Battery Operated Systems
- Laptop, Notebook and PDA's
- Cellular Telephones/Pagers
- Instrumentation
- Linear Post Regulators for SMPS

IMPORTANT: For the most current data, consult *Microsemi's* website: <http://www.microsemi.com>

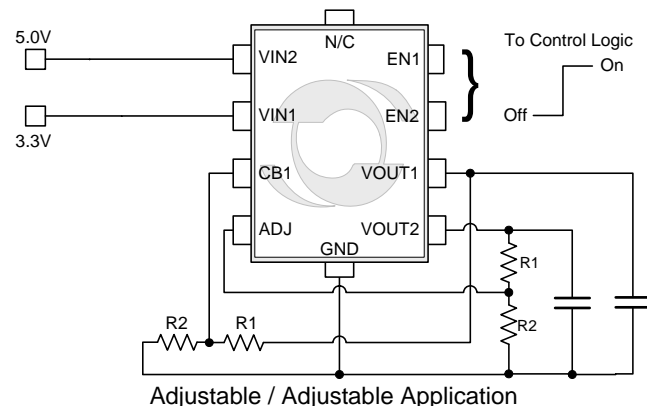
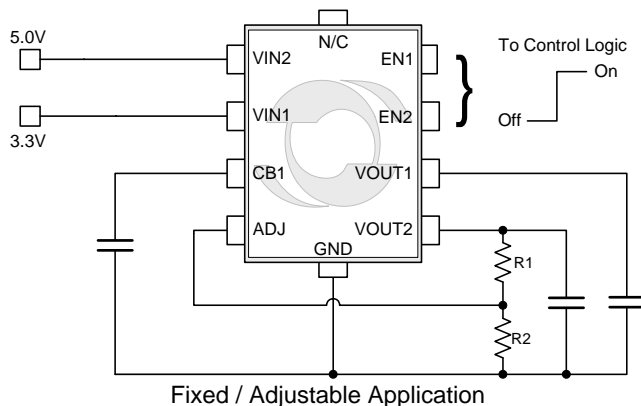
PRODUCT HIGHLIGHT

PACKAGE ORDER INFO

T _A (°C)	VOUT1	VOUT2	DU	Plastic MSOP 10-Pin RoHS Compliant / Pb-free Transition D/C: 0432	Package Marking
-40 to 85	Adjustable	Adjustable		LX8221AIDU	8221 AIDU LX
-40 to 85	2.5V	Adjustable		LX8221BIDU	8221 BIDU LX
-40 to 85	2.7V	Adjustable		LX8221DIDU	8221 DIDU LX
-40 to 85	3.0V	Adjustable		LX8221GIDU	8221 GIDU LX

Contact Microsemi for additional / available options
 Note: Available in Tape & Reel. Append the letters "TR" to the part number. (i.e. LX8221AIDU-TR)

ABSOLUTE MAXIMUM RATINGS

Input Voltage (VIN1, VIN2).....	-0.3V to +7V
Output Current (I _{OUT1} , I _{OUT2}).....	150mA
Operating Temperature Range	-40 to +125 °C
Maximum Junction Temperature (T _J)	150 °C
Storage Temperature (T _J)	-65 to +150 °C
Peak Package Solder Reflow Temp. (40 second max. exposure).....	260°C (+0, -5)

Note: Exceeding these ratings could cause damage to the device. All voltages are with respect to Ground. Currents are positive into, negative out of specified terminal.

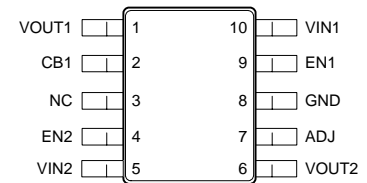
PACKAGE PIN OUT

DU PACKAGE
(Top View)

"NC" = No Internal Connection

RoHS / Pb-free 100% Matte Tin Lead Finish

THERMAL DATA

DU Plastic MSOP 8-Pin

THERMAL RESISTANCE-JUNCTION TO AMBIENT, θ_{JA}	206°C/W
---	----------------

Junction Temperature Calculation: $T_J = T_A + (P_D \times \theta_{JC})$.

The θ_{JA} numbers are guidelines for the thermal performance of the device/pc-board system. All of the above assume no ambient airflow.

FRONT MARKING

8221
xIDU
LX

x = Voltage Combination
i.e. A = Adj/Adj

FUNCTIONAL PIN DESCRIPTION

PIN NAME	DESCRIPTION
VIN1/VIN2	Unregulated input supply voltage
GND	Ground Pin
EN1/EN2	Enable control input: Logic high = Enable; logic low or open = Shutdown
CB1	Reference bypass input. Adding an additional external capacitor reduces output noise.
VOUT1/VOUT2	Regulated output voltage. Regulator stability is achieved with external capacitor of 1 μ F
ADJ (1, 2)	Adjust pin. Connect a resistor divider to this pin to establish preferred output voltage.

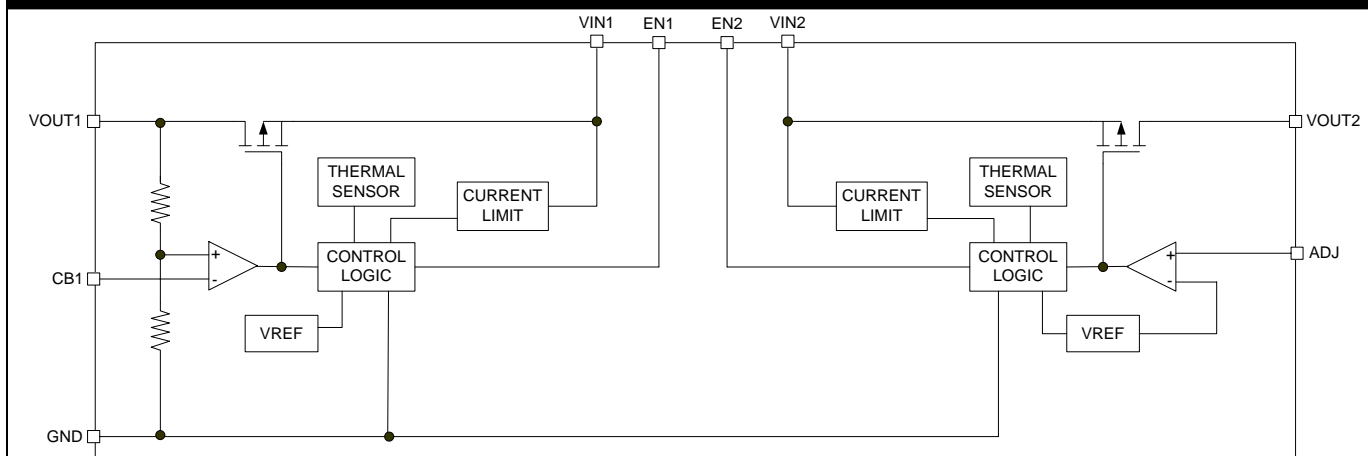
BLOCK DIAGRAM

RECOMMENDED OPERATING CONDITIONS

Parameter	Symbol	LX8221			Units
		Min	Typ	Max	
Input Operating Voltage Range (Note 1)	V _{IN1} , V _{IN2}	2.5		6	V
Enable Input Voltage Range	EN1/2			V _{IN} + 0.3V	V
Continuous Output Current Range	I _{OUT1} , I _{OUT1}		150		mA
Input Capacitor (V _{IN} to GND)	C _{IN}	1.0*			μF
Output Capacitor (V _{OUT} to GND)	C _{OUT}	1.0*	2.2		μF

Note 1: The minimum V_{IN} has to meet two conditions V_{IN} ≥ 2.5V and V_{IN} ≥ V_{OUT} + V_{DROPOUT}, at high line voltage conditions output current may be limited to less than 150mA due to the power dissipation.

* Size your output capacitor to meet the transient loading requirement. If you have a very dynamic load, a lower ESR and larger value capacitor will improve the response to these load steps.

ELECTRICAL CHARACTERISTICS

Unless otherwise specified, the following specifications apply over the operating ambient temperature -40°C ≤ T_A ≤ 85°C except where otherwise noted. Test conditions: V_{IN} = V_{OUT} + 0.5V; I_{OUT} = 10mA; C_{IN} = 1μF; C_{OUT} = 1μF; T_J = T_A using low duty cycle pulse testing methods.

Parameter	Symbol	Test Conditions	LX8221			Units
			Min	Typ	Max	
Output Voltage (2.5, 2.7, 3.0, ADJ)	V _{OUT1/2}	T _J = 25°C	-1		1	%
		0mA ≤ I _{OUT1/2} ≤ 100mA, (V _{OUT1/2} + 0.5V) ≤ V _{IN} ≤ 6V	-2.5		2.5	
Adjust Reference Voltage	V _{ADJ}	T _J = 25°C	1.163	1.175	1.187	V
		0mA ≤ I _{OUT1/2} ≤ 100mA, 2.85V ≤ V _{IN} ≤ 6V	1.140		1.210	
Line Regulation $\left(\frac{\Delta V_O}{\Delta V_{IN}}\right)$	V _{RV}	(V _{OUT1/2} + 0.5V) ≤ V _{IN} ≤ 5V, I _{OUT1/2} = 0.1mA		0.04	0.15	%/V
Load Regulation $\left(\frac{\Delta V_O}{\Delta I_O}\right)$	V _{RL}	T _J = 25°C, 0.5mA ≤ I _{OUT1/2} ≤ 150mA		0.5		%V _{NOM}
		0.5mA ≤ I _{OUT1/2} ≤ 100mA			1.5	
Dropout Voltage (V _{IN} - V _O) (Note 2)	V _{DO}	I _{LOAD1/2} = 1mA, ΔV _O = -1%			0.050	V
		I _{LOAD1/2} = 50mA, ΔV _O = -1%			0.175	
		I _{LOAD1/2} = 100mA, ΔV _O = -1%		0.175	0.3	
		I _{LOAD1/2} = 150mA, ΔV _O = -1%		0.25	0.4	
Ground Pin Current	I _{GND}	EN1 = High, EN2 = High		280	440	μA
	I _{STBY}	EN1 = Low, EN2 = Low			1	
Adjust Input Bias Current	I _{ADJ}	V _{ADJ} = 1.25V			100	nA
Enable Pin Current	I _{EN}	V _{EN1/2} = V _{IN}			100	nA
Enable Threshold	V _{EN(IH)}		2.0			V
	V _{EN(IL)}				0.4	
Short Circuit Current Limit	I _{OUT(SC)}	V _{OUT1} = 0V, V _{OUT2} = 0V		400		mA
Power Supply Rejection Ratio	PSRR	T _J = 25°C, f = 120Hz		50		dB
Output Noise	e _N	T _J = 25°C, C _{OUT} = 10μF, C _{BYPASS} = 470pF		50		μV
Thermal Shutdown Temperature	T _{SD}			170		°C

Note 2: Dropout voltage is defined as the input to output differential at which the output voltage drops 1% below the nominal value. Dropout voltage specification applies only to output voltages greater than 2.8V. For output voltages below 2.8V, the dropout voltage is nothing but the input to output differential, since the minimum input voltage is 2.8V.

APPLICATIONS**Description**

The LX8221 family of LDO linear regulators is available in a 10-pin MSOP Package and provides a cost effective power management solution for battery driven applications. The regulator family includes both fixed/adjustable and adjustable/adjustable output voltage versions. The internal PMOS power device provides low dropout regulation with a fast line and load transient response. It also includes internal current limiting and thermal shutdown circuitry. In this section you will find information about capacitor, thermal, and layout design considerations.

Input Capacitor

To improve load transient response and noise rejection a bypass capacitor is recommended (but it is not required for stability). There are no requirements for the ESR (Equivalent Series Resistor) on the input capacitor, but tolerance and temperature coefficient must be considered when selecting this capacitor to ensure that the capacitor's value will be around 1 μ F over the entire operating temperature range. For the LX8221, a 1 μ F ceramic type capacitor may be connected between both VIN1/2 and ground.

Output Capacitor

The LX8221 uses an internal feedback loop to maintain a constant output voltage. This feedback loop induces a natural phase shift and the amount of phase shift determines the loop's stability. Therefore, like any low-dropout regulator, an output capacitor with low ESR (Equivalent Series Resistance) is required between VOUT and GND to stabilize the internal control loop. A ceramic, tantalum or electrolytic capacitor with a minimum recommended capacitance value of 1.0 μ F and ESR between 5m Ω and 1 Ω will satisfy the stability for the entire operating range.

Optional Bypass Capacitor

The fixed/adjustable voltage version of the LX8221 includes a separate Bypass pin (CB1) for the fixed regulator that allows for further reduction of output noise. If the regulator's output noise performance meets system design specifications without the capacitor, omit it. The bypass capacitor impacts the start up time, which is inversely proportional to the size of bypass capacitor. Further, the bypass capacitor reduces the regulator phase margin. Hence, implementing the bypass capacitor will require the use of a larger output capacitor to maintain the

LDO's stability. The LX8221-x adjustable regulator's output voltage can be externally set by connecting the ADJ pin/s to an external resistor divider (See Figure 1 and 2). The output voltage can be calculated using the formula:

$$V_{OUT} = V_{ADJ} \left(1 + \frac{R_1}{R_2} \right)$$

Enable

The Enable pin allows the LX8221 to be independently turned on and off. The Enable pins are compatible with standard TTL-CMOS levels. A logic zero (0.4V) on the En₁/En₂ pins shuts the LX8221 off and reduces the supply current to less than 1 μ A (typical). Pulling the Enable inputs high (2.0V) causes normal operation to resume. If the Enable feature is not used, this pin can be connected to V_{IN}.

Minimum Load Requirement

Although line regulation is improved with a minimum load of 100 μ A, the LX8221 does not have a minimum load current in order to maintain stability. This is an especially important feature in certain applications.

Temperature Protection

The thermal protection shuts the LX8221 down when the junction temperature exceeds approximately 150°C; there is no appreciable thermal hysteresis.

Short Circuit Current Protection

The LX8221 includes over-current protection, when the output load current exceeds about 400mA. When this occurs, the protection circuit forces the regulator to decrease its output current.

Thermal Consideration

Thermal shutdown protects the integrated circuit from thermal overload caused from a rise in junction temperature during power dissipation. This type of protection is intended for fault protection only and not as a means of current (or, power) limiting during normal application usage. Proper thermal evaluation should be done to ensure that the junction temperature does not exceed its maximum rating. Operating at the maximum T_J of 150°C can impact reliability. Due to variation in individual device electrical characteristics and thermal resistance, the built in thermal overload protection may be activated at power levels slightly above or below the rated dissipation. Power dissipation for each regulator can

APPLICATIONS

be calculated using the following equation:

$$P_D = (V_{IN(MAX)} - V_{OUT(MIN)}) \times I_{OUT(MAX)}$$

(Note: power dissipation resulting from quiescent current is negligible)

For the MSOP package, thermal resistance, θ_{JA} is 206°C/W when mounted on a FR4 copper clad PCB. Junction temperature of the integrated circuit can be calculated using:

$$T_J = T_A + T_{RISE}$$

Where:

$$T_{RISE} = (P_D \times \theta_{JA})$$

Example: Given the following conditions:

- $T_A = 60^\circ\text{C}$
- $V_{IN} = 4.2\text{V}$
- $V_{OUT} = 2.7\text{V}$
- $I_{OUT} = 100\text{mA}$

calculate the *total power dissipation* and *junction temperature*:

Total Power Dissipation:

$$P_D = (4.2\text{V} - 2.7\text{V}) \times 0.1\text{A} = 0.15\text{W}$$

Junction Temperature:

$$T_J = 60^\circ\text{C} + (0.15\text{W} \times 206^\circ\text{C/W}) = 91^\circ\text{C}$$

Layout Consideration:

The layout must be implemented with low impedance paths for V_{IN} , V_{OUT} and Ground by creating sufficiently wide traces to avoid voltage drops and pick up noise. Adding an area of PCB copper to the GND pin (pin 8) will reduce the overall θ_{JA} since it is thermally connected to the device substrate. This will lower the device junction temperature improving overall output voltage accuracy. The input/output capacitors must be placed as close as possible to each voltage regulator output pin.

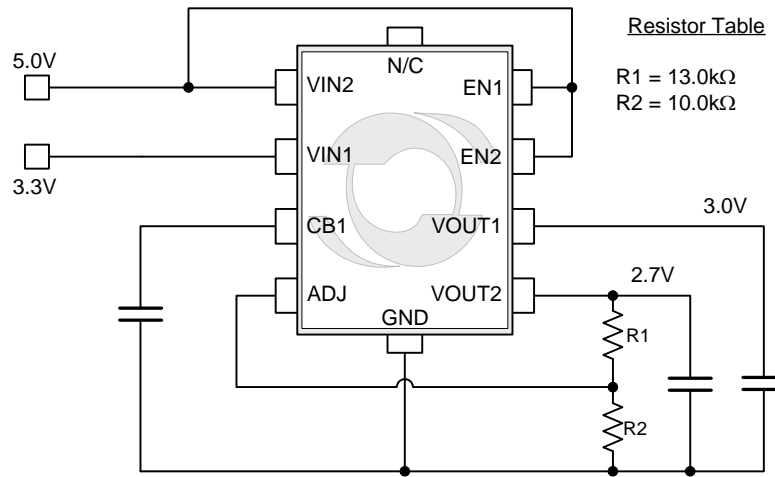
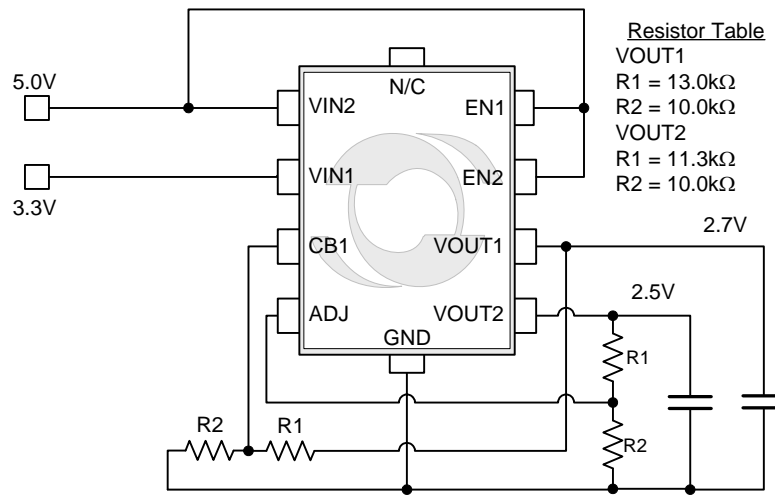
APPLICATION CIRCUITS

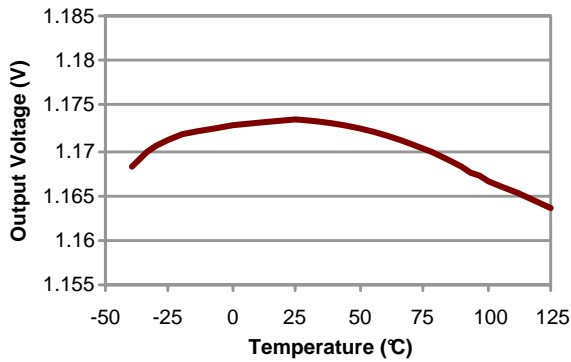
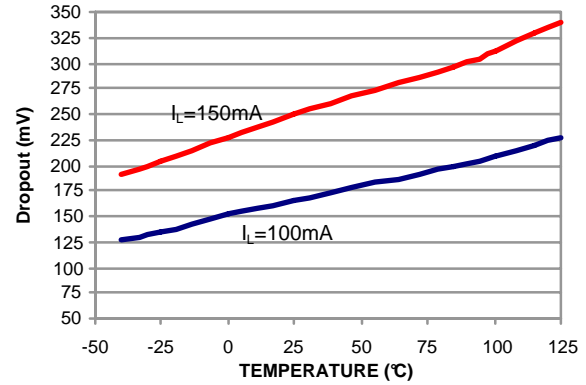
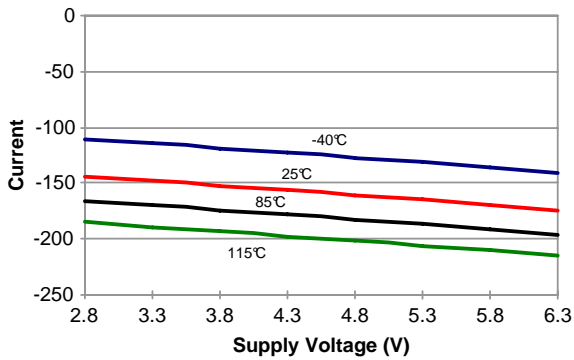
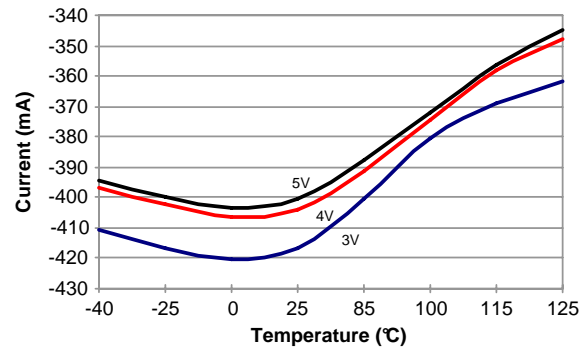
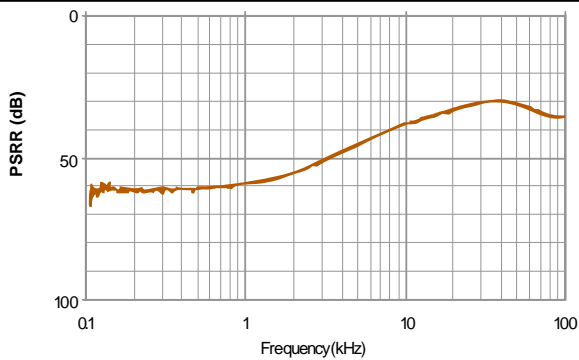
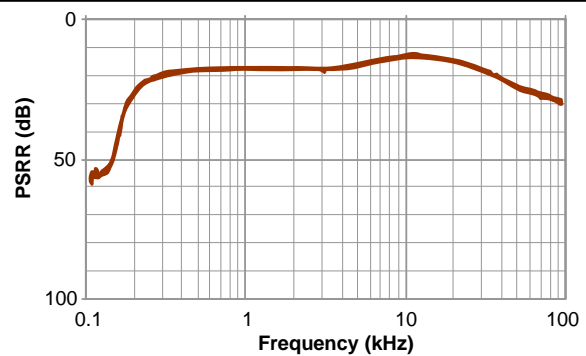
Figure 1 – Fixed / Adjustable Output Application

Figure 2 – Adjustable / Adjustable Output Application

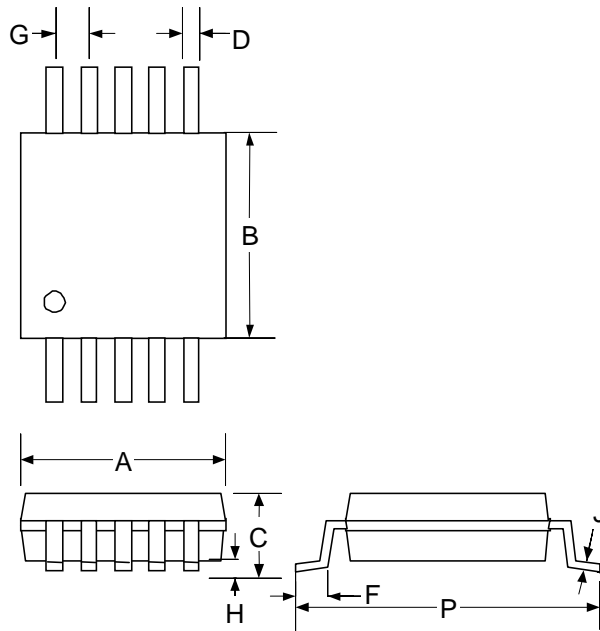
OUTPUT VOLTAGE VS TEMPERATURE

DROPOUT VOLTAGE VS TEMPERATURE

OUTPUT CURRENT VS SUPPLY VOLTAGE

SHORT CIRCUIT CURRENT VS TEMPERATURE

PSRR VS FREQUENCY

PSRR VS FREQUENCY IN DROPOUT

Typical performance characteristics, unless otherwise specified are: $C_{IN} = C_{OUT} = 1\mu\text{F}$, $C_{BY} = 470\text{pF}$, $V_{IN} = V_{OUT} = 2.5\text{V}$, $T_A = 25^\circ\text{C}$, ENABLE is tied to V_{IN} .

PACKAGE DIMENSIONS
DU 10-Pin Plastic MSOP

Dim	MILLIMETERS		INCHES	
	MIN	MAX	MIN	MAX
A	2.85	3.05	0.112	0.120
B	2.90	3.10	0.114	0.122
C	-	1.10	-	0.043
D	0.16	0.31	0.006	0.0124
F	0.40	0.60	0.015	0.023
G	0.50 BSC		0.019 BSC	
H	0.050	0.150	0.002	0.006
J	0.10	-	0.004	-
P	4.75	5.05	0.187	0.198
*LC	-	0.10	-	0.004

*Lead Coplanarity

Note: Dimensions do not include mold flash or protrusions; these shall not exceed 0.155mm(.006") on any side. Lead dimension shall not include solder coverage.



Microsemi[®]

LX8221

Dual 150mA CMOS Low Dropout Regulator

PRODUCTION DATA SHEET

NOTES

PRODUCTION DATA – Information contained in this document is proprietary to Microsemi and is current as of publication date. This document may not be modified in any way without the express written consent of Microsemi. Product processing does not necessarily include testing of all parameters. Microsemi reserves the right to change the configuration and performance of the product and to discontinue product at any time.