

MRF5812, R1, R2
MRF5812G, R1, R2

* G Denotes RoHS Compliant, Pb free Terminal Finish

Features

- Low Noise - 2.5 dB @ 500 MHz
 - Associated Gain = 15.5 dB @ 500 MHz
 - Ftau - 5.0 GHz @ 10v, 75mA
 - Cost Effective SO-8 package
-

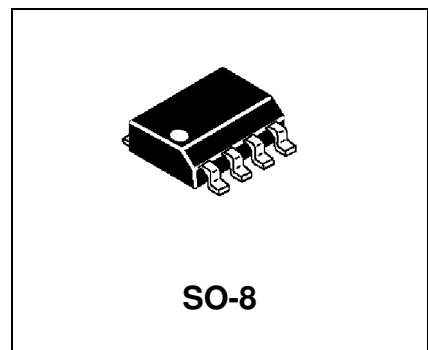

R1 suffix–Tape and Reel, 500 units
R2 suffix–Tape and Reel, 2500 units

DESCRIPTION: Designed for high current, low power, low noise, amplifiers up to 1.0 GHz.

ABSOLUTE MAXIMUM RATINGS (T_{case} = 25°C)

Symbol	Parameter	Value	Unit
V _{CEO}	Collector-Emitter Voltage	15	Vdc
V _{CBO}	Collector-Base Voltage	30	Vdc
V _{EBO}	Emitter-Base Voltage	2.5	Vdc
I _C	Collector Current	200	mA

Thermal Data

P _D	Total Device Dissipation @ TC = 25°C Derate above 25°C	1.25 10	Watts mW/ °C
----------------	---	------------	-----------------

ELECTRICAL SPECIFICATIONS (T_{case} = 25°C)
**STATIC
(off)**

Symbol	Test Conditions	Value			Unit
		Min.	Typ.	Max.	
BVCEO	Collector-Emitter Breakdown Voltage (I _C = 5.0 mA _{dc} , I _B = 0)	15	-	-	V _{dc}
BVCBO	Collector-Base Breakdown Voltage (I _C = 1.0 mA _{dc} , I _E = 0)	30	-	-	V _{dc}
BVEBO	Emitter-Base Breakdown Voltage (I _E = 0.1 mA _{dc} , I _C = 0)	2.5	-	-	V _{dc}
ICBO	Collector Cutoff Current (V _{CB} = 15 V _{dc} , V _{BE} = 0 V _{dc})	-	-	0.1	mA
IEBO	Emitter Cutoff Current (V _{CE} = 2.0 V _{dc} , V _{BE} = 0 V _{dc})	-	-	0.1	mA

(on)

HFE	DC Current Gain (I _C = 50 mA _{dc} , V _{CE} = 5.0 V _{dc})	50		200	
-----	--	----	--	-----	--

DYNAMIC

Symbol	Test Conditions	Value			Unit
		Min.	Typ.	Max.	
COB	Output Capacitance (V _{CB} = 10 V _{dc} , I _E = 0, f = 1.0 MHz)	-	1.4	2.0	pF
F _{tau}	Current-Gain Bandwidth Product (I _C = 75 mA _{dc} , V _{CE} = 10 V _{dc} , f = 1.0 GHz)	-	5.0	-	GHz

FUNCTIONAL

Symbol	Test Conditions	Value			Unit
		Min.	Typ.	Max.	
NFmin	Minimum Noise Figure (IC = 50 mAdc, VCE = 10 Vdc, f = 500 MHz)	-	2.0	3.0	dB
G_{NF}	Power Gain @ Nfmin (IC = 50 mAdc, VCE = 10 Vdc, f = 500 MHz)	13	15.5		dB
$G_{U\max}$	Maximum Unilateral Gain (1) IC = 50 mAdc, VCE = 10 Vdc, f = 500 MHz	-	17.8	-	dB
MSG	Maximum Stable Gain IC = 50 mAdc, VCE = 10 Vdc, f = 500 MHz	-	20	-	dB
$ S_{21} ^2$	Insertion Gain IC = 50 mAdc, VCE = 10 Vdc, f = 500 MHz	-	15	-	dB

Table 1. Common Emitter S-Parameters, @ VCE = 10 V, IC = 50 mA

f (MHz)	S11		S21		S12		S22	
	S11	$\angle \phi$	S21	$\angle \phi$	S12	$\angle \phi$	S22	$\angle \phi$
100	.579	-141	24	107	.024	49	.397	-76
300	.593	-173	8.93	85	.045	66	.233	-103
500	.598	175	5.14	74	.066	69	.248	-110
1000	.592	158	2.64	52	.132	72	.347	-119
2000	.615	115	1.55	20	.310	63	.531	-141
3000	.691	72	1.10	-5	.518	41	.648	-172

MRF5812, R1, R2 MRF5812G, R1, R2

Package	Device	Type	GPE Freq (MHz)	Pout (watts)	GPE (dB)	Efficiency (%)	GPE VCC	BVCEO	IC max (mA)
SO-8	MRF4427, R2	NPN	175	0.15	18	60	12	20	400
TO-39	2N4427	NPN	175	1	10	50	12	20	400
POWER MACRO	MRF553	NPN	175	1.5	11.5	60	12.5	16	500
POWER MACRO	MRF553T	NPN	175	1.5	11.5	50	12.5	16	500
TO-39	MRF607	NPN	175	1.75	11.5	50	12.5	16	330
TO-39	2N6255	NPN	175	3	7.8	50	12.5	18	1000
TO-72	2N5179	NPN	200		20		6	12	50
MACRO X	MRF559	NPN	512	0.5	10	65	7.5	16	150
MACRO X	MRF559	NPN	512	0.5	13	60	12.5	16	150
TO-39	2N3866A	NPN	400	1	10	45	28	30	400
SO-8	MRF3866, R1, R2	NPN	400	1	10	45	28	30	400
POWER MACRO	MRF555	NPN	470	1.5	11	50	12.5	16	400
POWER MACRO	MRF555T	NPN	470	1.5	11	50	12.5	16	400
MACRO X	MRF559	NPN	870	0.5	6.5	70	7.5	16	150
MACRO X	MRF559	NPN	870	0.5	9.5	65	12.5	16	150
SO-8	MRF8372, R1, R2	NPN	870	0.75	8	55	12.5	16	200
POWER MACRO	MRF557	NPN	870	1.5	8	55	12.5	16	400
POWER MACRO	MRF557T	NPN	870	1.5	8	55	12.5	16	400

RF (Low Power PA / General Purpose) Selection Guide

Package	Device	Type	Freq (MHz)	NF (dB)	NF IC (mA)	NF VCE	GNF (dB)	Gu Max (dB)	Ftau (MHz)	Ccb(pF)	BVCEO	IC max (mA)
TO-39	2N5109	NPN	200	3	10	15		12	1200	3.5	20	400
TO-39	MRF5943C	NPN	200	3.4	30	15		11.4	1000		30	400
SO-8	MRF5943, R1, R2	NPN	200	3.4	30	15		15	1300		30	400
TO-72	2N5179	NPN	200	4.5	1.5	6		17	900	1	12	50
TO-72	2N2857	NPN	300	5.5	50	6		13	1600	1	15	40
TO-39	MRF517	NPN	300	7.5	50	15		5.5	4600	3	25	150
TO-72	MRF904	NPN	450	1.5	5	6		11	4000	1	15	30
TO-72	2N6304	NPN	450	5	2	5		14	1400	1	15	50
MACRO T	BFR91	NPN	500	1.9	2	5	11	16.5	5000	1	12	35
MACRO T	BFR96	NPN	500	2	10	10		14.5	500	2.6	15	100
SO-8	MRF5812, R1, R2	NPN	500	2	50	10	15.5	17.8	5000		15	200
MACRO X	MRF581A	NPN	500	2	50	10	14	15	5000		15	200
Macro	BFR90	NPN	500	2.4	2	10	15	18	5000	1	15	30
TO-72	BFY90	NPN	500	2.5	2	5		20	1300		15	50
TO-72	MRF914	NPN	500	2.5	5	10		15	4500		12	40
MACRO X	MRF581	NPN	500	2.5	50	10	15	17.8	5000		16	200
TO-39	MRF586	NPN	500	3	90	15	11	14.5	4500	2.2	17	200
MACRO X	MRF951	NPN	1000	1.3	5	6	14	17	8000	0.45	10	100
MACRO X	MRF571	NPN	1000	1.5	10	6	10		8000	1	10	70
MACRO T	BFR91	NPN	1000	2.5	2	5	8	11	5000	1	12	35
MACRO T	BFR90	NPN	1000	3	2	10	10	12.5	5000	1	15	30
TO-39	MRF545	PNP						14	1400	2	70	400
TO-39	MRF544	NPN						13.5	1500		70	400

RF (LNA / General Purpose) Selection Guide

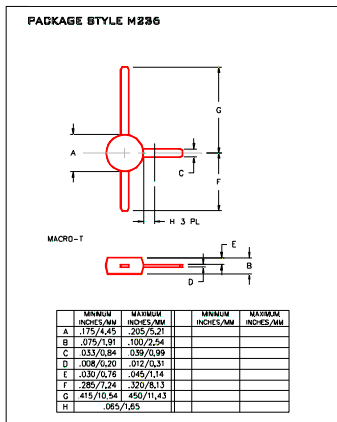

Macro T

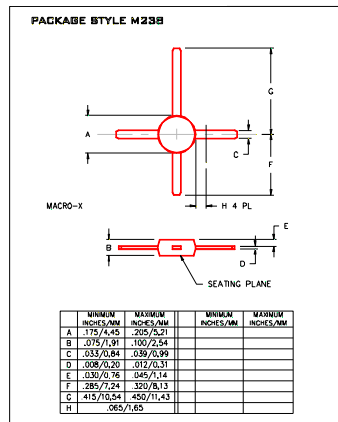

Macro X

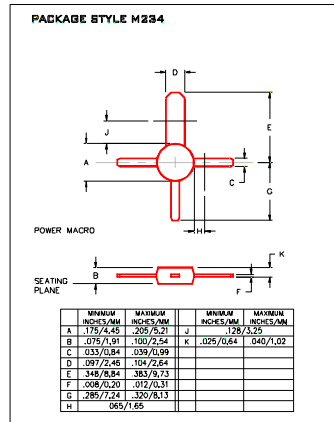

Power Macro

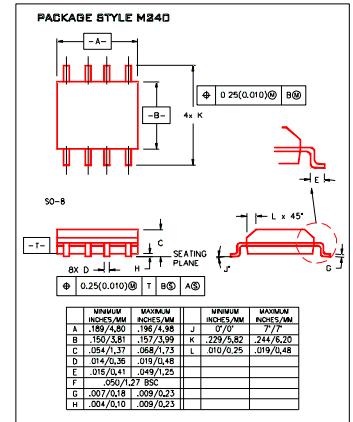

**MRF5812, R1, R2
MRF5812G, R1, R2**

