

AAC242/ 243

Current Mode PWM Contoller

PRELIMINARY DATA

DESCRIPTION

The AAC242 and AAC243 are part of AAI's new family of specialty products for Power Management applications. The AAC242 and AAC243 are high performance integrated circuits designed for Off-line or DC to DC converters using peak current mode control. The AAC24X has a current sense of 250mV in comparison to 1V for AAC14X parts.

In offline AC designs the startup is improved by the low start-up current of the family. The integrated soft-start function adds to the easy of using the AAC24X parts in offline applications.

The AAC242 and AAC243 are identical except for the Under Voltage Lockout. The AAC242 has UVLO_{on} threshold of 16V and off of 10V making it easy to use in offline supplies where startup requirements for energy storage is necessary. For applications using lower supply voltages the AAC243 has UVLO_{on} of 8.4V and UVLO_{off} of 7.6V.

The AAC24X family is offered in DIP and SMD packages. The packages are industry standards and are ROHS compliant. Extended temperature is standard with the AAC24X family.

The greater than 1A output driver is ideal for driving MOSFETs and low power IGBTs. Rise and fall times are typically less than 30ns with a 1000pF load. The improvements in switching speed can provide improvements in efficiency, higher operating frequency and over current protection.

The AAC24X family has a minimum pulse width of 0.4% allowing operation at very low power without pulse skipping or erratic operation. The narrower pulse width capabilities enhances operation at higher frequencies and voltages.



FEATURES

- Low Start-up current
- Pulse by pulse current limiting
- On board voltage reference
- Under Voltage Lockout with hysteresis
- Simple oscillator circuit
- Over Voltage protection zener
- High current output driver
- Less than 30ns rise and fall times
- Operation to over 1MHz
- Peak Current Mode control
- Integrated Soft-Start Function (~330 Clock Cycles)
- 100ns leading edge current blanking for reduced filtering
- 250mV current sense

PIN CONFIGURATION: 8-Lead DIP and SOIC8

View of the AAC24X shown from the top.

COMP	1	8	VREF
VFB	AAC242		VCC
ISENSE	AAC243		OUT
Rt/Ct	4	5	GND

BLOCK DIAGRAM

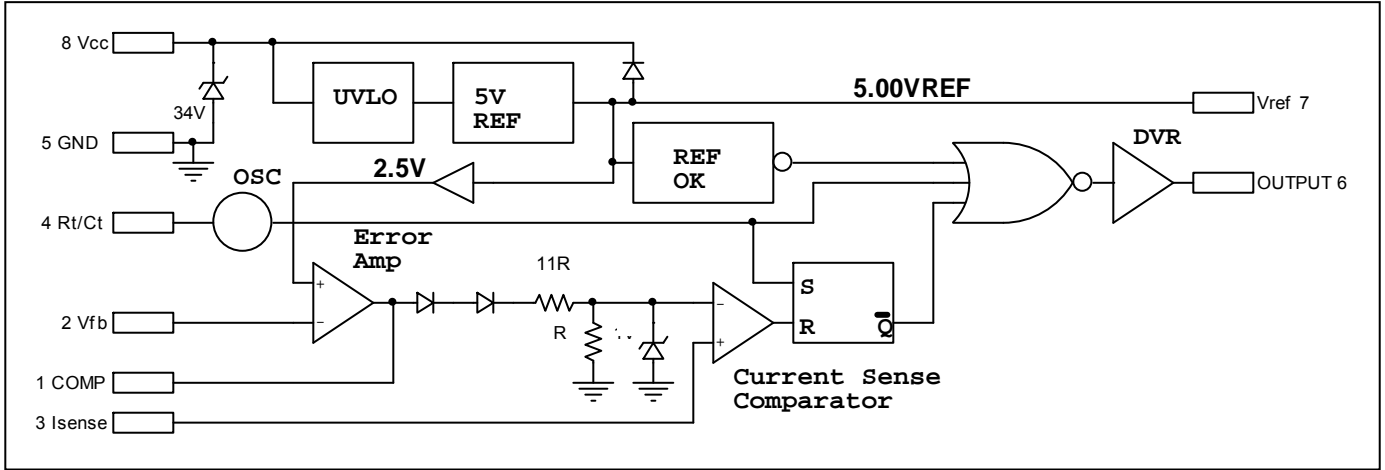

Open Loop Test Circuit

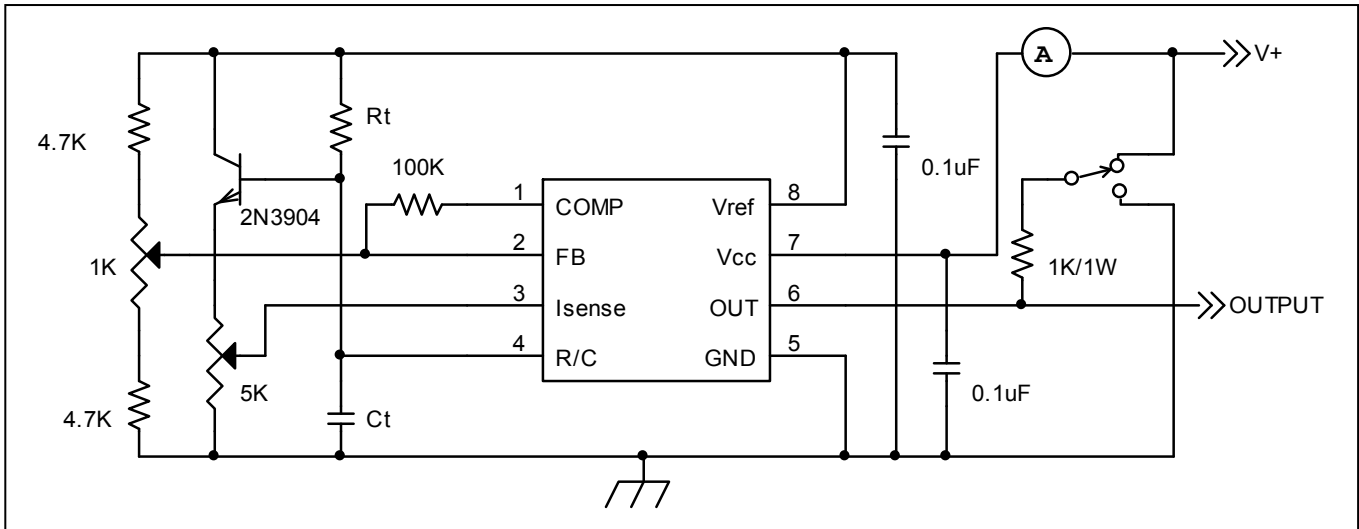

MAXIMUM RATINGS

PARAMETER	PARAMETERS		UNITS	CONDITIONS
	MIN.	MAX.		
Supply Voltage (V _{CC} – Ground)	0	30	V	Low impedance source
V _{fb} and I _{sense} Amp Inputs	-0.3	5.5	V	
Output Current		±1	A	
Power Dissipation		1200	mW	DIP
		1000	mW	SOIC8
Operating Junction Temperature		150	°C	
Operating Ambient Temperature	-40	105	°C	Extended industrial temp. rated devices
Operating Ambient Temperature	-40	125	°C	Automotive temp. rated devices
Storage Temperature Range	-65	150	°C	
Lead Temperature (10 Second)		300	°C	Soldering

ELECTRICAL CHARACTERISTICSUnless otherwise stated, $T=25^{\circ}\text{C}$, $V_{\text{CC}}=15\text{V}$, $R_{\text{T}} = 10\text{K}\Omega$, $C_{\text{T}} = 3300\text{pF}$.

PARAMETER	PARAMETERS			UNITS	CONDITIONS
	MIN.	TYP.	MAX.		
REFERENCE SECTION					
Output Voltage	4.95	5.00	5.05	V	
Line Regulation		6	15	mV	$12\text{V} < V_{\text{CC}} < 25\text{V}$
Load Regulation		3	25	mV	
Temperature Stability		0.2		mV/ $^{\circ}\text{C}$	0°C to 130°C
Total Output Variation	4.9		5.1	V	Line, Load, and Temperature
Long Term Stability		5		mV	$T_{\text{a}}=125^{\circ}\text{C}$ for 1000 hours
Output Short Circuit Current	-30	-50	-60	mA	
OSCILLATOR SECTION					
Frequency Initial Accuracy	47	52	57	KHz	$T_{\text{a}}=25^{\circ}\text{C}$
Frequency Change with Voltage		0.2	1	%	$12 < V_{\text{CC}} < 25\text{V}$
Frequency Change with Temp.		1		%	$T_{\text{low}} < T_{\text{a}} < T_{\text{high}}$
Oscillator Voltage Swing		1.65		V_{pp}	
ERROR AMPLIFIER SECTION					
Voltage Feedback Input	2.45	2.5	2.55	V	$V_{\text{out}}=2.5\text{V}$
Input Bias Current			-1	μA	
Open Loop Voltage Gain		90		dB	
Unity Gain Bandwidth		10		MHz	$T_{\text{j}}=25^{\circ}\text{C}$
Power Supply Rejection Ratio		70		dB	$12\text{V} < V_{\text{CC}} < 25\text{V}$
Output Current Sink		12		mA	
Output Current Source		-1		mA	
Output Voltage Swing High		6		V	
Output Voltage Swing Low		0.8		V	
PULSE WIDTH MODULATION SECTION					
Maximum Duty Cycle		97		%	
Minimum Duty Cycle		0.4		%	Before drop out
CURRENT SENSE SECTION					
Voltage Gain	11.4	12.0	12.6	V	
Maximum Input Signal	242	250	258	mV	
Power Supply Rejection Ratio		70		dB	
Input Bias Current		-10		μA	
Time Delay to Output		300		nS	

PARAMETER	PARAMETERS			UNITS	CONDITIONS
	MIN.	TYP.	MAX.		
OUTPUT SECTION					
Voltage Out Low			0.4	V	Isink = 20mA
Voltage Out Low			2.2	V	Isink = 200mA
Voltage Out High	13.5	14		V	Isink = 20mA
Voltage Out High	12.5	13.5		V	Isink = 200mA
Voltage Out UVLO			1.1	V	Vcc=6V, Isink = 1mA
Voltage Output Rise Time		30	50	ns	CL=1000pF
Voltage Output Fall Time		30	50	ns	CL=1000pF
Current Output Source Peak		1.2		A	
Current Output Sink Peak		0.7		A	
UNDER-VOLTAGE LOCKOUT SECTION					
Voltage Start Threshold (142)	15	16	17	V	
Voltage Start Threshold (143)	7.8	8.4	9	V	
Voltage Turnoff Threshold (142)	9	10	11	V	
Voltage Turnoff Threshold (143)	7	7.6	8.2	V	
Zener Clamp Voltage	30	34		V	I _{cc} ≤ 25mA
TOTAL DEVICE SECTION					
Start-up Supply Current		0.4	0.6	mA	
Operating Supply Current			11	mA	

The improved switching performance increases the high peak current associated with internal and external capacitances and will require careful grounding and PCB trace routing. Bypass and timing capacitors should be of high quality and located carefully with short traces. The reference capacitor must be located very close to the IC with minimum trace lengths. A single point ground should be located at pin 5 ground. The use of a good ground plane is recommended. Under certain conditions of high peak currents it may be advisable to isolate the Vref pin from the bypass capacitor with a resistor to prevent interaction of the high current with the internal oscillator operation.

Charge and discharge times are given by the following formulas:

$$T_C = 0.55R_t C_t$$

$$T_D = R_t C_t \ln[(0.0063R_t - 2.7)/(0.0063R_t - 4)]$$

$$\text{Frequency} = (T_C + T_D)^{-1}$$

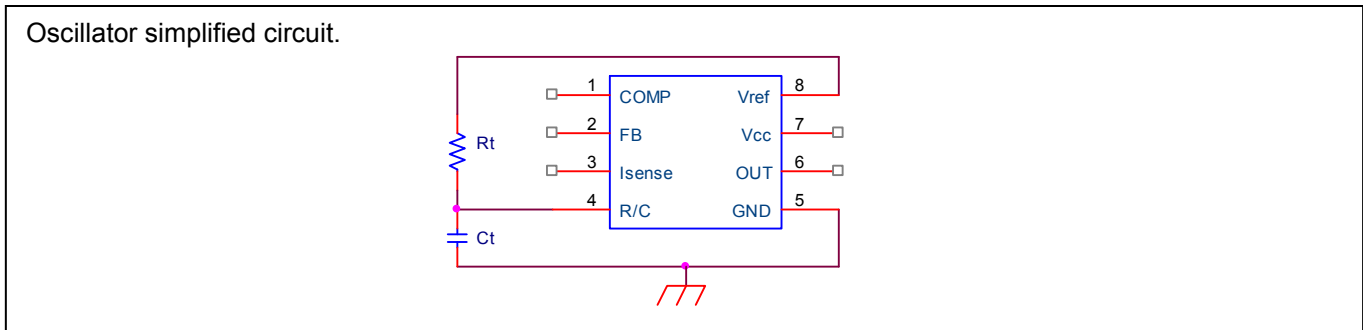

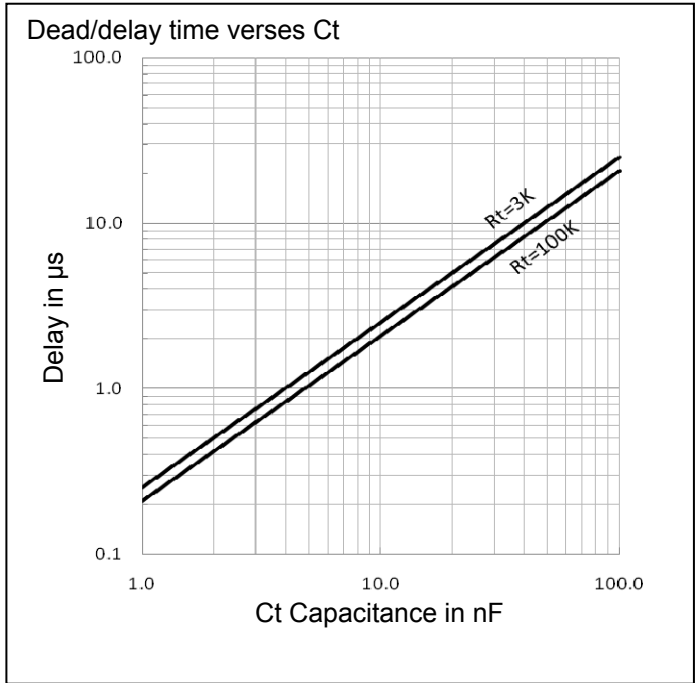
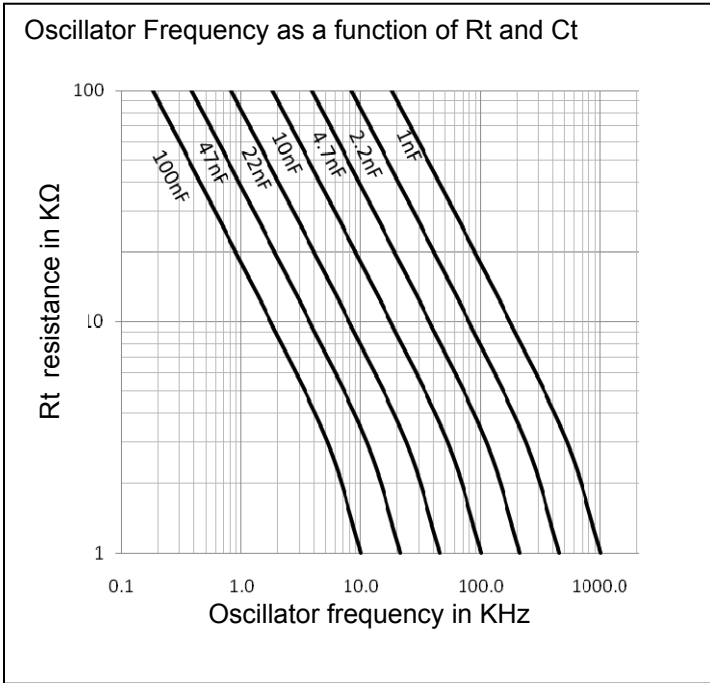

Peak current is set by the internal comparator with a fixed limit of 0.250V. Raising the current sense pin (3) to 0.250V or higher will cause a termination of the output pulse regardless of the error amplifier output. The peak current is normally determined when the current sense pin exceeds the error amplifier conditioned output. Peak current is determined by the formula:

$$I_{SENSE(PK)} = 0.250V/R_s$$

In some cases where leading edge switching transients exceed the 100ns blanking, a small RC filter will be required.

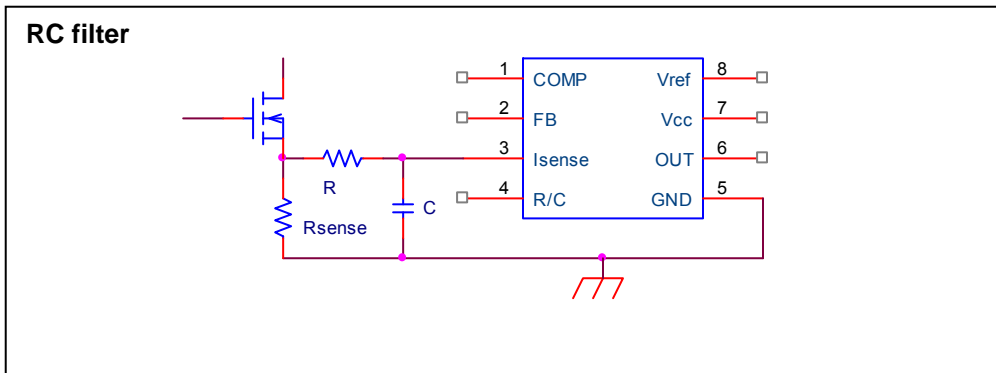

In cases where duty cycle exceeds 50% slope compensation is required. This can be implemented by adding a buffer transistor to the oscillator circuit and using a resistive summing circuit to provide the ramp necessary for slope compensation.

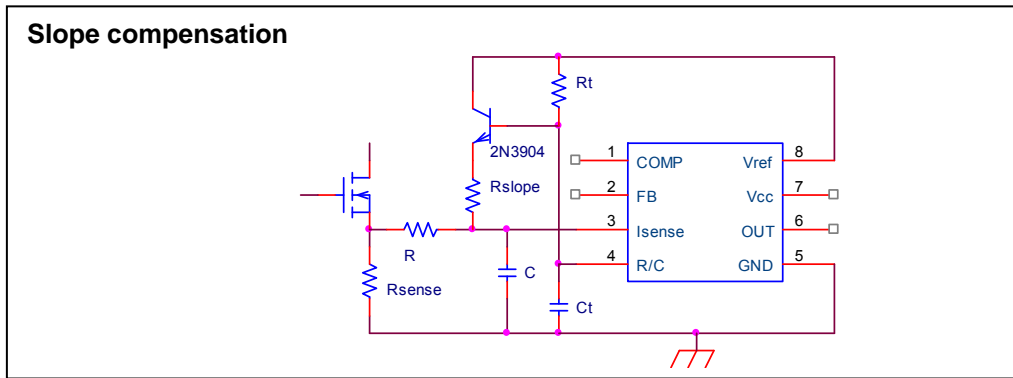

Shut down circuits depend on the desired function. A transistor can be used to allow control on and off of the PWM or an SCR can be used to latch off the PWM.

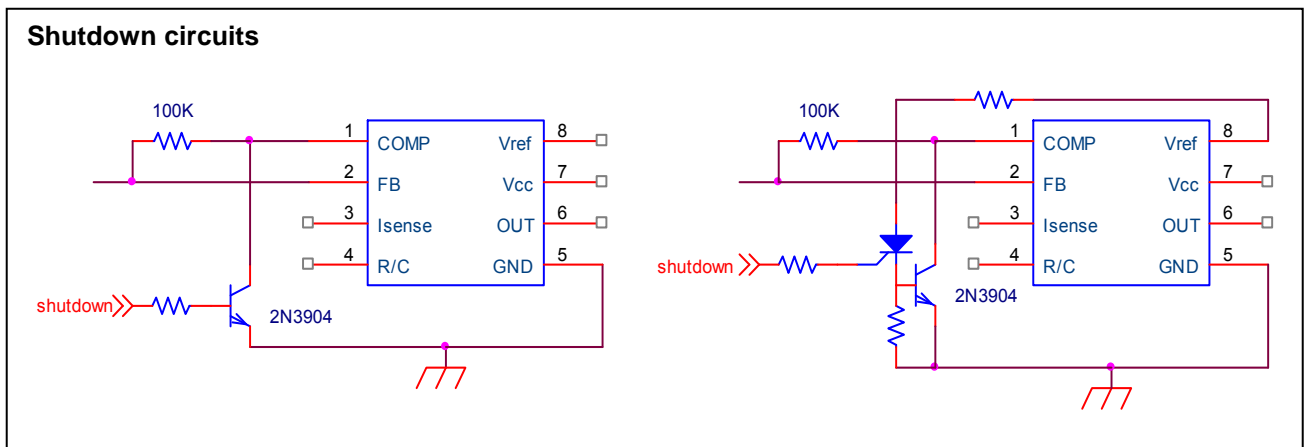

Ordering Information

Ordering PN(1)	Subgroup	Description	Temp. Range	Package	Packing Type	Packing Qty
AAC242E-D8A-G-LF	Controller	Current Mode, Offline Thresholds	Ext. Industrial	8-Pin DIP	Tube	50
AAC242A-D8A-G-LF	Controller	Current Mode, Offline Thresholds	Automotive	8-Pin DIP	Tube	50
AAC242E-S8A-G-LF	Controller	Current Mode, Offline Thresholds	Ext. Industrial	8-Pin SOIC	Tube	98
AAC242E-S8A-G-LF-TR	Controller	Current Mode, Offline Thresholds	Ext. Industrial	8-Pin SOIC	13" T&R (2)	2500
AAC242A-S8A-G-LF	Controller	Current Mode, Offline Thresholds	Automotive	8-Pin SOIC	Tube	98
AAC242A-S8A-G-LF-TR	Controller	Current Mode, Offline Thresholds	Automotive	8-Pin SOIC	13" T&R (2)	2500
AAC242E-F8A-G-LF-W	Controller	Current Mode, Offline Thresholds	Ext. Industrial	3mmx3mm 8-Pin DFN	Waffle Pack	TBD
AC242E-F8A-G-LF-TR	Controller	Current Mode, Offline Thresholds	Ext. Industrial	3mmx3mm 8-Pin DFN	T&R (2)	TBD
AAC242A-F8A-G-LF-W	Controller	Current Mode, Offline Thresholds	Automotive	3mmx3mm 8-Pin DFN	Waffle Pack	TBD
AC242A-F8A-G-LF-TR	Controller	Current Mode, Offline Thresholds	Automotive	3mmx3mm 8-Pin DFN	T&R (2)	TBD
AAC243E-D8A-G-LF	Controller	Current Mode, Battery Level Thresholds	Ext. Industrial	8-Pin DIP	Tube	50
AAC243A-D8A-G-LF	Controller	Current Mode, Battery Level Thresholds	Automotive	8-Pin DIP	Tube	50
AAC243E-S8A-G-LF	Controller	Current Mode, Battery Level Thresholds	Ext. Industrial	8-Pin SOIC	Tube	98
AAC243E-S8A-G-LF-TR	Controller	Current Mode, Battery Level Thresholds	Ext. Industrial	8-Pin SOIC	13" T&R (2)	2500
AAC243A-S8A-G-LF	Controller	Current Mode, Battery Level Thresholds	Automotive	8-Pin SOIC	Tube	98
AAC243A-S8A-G-LF-TR	Controller	Current Mode, Battery Level Thresholds	Automotive	8-Pin SOIC	13" T&R (2)	2500
AC243E-F8A-G-LF-W	Controller	Current Mode, Battery Level Thresholds	Ext. Industrial	3mmx3mm 8-Pin DFN	Waffle Pack	TBD
AAC243E-F8A-G-LF-TR	Controller	Current Mode, Battery Level Thresholds	Ext. Industrial	3mmx3mm 8-Pin DFN	T&R (2)	TBD
AC243A-F8A-G-LF-W	Controller	Current Mode, Battery Level Thresholds	Automotive	3mmx3mm 8-Pin DFN	Waffle Pack	TBD
AAC243A-F8A-G-LF-TR	Controller	Current Mode, Battery Level Thresholds	Automotive	3mmx3mm 8-Pin DFN	T&R (2)	TBD

(1) Only RoHS/Lead-Free Packaging is normally offered.

(2) T&R - Tape and Reel

Package Dimensions and Marking

The AAC242 and AAC243 are available in a plastic 8-pin DIP or SOIC package. Refer to the latest version of specification AAPS001 (ASIC Advantage's "Package Numbering, Marking, and Outline Standard", available at www.asicadvantage.com) for specific information concerning the package dimensions and package marking.

The following is a brief overview of certain terms and conditions of sale of product. For a full and complete copy of all the General Terms and Conditions of Sale, visit our webpage <http://www.asicadvantage.com/terms.htm>.

LIMITED WARRANTY

The product is warranted that it will conform to the applicable specifications and be free of defects for one year. Buyer is responsible for selection of, use of and results obtained from use of the product. Buyer indemnifies and holds ASIC Advantage, Inc. harmless for claims arising out of the application of ASIC Advantage, Inc.'s products to Buyer's designs. Applications described herein or in any catalogs, advertisements or other documents are for illustrative purposes only.

CRITICAL APPLICATIONS

Products are not authorized for use in critical applications including aerospace and life support applications. Use of products in these applications is fully at the risk of the Buyer. Critical applications include any system or device whose failure to perform can result in significant injury to the user.

LETHAL VOLTAGES

Lethal voltages could be present in the applications. Please comply with all applicable safety regulations.

INTELLECTUAL PROPERTY RIGHTS AND PROPRIETARY DATA

ASIC Advantage, Inc. retains all intellectual property rights in the products. Sale of products does not confer on Buyer any license to the intellectual property. ASIC Advantage, Inc. reserves the right to make changes without notice to the products at any time. Buyer agrees not to use or disclose ASIC Advantage Inc.'s proprietary information without written consent.

TRADEMARKS AND PATENTS

- IN-PLUG® is a registered trademark of ASIC Advantage, Inc.
- AAI's modified snubber network is patented under the US Patent # 6,233,165

PROTECTION FOR CUSTOM SOLUTIONS

When AAI accepts to design and manufacture products to Buyer's designs or specifications, buyer has certain obligations to provide defense in a suit or proceeding claiming infringement of a patent, copyright or trademark or for misappropriation of use of any trade secrets or for unfair competition.

COMPLIANCE WITH LAWS

Buyer agrees that at all times it will comply with all applicable federal, state, municipal, and local laws, orders and regulations. Buyer agrees to comply with all applicable restrictions on exports and re-exports including obtaining any required U.S. Government license, authorization, or approval. Buyer shall pay any duties, levies, taxes, brokerage fees, or customs fees imposed on the products.

TITLE AND DELIVERY

All shipments of goods shall be delivered ExWorks, Sunnyvale, CA, U.S.A. Title in the goods shall not pass to Buyer until ASIC Advantage, Inc. has received in full all amounts owed by Buyer.

LATEST DATASHEET UPDATES

For the latest datasheet updates, visit our web page: <http://www.asicadvantage.com>.

WORLDWIDE REPRESENTATIVES

To access AAI's list of worldwide representatives, visit our web page <http://www.asicadvantage.com>.

COPYRIGHTS

Copyrights and all other proprietary rights in the Content rests with ASIC Advantage Inc. (AAI) or its licensors. All rights in the Content not expressly granted herein are reserved. Except as otherwise provided, the Content published on this document may be reproduced or distributed in unmodified form for personal non-commercial use only. Any other use of the Content, including without limitation distribution, reproduction, modification, display or transmission without the prior written consent of AAI is strictly prohibited. All copyright and other proprietary notices shall be retained on all reproductions.

ASIC Advantage INC.

1290-B Reamwood Ave, Sunnyvale California 94089, USA
Tel: (1) 408-541-8686 Fax: (1) 408-541-8675
Websites: <http://www.asicadvantage.com>