

DESCRIPTION

This line of 'MELF' high power PIN diodes are hermetically sealed surface mount packaged devices with full face bonded chips for low inductance construction. The MELF ceramic package has square end terminations which are ideal for surface mount and pick and place operations. The PIN diode chips are coated with a special hard glass passivation which is required for high power applications and to enhance the reliability resulting in MTBFs of greater than one million hours.

RoHS compliant versions of these products meet RoHS requirements per EU Directive 2002/95/EC. The standard terminal finish is gold unless otherwise specified. Consult the factory if you have special requirements.

KEY FEATURES

- Non-Magnetic¹ Versions Ideal for MRI Applications
- Very Low Inductance, Full Face Bonding
- Hi-Rel Hermetic Design
- Surface Mount Devices Available in Tape and Reel
- RoHS Compliant² Versions Available

APPLICATIONS

The MELF diodes are used as switching, attenuating and phase shifting elements from HF through 2 GHz and have breakdown voltage ratings up to 500 volts. 'Non-magnetic'¹ Cer-Met. (MELFs) are also used as switching elements in MRI (magnetic resonance imaging). Conventional Magnetic MELF packages are used in Cellular, Beam Steering units (telephone via satellites) surface mount applications, and Filter Switch banks for Frequency Hopping Radios.

**ABSOLUTE MAXIMUM RATINGS AT 25° C
(UNLESS OTHERWISE SPECIFIED)**

Rating	Symbol	Value	Unit
Maximum Leakage Current @80% of Minimum Rated V_B	I_R	500	nA
Forward Current (1us Pulse)	I_F	1	A
Storage Temperature	T_{STG}	-55 to +150	°C
Operating Temperature	T_{OP}	-55 to +150	°C

APPLICATIONS/BENEFITS

- Designed for Low Loss – Low Distortion Applications
- Switch – Filter Bank
- T/R Control
- Attenuators
- MRI Switching



IMPORTANT: For the most current data, consult our website: www.MICROSEMI.com
 Specifications are subject to change, consult factory for the latest information.



These devices are ESD sensitive and must be handled using ESD precautions.

¹ 'Non Magnetic' refers to any products that are designed with low and ultra low magnetic materials for use in MRI systems

² RoHS versions are supplied with a matte tin finish.

ELECTRICAL PARAMETERS @ 25°C (unless otherwise specified)

Model Number	V _b (V) I _R =10μA	C _T (pF) ¹ @50V	R _s (Ω) ² @100 mA	R _s (Ω) ² @200 mA	T _L (μS)	θ _P (°C/W) THERMAL RESISTANCE (Max)
	(Min)	(Max)	(Max)	(Typ)	(Typ)	(Max)
SM0502 – M1	500	0.5	0.7	0.55	1.0	35
SM0504 – M1	500	0.6	0.6	0.45	1.5	20
SM0508 – M1	500	0.9	0.4	0.25	2.0	15
SM0509 – M1	500	1.2	0.35	0.2	2.5	15
SM0511 – M1	500	1.25	0.3	0.15	3.0	15
SM0512 – M1	500	1.5	0.25	0.12	3.5	15
SM1002 – M1	50	1.2	0.75@50mA	0.2	4.0	15
SM1003 – M1	35	1.2 @20V	0.5@10mA	0.1	0.6	25

Notes:

- 1- Capacitance (C_T) is measured at F = 1 MHz
- 2- Series Resistance (R_s) is measured at F = 100 MHz

RoHS and MRI Models

Base Model	RoHS Compliant PN	Non-Mag. / RoHS PN
SM0502 – M1	SMX0502 – M1	SMX0502MR – M1
SM0504 – M1	SMX0504 – M1	SMX0504MR – M1
SM0508 – M1	SMX0508 – M1	SMX0508MR – M1
SM0509 – M1	SMX0509 – M1	SMX0509MR – M1
SM0511 – M1	SMX0511 – M1	SMX0511MR – M1
SM0512 – M1	SMX0512 – M1	SMX0512MR – M1
SM1002 – M1	SMX1002 – M1	SMX1002MR – M1
SM1003 – M1	SMX1003 – M1	SMX1003MR – M1

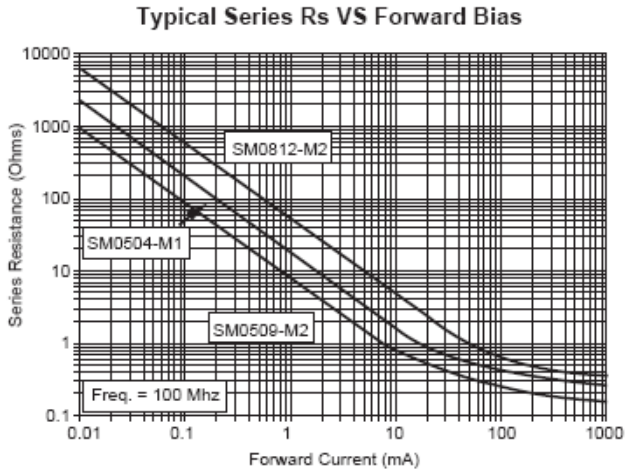
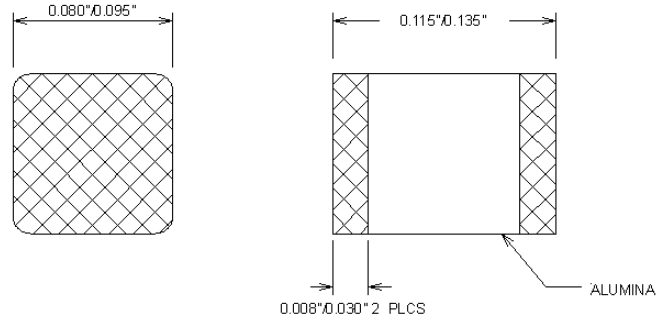
TYPICAL RS CURVES

PACKAGE STYLE 'M1'

SOLDER PAD LAYOUT
