

DESCRIPTION

Hybrid microwave integrated circuit applications utilizing stripline or microstrip substrates generally require that the active components be of appropriate size and integrity so that the physical constraints imposed by handling and bonding and electrical performance demands can be met. The GC4800 series planar PIN diodes are offered to meet the above MIC demands as well as conform to established industry norms on minimum expected performance and geometric format and convention.

The device structure consists of two plated co-planar leads (commonly referred to as “beams”) extending from the “P” and “N” type contacts selectively located on the semiconductor substrate. Our application notes offer an explanation of the device’s operational characteristics and how they may be useful in specific circuit designs.

Thermal oxide junction passivation is incorporated into the structural design for electrical permanence (low conductive leakage, stable capacitance and reverse breakdown voltage).

This series of devices meets RoHS requirements per EU Directive 2002/95/EC.

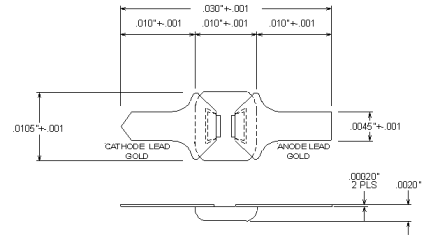

KEY FEATURES

- Low Series Resistance
- Low Capacitance
- Fast Switching
- Electrically Stable Performance
- Sound Device Construction
- Performance through 18 GHz
- RoHS Compliant

APPLICATIONS

The GC4800 series beam lead PIN diodes, with their characteristically low series resistance, low junction capacitance and low parasitic reactance, are ideally suited for low power series or shunt switching, limiting, phase shifting, attenuating and demodulating applications in stripline or microstrip format through Ku band. The GC4801, with its low series resistance and junction capacitance, would be a better choice for applications requiring high isolation in a series mode switch. Please refer to *MicroNote* 713 for device and circuit design information as well as helpful tips on handling and bonding.

APPLICATIONS/BENEFITS

- High Speed Switching
- Broadband Performance
- Suitable for Applications through 26 Ghz

ABSOLUTE MAXIMUM RATINGS @ 25° C (Unless Otherwise Specified)

Rating	Symbol	Value	Unit
Maximum Leakage Current @80% of minimum Rated V_B	I_R	0.5	uA
Operating Temperature	T_{OP}	-55 to +150	°C
Storage Temperature	T_{STG}	-65 to +150	°C

 These devices are ESD sensitive and must be handled using ESD precautions. For the most current data, consult our website: www.MICROSEMI.com Specifications are subject to change, consult factory for the latest information.

¹ The GC4800 Series of products are supplied with a RoHS complaint Gold finish.

ELECTRICAL PARAMETERS @ 25°C (Unless Otherwise Specified)

Model Number	V_b (V) $I_R=10\mu A$ (Min)	C_T (pF) @10V (Typ / Max)	C_T (pF) @50V (Typ / Max)	R_s (Ω) @20mA (Typ / Max)	R_s (Ω) @50mA (Typ / Max)	T_L (nS) (Typ)	T_s (nS) (Typ)	V_F (V) $I_F=50mA$ (Typ)
GC4800A – 14	80	0.016 / 0.020	--	4.5 / 6.5		150	30	1.0
GC4801 – 14	100		0.018 / 0.020		3.5 / 4.0	150	30	1.0
GC4802 – 14	100		0.060 / 0.070		2.2 / 3.0	150	30	1.0
GC4810 - 16	150		0.025 / 0.035		3.0 / 4.0	300	50	1.0

Notes:

1 – R_s and C_T are determined using Loss and Isolation measurements at $F = 2.2$ GHz.

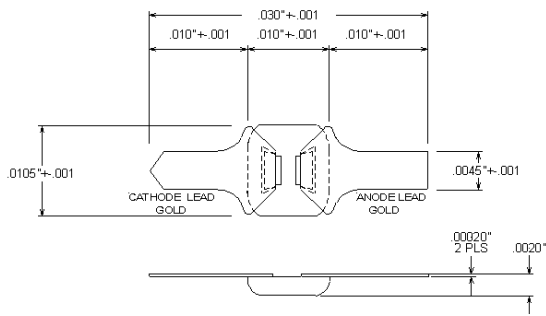
PACKAGE STYLE 14

PACKAGE STYLE 16
