

**DESCRIPTION**

The GC4400 series are high voltage, high power (cathode base) PIN diodes. These high resistivity silicon devices are glass passivated for high stability and reliability and have been proven by thousands of device hours in high reliability systems.

Each device can withstand storage temperatures from -65°C to +200°C and will operate over the range from -55°C to +150°C. All devices meet or exceed military environmental specifications of MIL-PRF-19500.

The GC4400 series will operate typically with +50 mA forward bias. Breakdown voltages are available up to 750 volts. Consult the factory for higher voltage devices.

**APPLICATIONS**

The GC4400 series can be used in RF circuits as an on/off element, as a switch, or as a current controlled resistor in attenuators extending over the frequency range from UHF through Ku band.

Switch applications include high speed switches (ECM systems), TR or lobing switches, channel or antenna selection switches (telecommunications), duplexers (radar) and digital phase shifters (phased arrays).

The GC4400 series can be used in RF circuits as an on/off at moderate RF power levels.

Attenuator type applications include amplitude modulators, AGC attenuators, power levelers and level set attenuators.

**KEY FEATURES**

- Available as packaged devices or as chips for hybrid applications
- High power handling
- Suitable for application to 18Ghz
- Low Loss
- Low Distortion
- RoHS Compliant<sup>1</sup>

<sup>1</sup> Products are supplied with a Gold finish and are suitable for RoHS complaint assembly. Consult factory for details.

**APPLICATIONS/BENEFITS**

- TR Switches
- Antenna Selector Switches
- Duplexers
- Digital Phase Shifters

**ABSOLUTE MAXIMUM RATINGS AT 25° C  
(UNLESS OTHERWISE SPECIFIED)**

Rating	Symbol	Value	Unit	
Leakage Current @80% Minimum Rated V <sub>B</sub>	GC441X GC443X	I <sub>R</sub>	0.5	uA
Leakage Current @80% Minimum Rated V <sub>B</sub>	GC449X	I <sub>R</sub>	1.0	uA
Operating Temperature	T <sub>OP</sub>	-55 to +150	°C	
Storage Temperature	T <sub>STG</sub>	-65 to +200	°C	

**IMPORTANT:** For the most current data, consult MICROSEMI's website: [www.MICROSEMI.com](http://www.MICROSEMI.com)  
Specifications are subject to change, consult the factory for further information.



These devices are ESD sensitive and must be handled using ESD precautions.

**ELECTRICAL CHARACTERISTICS AT 25 °C**

Model Number	V <sub>b</sub> (V) I <sub>R</sub> =10uA  (Min)	C <sub>j</sub> <sup>1</sup> (pF) V <sub>R</sub> = 50V  (Max)	R <sub>s</sub> <sup>2</sup> (Ω) I <sub>F</sub> = 100 mA F=100 MHz (Max)	T <sub>L</sub> (uS) I <sub>R</sub> =6 mA I <sub>F</sub> =10 mA (Typ)	θP <sup>2</sup> (°C/W) THERMAL RESISTANCE (Max)
GC4410	100	0.10	0.6	0.4	40
GC4411	100	0.25	0.5	0.6	25
GC4412	100	0.50	0.4	0.8	20
GC4413 <sup>3</sup>	100	0.75	0.3	1.2	10
GC4430	300	0.10	1.5	0.6	40
GC4431	300	0.25	1.2	1.2	30
GC4432	300	0.50	1.0	1.5	20
GC4433 <sup>3</sup>	300	0.75	0.8	2.0	10
GC4490	750	0.10	1.5	1.0	30
GC4491	750	0.25	1.2	2.0	25
GC4492	750	0.50	1.0	3.0	20
GC4493 <sup>3</sup>	750	0.75	0.8	5.0	10
GC4494	750	1.30	0.35	6.0	7
GC4495	750	2.50	0.30	7.5	5

1. Capacitance is measured at 1 MHz and -50 volts.
2. Resistance is measured using transmission loss techniques using a 30 style package.
3. These devices are not available in all case styles. Please consult the factory for specific package styles offered.

**DEVICE NOTES**

The tabulated specifications above are for package style 00. Diodes are also available in various packaged configurations. Some limitations apply. Consult factory for details.

Each type offers trade offs in series resistance, junction capacitance, carrier lifetime and breakdown voltage; the proper choice of which depends on the end application. Reverse polarity diodes (NIP) and faster speed PIN and NIP diodes are also available. (See data sheets for GC4500, GC4200, and GC4300 series respectively.)

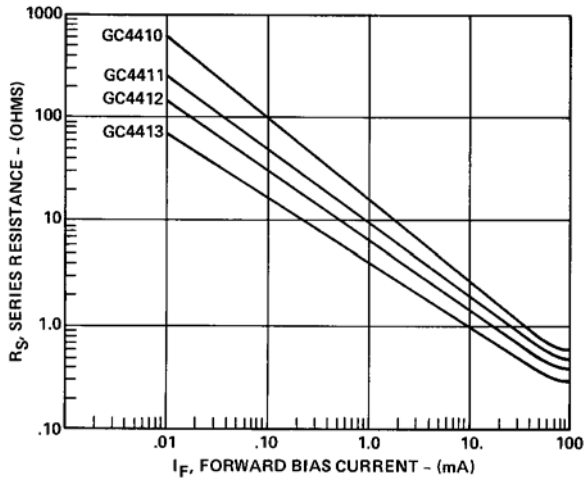
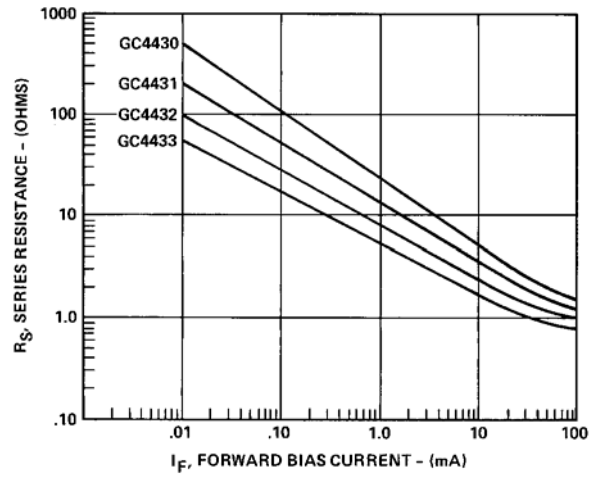
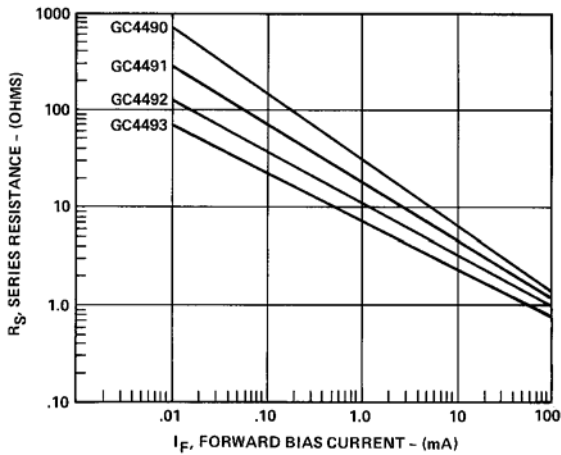
**RS VS IF (GC4410-GC4413)**

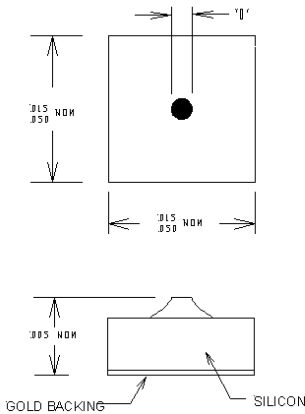
**RS VS IF (GC4430-GC4433)**

**RS VS IF (GC4490-GC4493)**

**PACKAGE STYLE 00**

- NOTES:
1. TOP CONTACT, CHIP SIZE, AND CHIP THICKNESS DEPENDS ON DIODE PARAMETERS. CONSULT FACTORY.
  2. TOP AND BOTTOM CONTACTS GOLD.

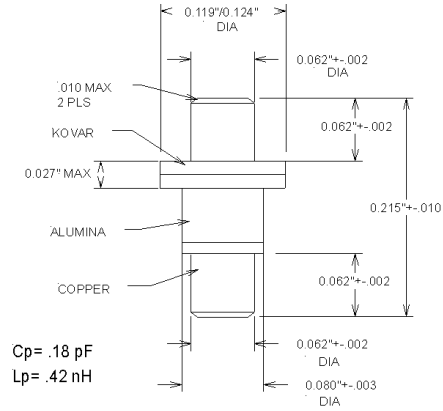
**Notes:**

- Dimensions vary by model number
- Consult factory for details
- Order as GC44xx – 00

**PACKAGE SYLE 30**

**Notes:**

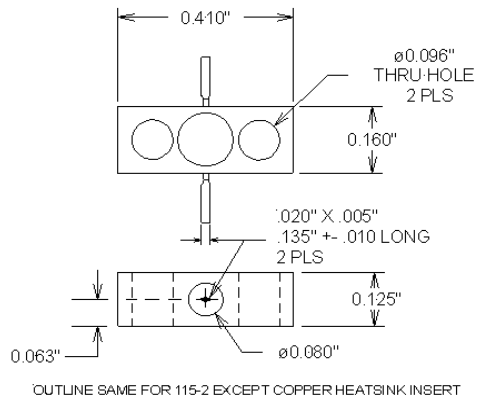
- Order as GC44xx – 30

**PACKAGE STYLE 115**

**Notes:**

- Order as GC44xx – 115

**OTHER PACKAGE STYLES AVAILABLE ON REQUEST  
CONSULT FACTORY**