

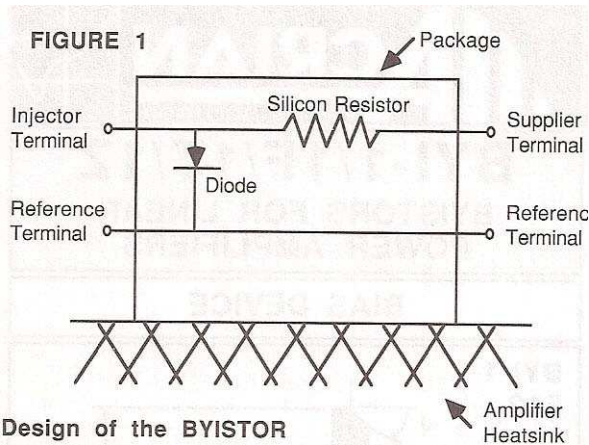

# BYI-1



### Design of the BYISTOR

The key elements of a BYISTOR are:

- A diode fabricated like and RF power transistor ( same material, geometry, and diffusion process) for improved temperature tracking;
- An internal silicon resistor to further improve temperature tracking;
- A package that can be physically attached to the same heatsink used for the RF amplifier transistor ( available in a variety of stud, flange or flangeless packages)

Fig. 1 shows the basic design of a BYISTOR. By providing a constant current to the injector terminal, the diode acts as a voltage source with approximately  $0.3\Omega$  source impedance. The addition of a silicon resistor (approximately  $0.7\Omega$ ) increases the apparent source impedance of the BYISTOR to approximately  $1\Omega$ .

The silicon resistor increases in resistance, and the diode voltage decreases with increasing temperature. As a result, the source impedance of the BYISTOR increases, and the bias voltage decreases with increasing temperature (see Fig 2 & 3). By mounting the package on the same heatsink as the RF transistor, the BYISTOR will thermally track the transistor and compensate for the reduction in  $V_{be}$ . The result is improved D.C. stability of the amplifier and elimination of D.C. thermal runaway of the RF transistor..

### Circuit Applications

To effectively use a BYISTOR, it should be mounted on the same heatsink and as physically close to the RF power transistor as possible. Connect the bias circuit as shown in Fig. 4 for class AB operation. Provide approximately 350 mA from any convenient voltage into the injector terminal. Then, adjust R2 until the desired static collector current is achieved (increasing R2 increases the  $V_{be}$  and increases the static collector current). No further effort is required. The bias circuit using the BYISTOR will now:

- \*Provide the appropriate static collector current;
- \*Provide a low impedance D.C. voltage source
- \*Thermally track the RF transistor and compensate for increasing temperatures, eliminating D.C. thermal runaway problems.

**FIGURE 2**

Characteristic Performance of a BYISTOR

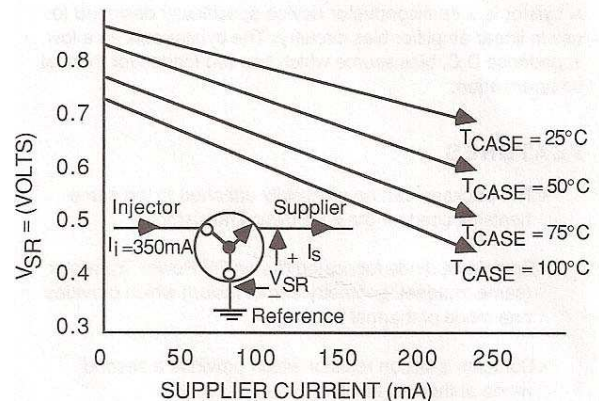

**FIGURE 3**

Equivalent Output Circuit of a BYISTOR as a Function of Temperature

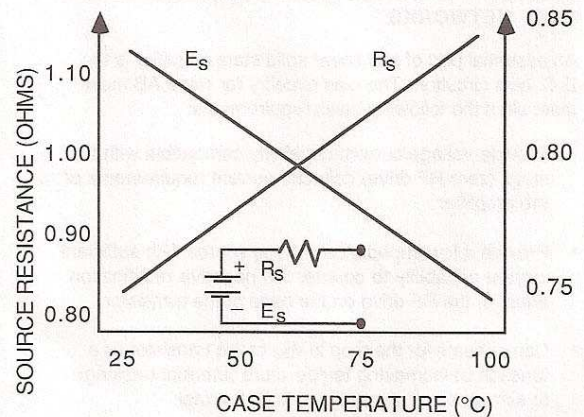

**FIGURE 4**

Class AB BYISTOR Circuit Application

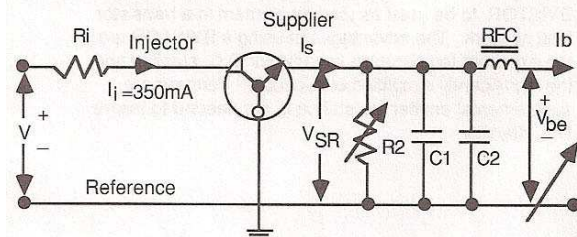

(NOTE: Mount BYISTOR on the same heatsink as close to the RF transistor as possible)