

Ultrasonic retro-reflective sensors

URAM 50P7121

dimension drawing

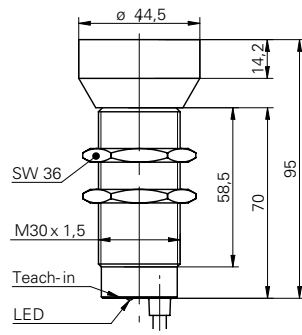

general data

scanning range sd	0 ... 3000 mm
reflector position Sde	600 ... 3000 mm
adjusting range reflector (operating range)	± 4 % Sde
adjusting range reflector (limit range)	± 6 % Sde
repeat accuracy	< 3 mm
alignment aid	target indication flashing
adjustment	Teach-in
temperature drift	< 2 % Sde
synchronization	yes
multiplex version	on request
response time ton	< 160 ms
release time toff	< 160 ms
sonic frequency	120 kHz
output indicator	LED green

electrical data

voltage supply range +Vs	12 ... 30 VDC
current consumption max. (no load)	35 mA
output circuit	PNP break function (NC)
output current	< 200 mA
voltage drop Vd	< 2 VDC
residual ripple	< 10 % Vs
short circuit protection	yes
reverse polarity protection	yes

mechanical data

type	cylindrical threaded
housing material	brass nickel plated
width / diameter	30 mm
height / length	95 mm
connection types	cable, 2 m

ambient conditions

operating temperature	-10 ... +60 °C
protection class	IP 67

photo



connection diagram



- Reflector position set by Teach-in
- no blind spot area for objects > 100 mm