

## Buck chopper MOSFET Power Module

$V_{DSS} = 1000V$   
 $R_{DSon} = 400m\Omega$  typ @  $T_j = 25^\circ C$   
 $I_D = 20A$  @  $T_c = 25^\circ C$

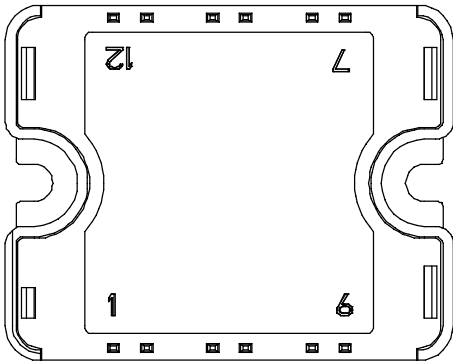
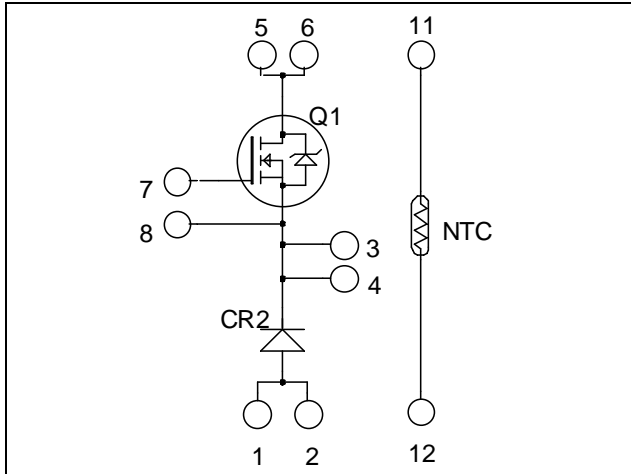

Pins 1/2 ; 3/4 ; 5/6 must be shorted together

### Application

- AC and DC motor control
- Switched Mode Power Supplies

### Features

- Power MOS 8™ MOSFETs
  - Low  $R_{DSon}$
  - Low input and Miller capacitance
  - Low gate charge
  - Avalanche energy rated
  - Very rugged
- Very low stray inductance
- Internal thermistor for temperature monitoring
- High level of integration

### Benefits

- Outstanding performance at high frequency operation
- Direct mounting to heatsink (isolated package)
- Low junction to case thermal resistance
- Solderable terminals both for power and signal for easy PCB mounting
- Low profile
- RoHS Compliant

### Absolute maximum ratings

Symbol	Parameter	Max ratings	Unit
$V_{DSS}$	Drain - Source Breakdown Voltage	1000	V
$I_D$	Continuous Drain Current	$T_c = 25^\circ C$	20
		$T_c = 80^\circ C$	15
$I_{DM}$	Pulsed Drain current	120	
$V_{GS}$	Gate - Source Voltage	$\pm 30$	V
$R_{DSon}$	Drain - Source ON Resistance	480	$m\Omega$
$P_D$	Maximum Power Dissipation	$T_c = 25^\circ C$	357
$I_{AR}$	Avalanche current (repetitive and non repetitive)	16	A

**CAUTION:** These Devices are sensitive to Electrostatic Discharge. Proper Handling Procedures Should Be Followed. See application note APT0502 on [www.microsemi.com](http://www.microsemi.com)

All ratings @  $T_j = 25^\circ\text{C}$  unless otherwise specified

**Electrical Characteristics**

Symbol	Characteristic	Test Conditions		Min	Typ	Max	Unit
$I_{DSS}$	Zero Gate Voltage Drain Current	$V_{DS} = 1000\text{V}$ $V_{GS} = 0\text{V}$	$T_j = 25^\circ\text{C}$			100	$\mu\text{A}$
			$T_j = 125^\circ\text{C}$			500	
$R_{DS(on)}$	Drain – Source on Resistance	$V_{GS} = 10\text{V}, I_D = 16\text{A}$			400	480	$\text{m}\Omega$
$V_{GS(th)}$	Gate Threshold Voltage	$V_{GS} = V_{DS}, I_D = 2.5\text{mA}$		3	4	5	V
$I_{GSS}$	Gate – Source Leakage Current	$V_{GS} = \pm 30\text{V}$				$\pm 100$	$\text{nA}$

**Dynamic Characteristics**

Symbol	Characteristic	Test Conditions		Min	Typ	Max	Unit
$C_{iss}$	Input Capacitance	$V_{GS} = 0\text{V}$			6800		$\text{pF}$
$C_{oss}$	Output Capacitance	$V_{DS} = 25\text{V}$			700		
$C_{rss}$	Reverse Transfer Capacitance	$f = 1\text{MHz}$			92		
$Q_g$	Total gate Charge	$V_{GS} = 10\text{V}$			260		$\text{nC}$
$Q_{gs}$	Gate – Source Charge	$V_{Bus} = 500\text{V}$			46		
$Q_{gd}$	Gate – Drain Charge	$I_D = 16\text{A}$			125		
$T_{d(on)}$	Turn-on Delay Time	<b>Resistive switching @ <math>25^\circ\text{C}</math></b>			39		$\text{ns}$
$T_r$	Rise Time	$V_{GS} = 15\text{V}$ $V_{Bus} = 667\text{V}$			35		
$T_{d(off)}$	Turn-off Delay Time	$I_D = 16\text{A}$			130		
$T_f$	Fall Time	$R_G = 2.2\Omega$			33		

**Chopper diode ratings and characteristics**

Symbol	Characteristic	Test Conditions		Min	Typ	Max	Unit
$V_{RRM}$	Maximum Peak Repetitive Reverse Voltage			1200			V
$I_{RM}$	Maximum Reverse Leakage Current	$V_R = 1200\text{V}$	$T_j = 25^\circ\text{C}$			100	$\mu\text{A}$
			$T_j = 125^\circ\text{C}$			500	
$I_F$	DC Forward Current	$T_c = 80^\circ\text{C}$			30		A
$V_F$	Diode Forward Voltage	$I_F = 30\text{A}$			2.6	3.1	V
		$I_F = 60\text{A}$			3.2		
		$I_F = 30\text{A}$	$T_j = 125^\circ\text{C}$		1.8		
$t_{rr}$	Reverse Recovery Time	$I_F = 30\text{A}$ $V_R = 800\text{V}$ $di/dt = 200\text{A}/\mu\text{s}$	$T_j = 25^\circ\text{C}$		300		$\text{ns}$
			$T_j = 125^\circ\text{C}$		380		
$Q_{rr}$	Reverse Recovery Charge				360		$\text{nC}$
					1700		

**Thermal and package characteristics**

Symbol	Characteristic			Min	Typ	Max	Unit
$R_{thJC}$	Junction to Case Thermal Resistance	Transistor				0.35	$^\circ\text{C}/\text{W}$
		Diode				1.2	
$V_{ISOL}$	RMS Isolation Voltage, any terminal to case $t = 1\text{ min}$ , $I_{isol} < 1\text{mA}$ , 50/60Hz			2500			V
$T_j$	Operating junction temperature range			-40		150	$^\circ\text{C}$
$T_{STG}$	Storage Temperature Range			-40		125	
$T_C$	Operating Case Temperature			-40		100	
Torque	Mounting torque	To heatsink	M4	2.5		4.7	
Wt	Package Weight					80	g

**Temperature sensor NTC** (see application note APT0406 on [www.microsemi.com](http://www.microsemi.com) for more information).

**Symbol Characteristic**

		<i>Min</i>	<i>Typ</i>	<i>Max</i>	<i>Unit</i>
R <sub>25</sub>	Resistance @ 25°C		50		kΩ
B <sub>25/85</sub>	T <sub>25</sub> = 298.15 K		3952		K

$$R_T = \frac{R_{25}}{\exp \left[ B_{25/85} \left( \frac{1}{T_{25}} - \frac{1}{T} \right) \right]}$$

T: Thermistor temperature  
 R<sub>T</sub>: Thermistor value at T

### SP1 Package outline (dimensions in mm)

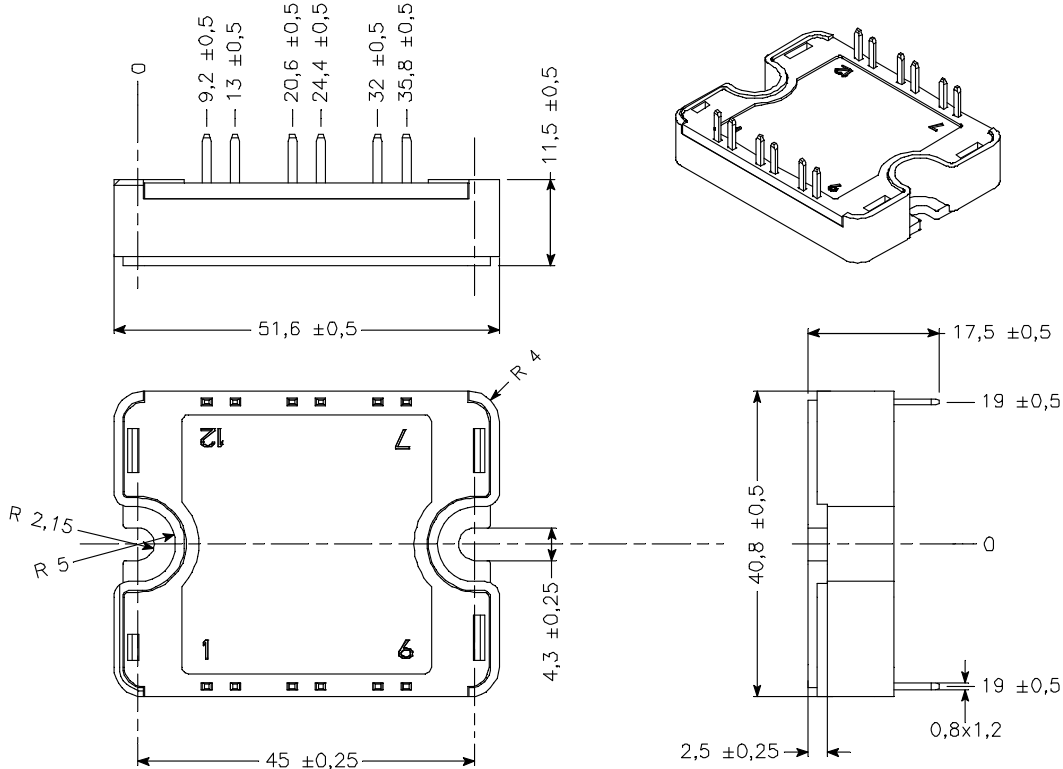

See application note 1904 - Mounting Instructions for SP1 Power Modules on [www.microsemi.com](http://www.microsemi.com)

### Typical Mosfet Performance Curve

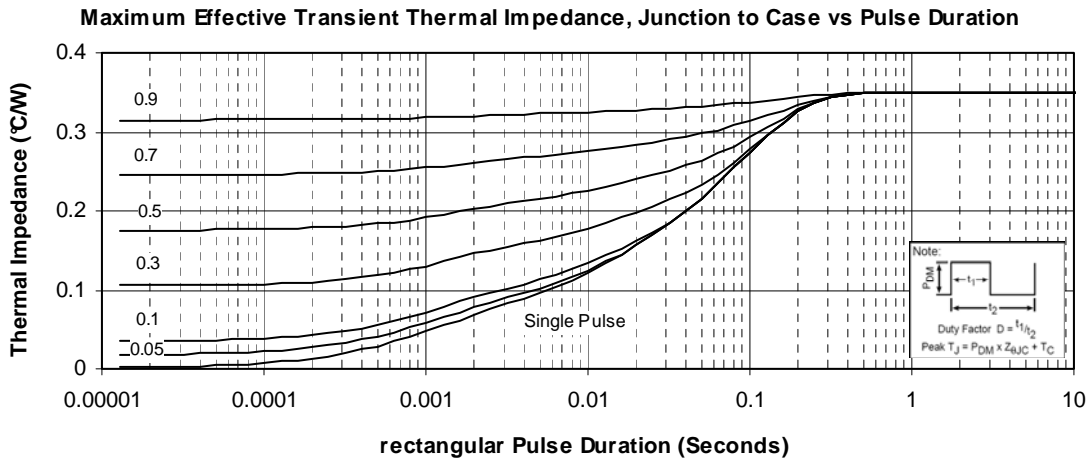

Low Voltage Output Characteristics

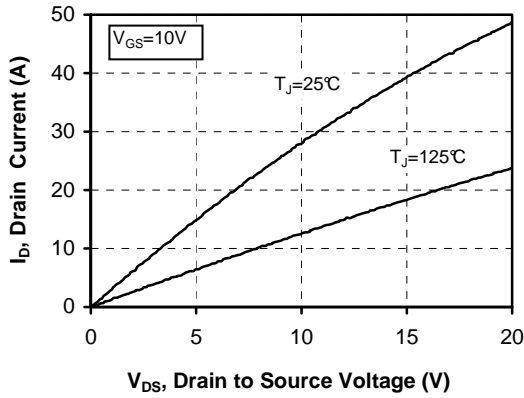

Low Voltage Output Characteristics

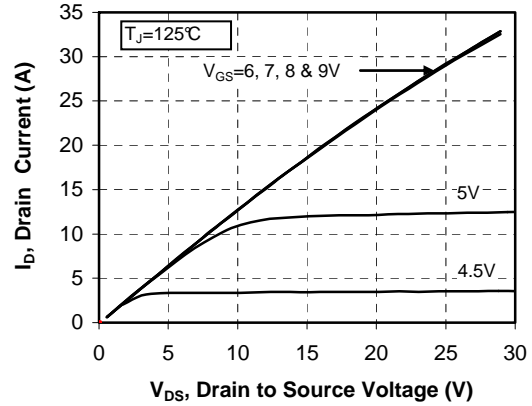

Normalized  $R_{DS(on)}$  vs. Temperature

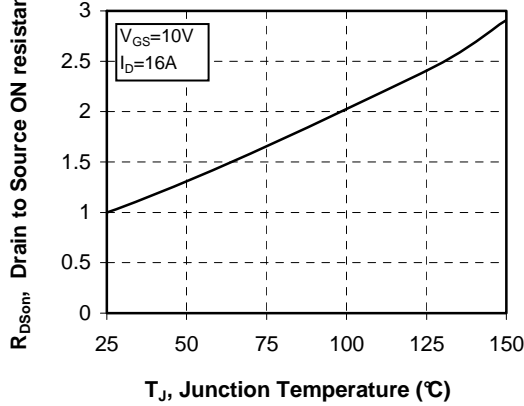

Transfer Characteristics

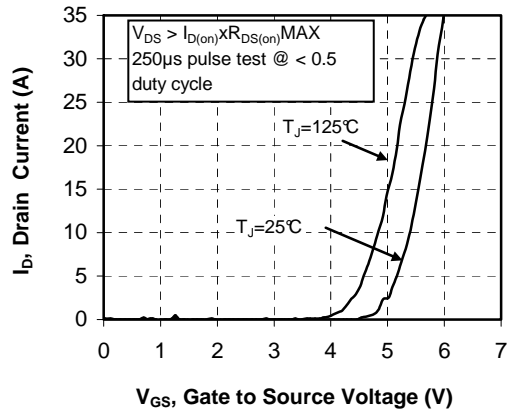

Gate Charge vs Gate to Source

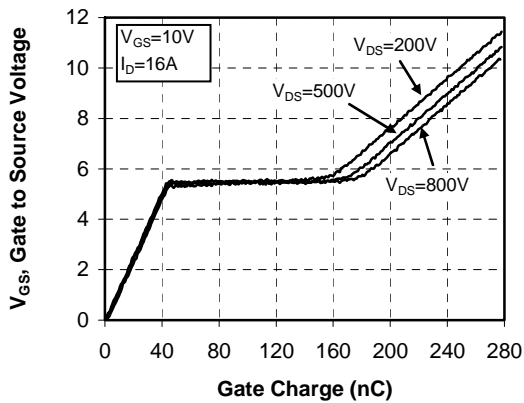

Capacitance vs Drain to Source Voltage

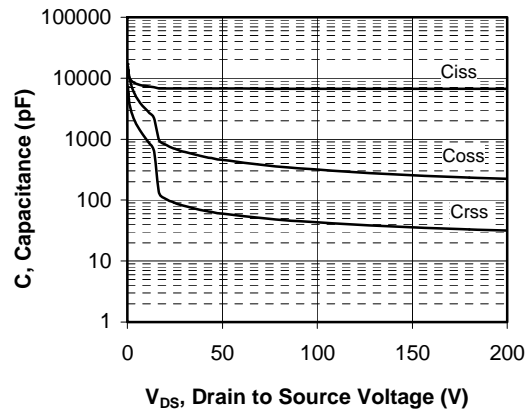

## Typical Diode Performance Curve

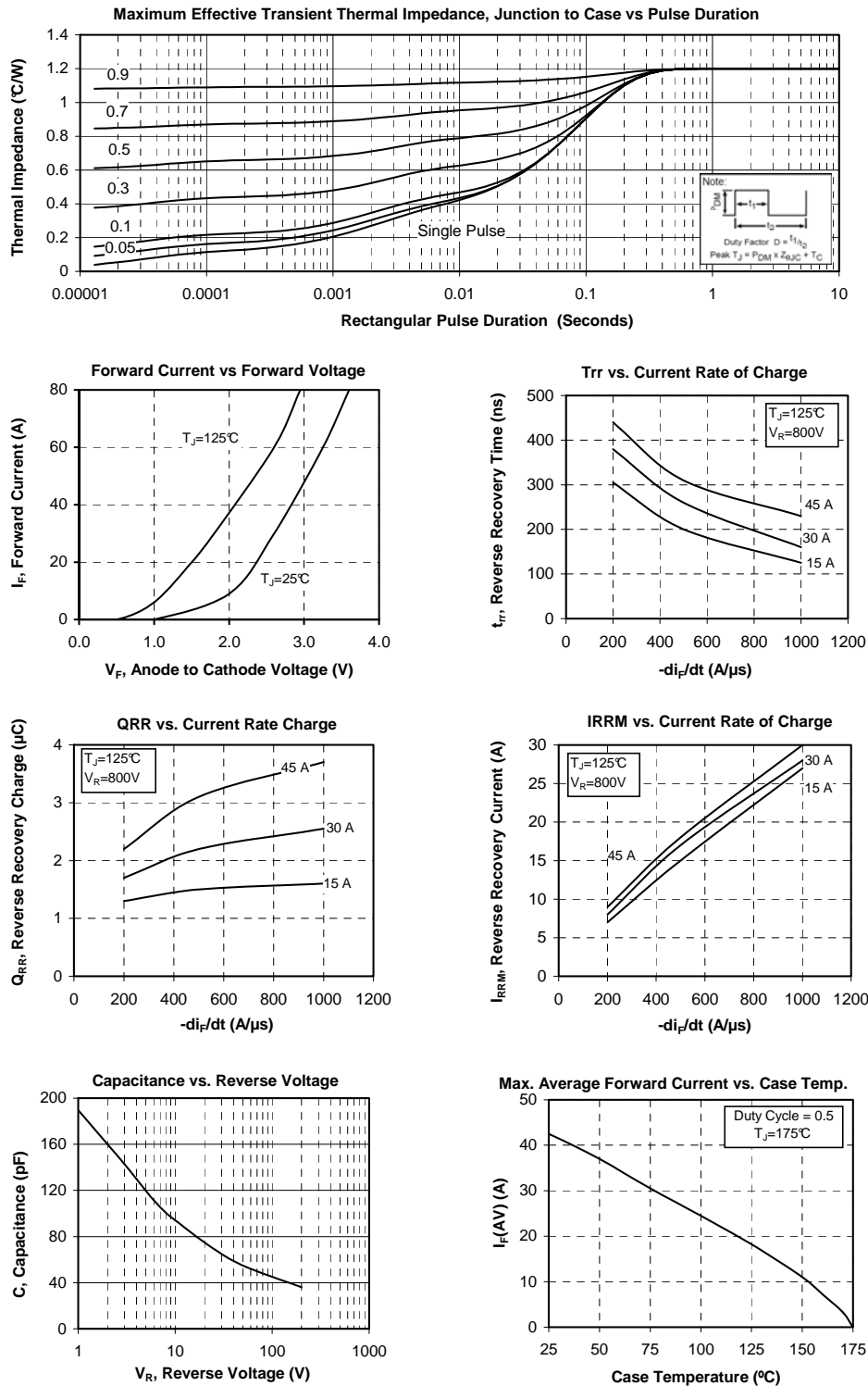

Microsemi reserves the right to change, without notice, the specifications and information contained herein

Microsemi's products are covered by one or more of U.S. patents 4,895,810 5,045,903 5,089,434 5,182,234 5,019,522 5,262,336 6,503,786 5,256,583 4,748,103 5,283,202 5,231,474 5,434,095 5,528,058 and foreign patents. U.S and Foreign patents pending. All Rights Reserved.