

DESCRIPTION

The LX1973B is a wide dynamic range light sensor with a very low dark current that is optimized for sensing low level light signals that typically occur under dark or darkening outdoor ambient lighting.

The LX1973B has been optimized for automotive systems such as headlamp brightness control or rear view mirror contrast control. Its radical (fractional exponent) response when interfaced with an 8 bit DAC can detect levels down to 0.001 Lux or levels as high as 500 Lux.

The spectral response of the integrated light sensor closely emulates the human eye so it ignores light such as infrared which emits energy but doesn't aid vision. This eliminates the need for an Infrared filter required with competitor's light sensors.

The LX1973B internal circuitry consists of a diode array with Microsemi's *Best Eye*™ processing that provides a nearly perfect photopic light wavelength response curve. The sensor output feeds into a wide dynamic range compression amplifier that provides accurate resolution over five decades of ambient light. The integrated dark current cancellation circuit facilitates accurate sensing of light below 0.01 Lux. The current source output of the LX1973B can be gain scaled using one external resistor.

The LX1973B is internally trimmed to an initial accuracy of 5% at room temperature and a light level of 10 Lux. Accuracy of 10% is maintained over the full temperature range (-40 to +85°C).

KEY FEATURES

- Nearly Perfect *Best Eye*™ Human Eye Spectral Response
- Dark Current < 0.0005 Lux (@ 25°C)
- 5 Decades Compressed Output
- 10% Accuracy Over Temperature
- Scalable Output Voltage
- No Optical Filters Needed

APPLICATIONS

- Auto Headlamp Control
- Auto Mirror Contrast Control

IMPORTANT: For the most current data, consult MICROSEMI's website: <http://www.microsemi.com>
Protected By US Patents: 6,787,757; Patents Pending

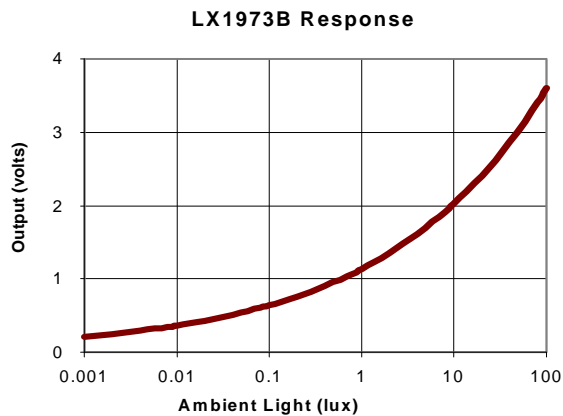
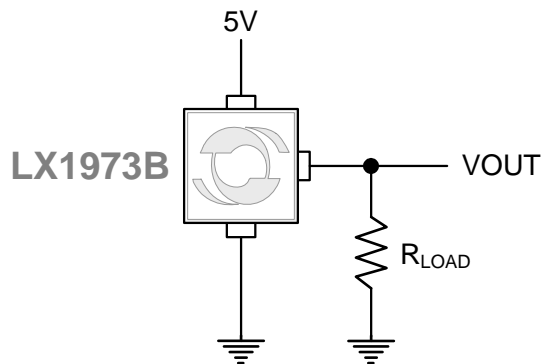
PRODUCT HIGHLIGHT

PACKAGE ORDER INFO

T _A (°C)	PL	Plastic MSOP Domed 8-Pin	PR	Plastic MSOP Domed 8-Pin Reverse Form
		RoHS Compliant / Pb-free, NiPdAu Finish		RoHS Compliant / Pb-free, NiPdAu Finish
-40 to 85	LX1973BIPL		LX1973BIPR	

Note: Available in Tape & Reel. Append the letters "TR" to the part number. (i.e. LX1973BIPL-xxxx-TR)

ABSOLUTE MAXIMUM RATINGS

V _{DD}	-0.3 to 6 V _{DC}
SNK/SRC (Output Compliance Voltage).....	-0.3 to V _{DD} + 0.3V _{DC}
SNK/SRC (Maximum Output Current).....	Internally Limited
Operating Temperature Range	-40 to +85°C
Storage Temperature Range.....	-40 to +100°C
RoHS / Pb-free Peak Package Solder Reflow Temperature (40 seconds maximum exposure).....	240°C (+0, -5)

Notes:

- Exceeding these ratings could cause damage to the device. All voltages are with respect to Ground. Currents are positive into, negative out of specified terminal.

THERMAL DATA

- PL** Plastic MSOP Domed 8-Pin
PR Plastic MSOP Domed 8-Pin Reverse Form

THERMAL RESISTANCE-JUNCTION TO CASE, θ_{JC}	39°C/W
THERMAL RESISTANCE-JUNCTION TO AMBIENT, θ_{JA}	206°C/W

Junction Temperature Calculation: $T_J = T_A + (P_D \times \theta_{JA})$.

The θ_{JA} numbers are guidelines for the thermal performance of the device / pc-board system. All of the above assume no ambient airflow.

FUNCTIONAL PIN DESCRIPTION

Name	Pin	Description
V _{DD}	1	Power Supply Voltage
V _{SS}	8	Ground Reference for Power and Signal Output
OUT	4	Output Current

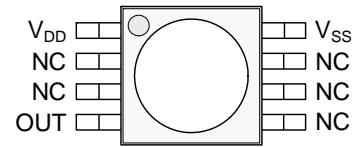
PACKAGE PIN OUT

PL PACKAGES
(Top View)

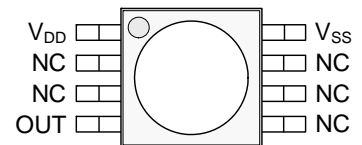
PL PACKAGE MARKING
(Bottom View)

PR PACKAGE MARKING
(Top View)

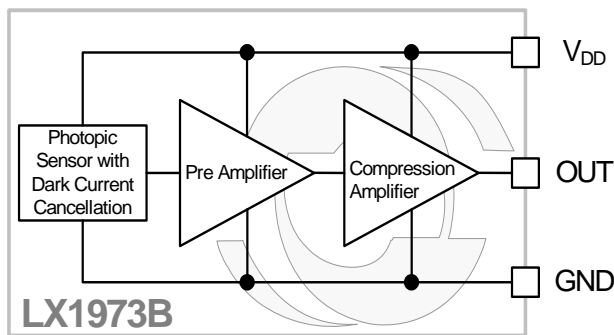
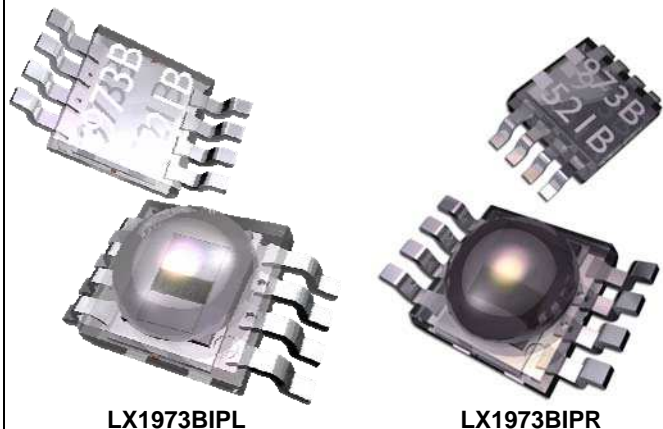
PR PACKAGES
(Bottom View)

NC – No Connection
 MSL3/240°C/168 Hours

SIMPLIFIED BLOCK DIAGRAM

Figure 1 – Simplified Block Diagram
PACKAGE

LX1973BIPL
LX1973BIPR

ELECTRICAL CHARACTERISTICS

The following specifications apply over the operating ambient temperature $-40^{\circ}\text{C} \leq T_A \leq 85^{\circ}\text{C}$ except where otherwise noted and the following test conditions: See Note 1, $V_{DD} = 5\text{V}$, $R_{OUT} = 10\text{k}$.

Parameter	Symbol	Test Conditions	LX1973B			Units
			Min	Typ	Max	
Operational Voltage	V_{DD}		4.5		5.5	V
Supply Current	I_{DD}	@ 1 Lux		0.22	0.27	mA
Power Supply Rejection Ratio	PSRR	$V_{RIPPLE} = 100\text{mV}_{P-P}$, $f = 10\text{kHz}$; $C_{OUT} = 0.1\mu\text{F}$	30	35		dB
Peak Spectral Response	λ_{PR}			580		nm
Infrared Response	$\frac{I_{DD}(\lambda)}{I_{DD}(\lambda_{PR})}$	$E_{V(\text{white})} = 100\text{ Lux}$, $E_{V(810\text{nm})} = 14.6\mu\text{Watt}/\text{cm}^2$, Note 3	-5	1	5	%
Light to Current Gain	G_L	See application section for equation				
Saturation Current	I_{SAT}		520			μA
Dynamic Response Time (to 10% Settling Error Point)	T_{DR}	1.0 Lux to 0.01 Lux		0.63	1.25	sec
		0.01 Lux to 1.0 Lux		0.2	0.5	sec
▶ Dome Top Package						
Output Current	$I_{OUT(0.01)}$	$E_V = 0.01\text{ Lux @ } 25^{\circ}\text{C}$, Note 1,2	36	40	44	μA
Output Current	$I_{OUT(1.0)}$	$E_V = 1.0\text{ Lux}$, Note 1,2	114	126	139	μA
Output Current	$I_{OUT(10)}$	$E_V = 10\text{ Lux}$, Note 1,2	202	224	246	μA
Output Current	$I_{OUT(100)}$	$E_V = 100\text{ Lux}$, Note 1,2	369	410	451	μA
Dark Current (Equivalent Lux)	$I_{OUT(DARK)}$	$E_V = 0\text{ Lux}$, $T_A = 20^{\circ}\text{C}$, Note 4		190	380	μLux
		$E_V = 0\text{ Lux}$, $T_A = 50^{\circ}\text{C}$, Note 4		700	1400	
▶ Dome Bottom Package						
Output Current	$I_{OUT(0.01)}$	$E_V = 0.01\text{ Lux @ } 25^{\circ}\text{C}$, Note 1,2	36	40	44	μA
Output Current	$I_{OUT(1.0)}$	$E_V = 1.0\text{ Lux}$, Note 1,2	112	124	137	μA
Output Current	$I_{OUT(10)}$	$E_V = 10\text{ Lux}$, Note 1,2	201	223	245	μA
Output Current	$I_{OUT(100)}$	$E_V = 100\text{ Lux}$, Note 1,2	365	405	445	μA
Dark Current (Equivalent Lux)	$I_{OUT(DARK)}$	$E_V = 0\text{ Lux}$, $T_A = 20^{\circ}\text{C}$, Note 4		190	380	μLux
		$E_V = 0\text{ Lux}$, $T_A = 50^{\circ}\text{C}$, Note 4		700	1400	

Notes:

- The input irradiance is supplied from a point source which is a white light emitting diode (LED); Fairchild Semiconductor part number MV8W00.
- See Figure 2.
- See Figure 3.

4. Dark Current equivalent Lux at 0 Lux: $EL = \left[\frac{I_{OUT}}{I_{REF}} \right]^4 \div (146 \times 10^{-9})$

For Dome Top Package, $I_{REF} = 6446\mu\text{A}$.

For Dome Bottom Package, $I_{REF} = 6344\mu\text{A}$.

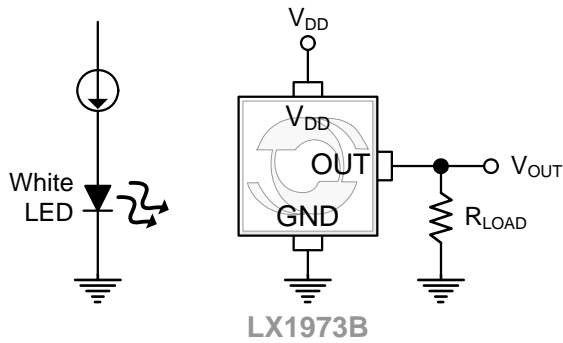
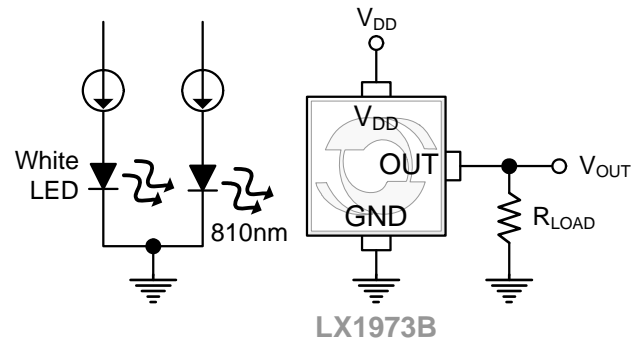
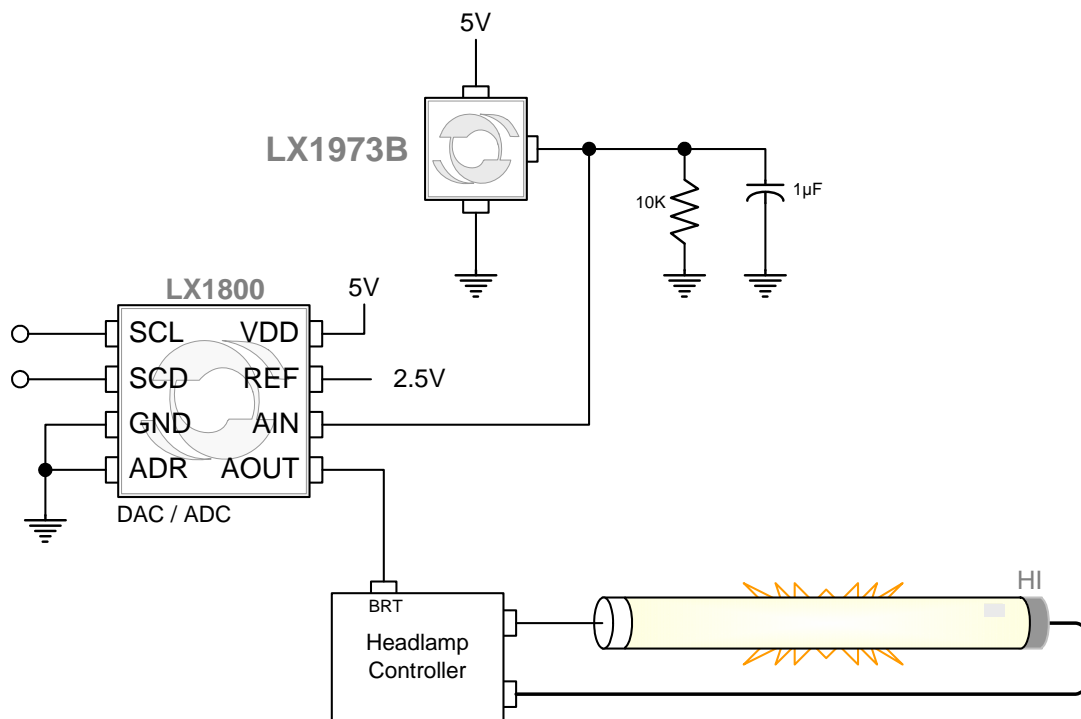
TEST CIRCUITS

Figure 2 – Operational Voltage Measurement Circuit

Figure 3 – IR Sensitivity Measurement Circuit
APPLICATION CIRCUITS

Figure 4 – Typical Application



APPLICATIONS

GENERAL DESCRIPTION

The LX1973B produces an output current that is sensitive to the level of ambient light that falls onto the photosensitive area of the IC package. The sensitivity is amplified and compressed to provide ratio metric accuracy across several decades. The sensitivity function is:

$$I_{OUT}(P) = \frac{I_{ref}}{1 \text{ Lux}} \times [E_{DARK} + E_{AMBIENT}]^{0.25}$$

$$1 \text{ Lux}^{0.25} = 1^{0.25}$$

$I_{ref} = 126\mu\text{A}$ for the Domed Top Package

$I_{ref} = 124\mu\text{A}$ for the Domed Bottom Package

E_{DARK} = dark current equivalent Lux expressed in Lux from a white LED point source.

$E_{AMBIENT}$ = ambient illumination expressed in Lux from a white LED point source.



SENSITIVITY

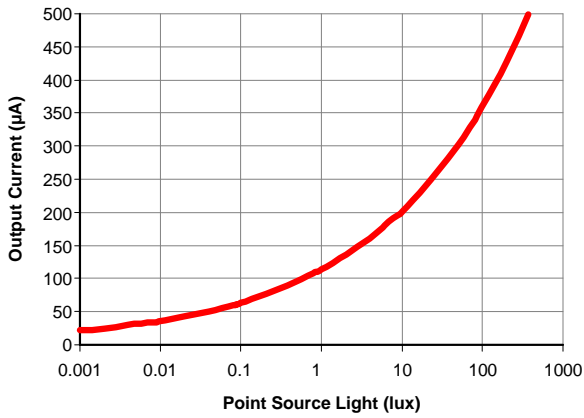

DARK CURRENT VS TEMP

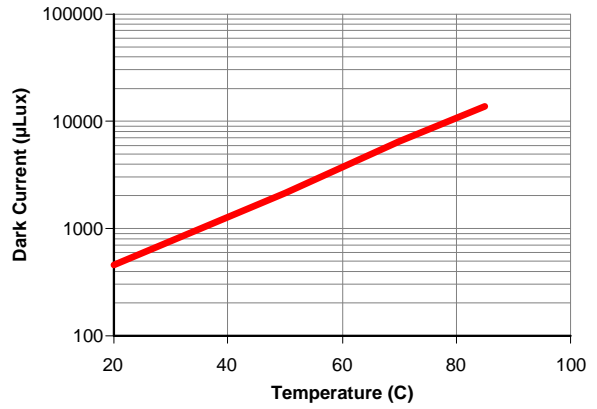

NORMALIZED (PRE COMPRESSION)

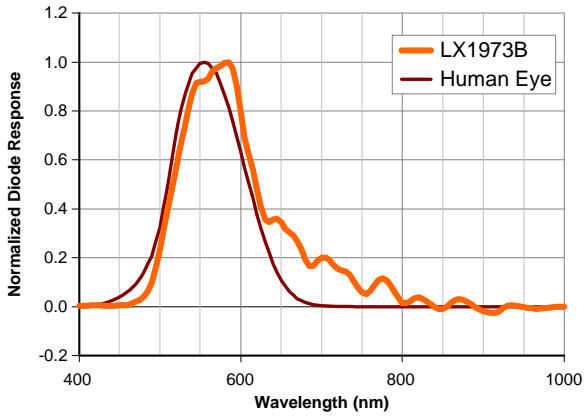

100 LUX OUTPUT VOLTAGE

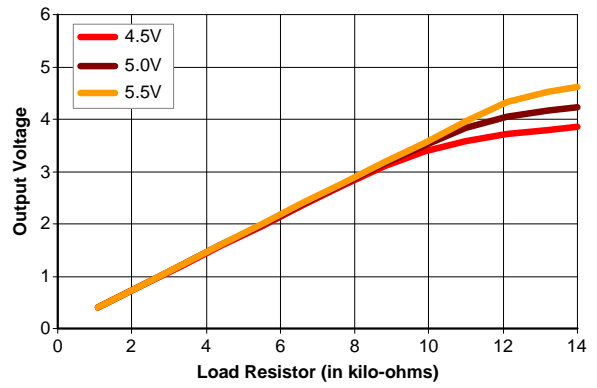

I_{OUT} VS TEMPERATURE & V_{DD}

*I*_{out} vs Temperature @ 10 lux

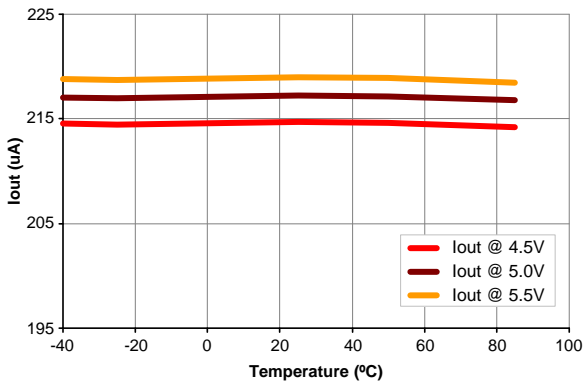

I_{OUT} STEP RESPONSE

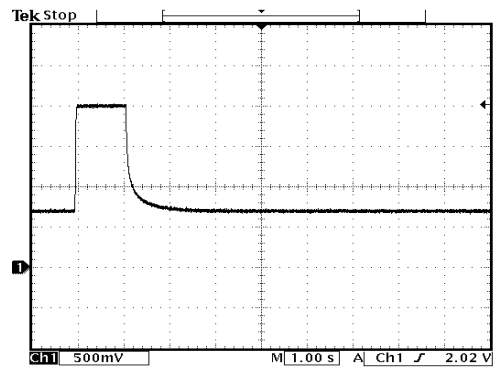

8 Mar 2005 15:27:13

Load = 10k and 0µF;
Photo Step = Direct Light Input of 1 Lux to 0.01 Lux.

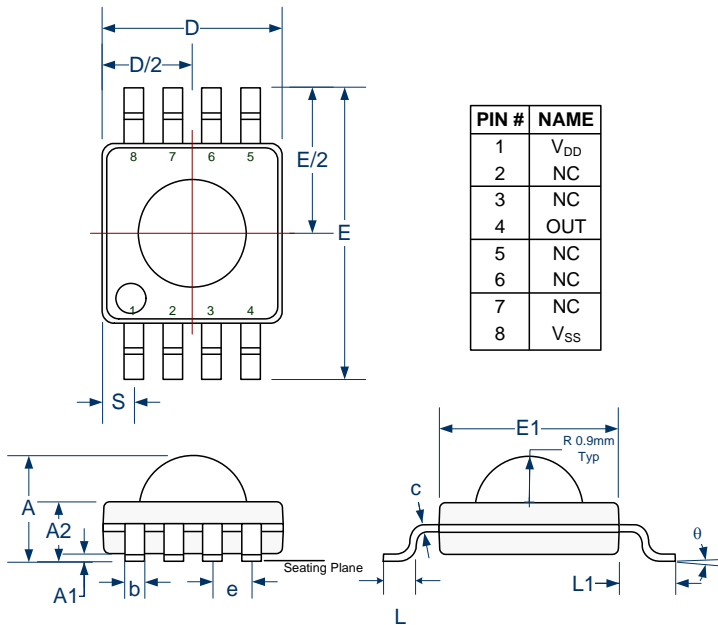
PACKAGE DIMENSIONS
PL 8-Pin Miniature Shrink Outline Package (MSOP) Dome Top

Dim	MILLIMETERS		INCHES	
	MIN	MAX	MIN	MAX
A	1.60	1.85	0.063	0.073
A1	0.05	0.15	0.002	0.006
A2	-	1.10	-	0.043
b	0.26	0.41	0.010	0.016
c	0.13	0.23	0.005	0.009
D	2.90	3.10	0.114	0.122
E	4.75	5.05	0.187	0.199
E1	2.90	3.10	0.114	0.122
e	0.65 BSC		0.026 BSC	
L	0.41	0.71	0.016	0.028
L1	0.95 REF		0.037 REF	
S	0.525 REF		0.021 REF	
θ	3°		3°	

Note:

- Dimensions do not include mold flash or protrusions; these shall not exceed 0.155mm(.006") on any side. Lead dimension shall not include solder coverage.

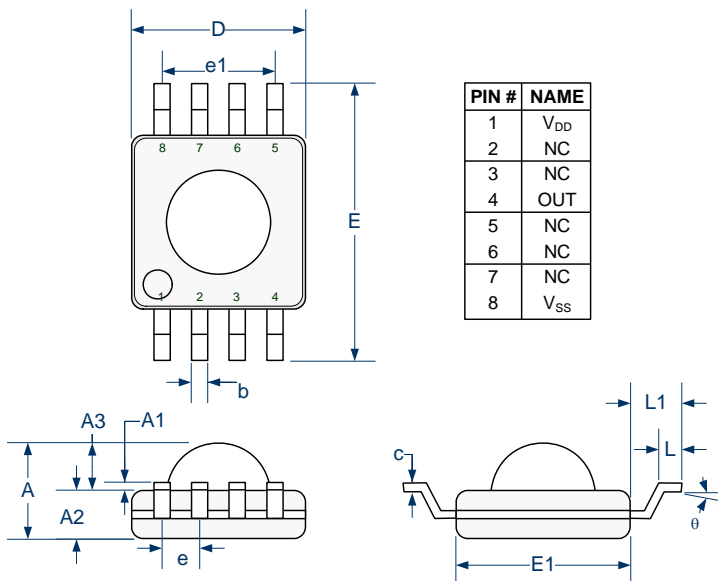
PR 8-Pin Plastic MSOP Clear Package Inverted Dome

Dim	MILLIMETERS		INCHES	
	MIN	MAX	MIN	MAX
A	-	1.68	-	0.066
A1	0.05	0.15	0.002	0.006
A2	0.81	0.92	0.032	0.036
A3	0.66	0.76	0.026	0.030
b	0.26	0.41	0.010	0.016
c	0.13	0.23	0.005	0.009
D	2.90	3.10	0.114	0.122
E	4.75	5.05	0.187	0.199
E1	2.90	3.10	0.114	0.122
e	0.65 BSC		0.026 BSC	
e1	1.95 TYP		0.077 TYP	
L	0.41	0.71	0.016	0.028
L1	0.95 REF		0.037 REF	
θ	5°		5°	



PACKAGE DIMENSIONS (CONTINUED)

Light Footprint

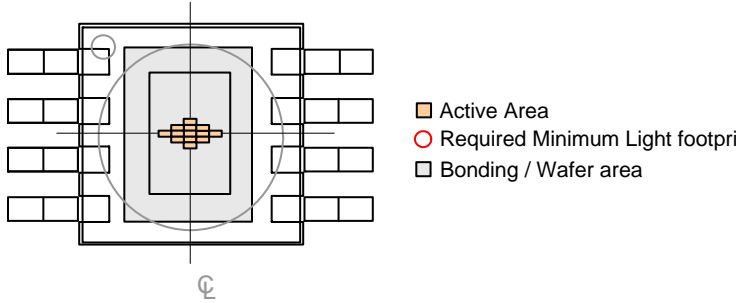

Dim	MILLIMETERS	INCHES
P1	1.8	0.070
P2	2.5	0.098

Note:

P2 represents a possible light footprint and its dimensions are not subject to strict tolerances. Only P1 is required to be covered with light. This larger footprint is designed to ensure coverage of the device's active area.

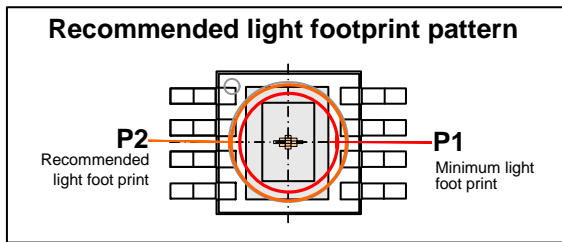
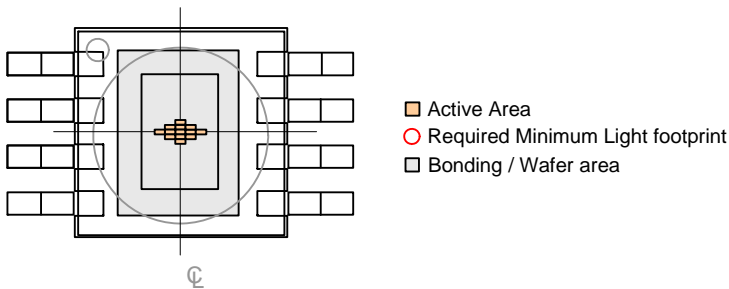
**Dome Top Package**

Dim	MILLIMETERS	INCHES
P1	1.8	0.070
P2	2.5	0.098
P3	2.9	0.114

Note:

P2 represents a possible light footprint and its dimensions are not subject to strict tolerances. Only P1 is required to be covered with light. This larger footprint is designed to ensure coverage of the device's active area.

P3 represents the minimum aperture through which the dome of the device would fit in the PCB.

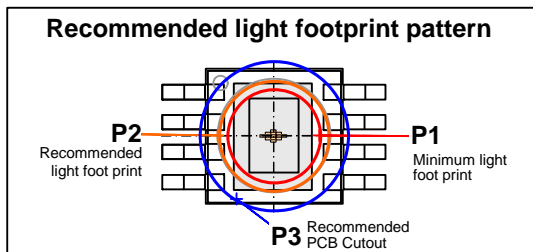
**Dome Bottom Package**

PRODUCTION DATA – Information contained in this document is proprietary to Microsemi and is current as of publication date. This document may not be modified in any way without the express written consent of Microsemi. Product processing does not necessarily include testing of all parameters. Microsemi reserves the right to change the configuration and performance of the product and to discontinue product at any time.