

DESCRIPTION

The LX1973 is a wide dynamic range light sensor with a very low dark current that is optimized for sensing low level light signals that typically occur under dark or darkening outdoor ambient lighting. The LX1973 has been optimized for automotive systems such as headlamp brightness control or rear view mirror contrast control. Its radical (fractional exponent) response when interfaced with an 8 bit DAC can detect levels down to 0.001 lux or levels as high as 500 lux.

The spectral response of the integrated light sensor closely emulates the human eye so it ignores light such as infrared which emits energy but doesn't aid vision. This eliminates the need for an Infrared filter required with competitor's light sensors.

The LX1973 internal circuitry consists of a diode array that provides a nearly perfect photopic light wavelength response curve. The sensor output feeds into a wide dynamic range compression amplifier that provides accurate resolution over five decades of ambient light. The integrated dark current cancellation circuit facilitates accurate sensing of light below 0.01 lux. The current source output of the LX1973 can be gain scaled using one external resistor.

The LX1973 is internally trimmed to an initial accuracy of 5% at room temperature and a light level of 10lux. Accuracy of 10% is maintained over the full temperature range (-40 to +85C).

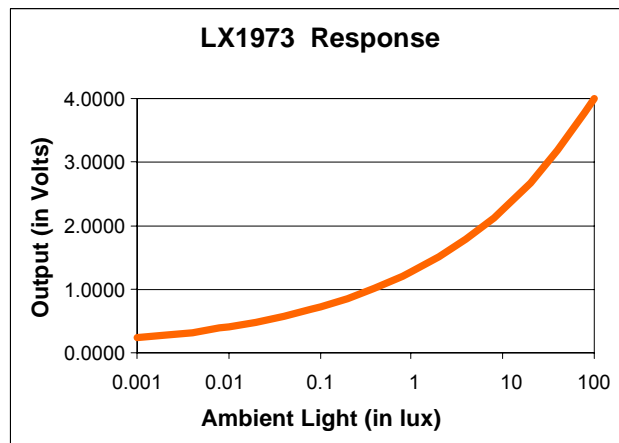
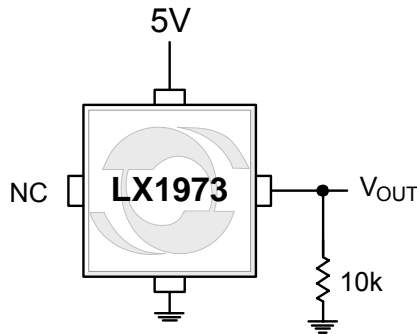
KEY FEATURES

- Human Eye Spectral Response
- 25C Dark Current < 0.005 lux
- 5 Decades Compressed Output
- 10% Accuracy Over Temperature
- Scalable Output Voltage
- No Optical Filters Needed

APPLICATIONS

- Auto Headlamp Control
- Auto Mirror Contrast Control

IMPORTANT: For the most current data, consult MICROSEMI's website: <http://www.microsemi.com>
 Protected by US Patent: 6,787,757; Patents Pending

PRODUCT HIGHLIGHT

PACKAGE ORDER INFO

T_A (°C)	DU	Plastic MSOP
		8-pin
		RoHS Compliant / Pb-free
-40 to 85	LX1973IDU	

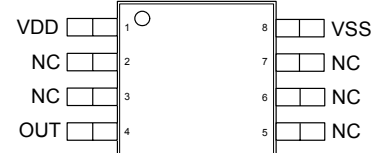
Note: Available in Tape & Reel. Append the letters "TR" to the part number. (i.e. LX1973IDU-TR)

ABSOLUTE MAXIMUM RATINGS

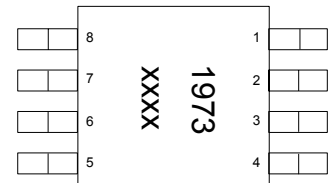
V _{DD}	-0.3 to 6 V _{DC}
SNK/SRC (Output Compliance Voltage).....	-0.3 to V _{DD} + 0.3V _{DC}
SNK/SRC (Maximum Output Current).....	Internally Limited
Maximum Operating Junction Temperature	150°C
Operating Temperature Range	-40 to +85°C
Storage Temperature Range	-55 to 125°C
Peak Package Solder Reflow Temp. (40 seconds maximum exposure).....	260° (+0, -5)

Notes: Exceeding these ratings could cause damage to the device. All voltages are with respect to Ground. Currents are positive into, negative out of specified terminal.

Solder reflow to follow: IPC/JEDEC J-STD-020B 7/02 Pb-SN Small Body Profile

PACKAGE PIN OUT


DU PACKAGE
(Top View)



PACKAGE MARKING
(Bottom View)

xxxx – Denotes Date Code / Lot information

RoHS / Pb-free 100% matte Tin Lead Finish

THERMAL DATA
DU Plastic MSOP 8-Pin

THERMAL RESISTANCE-JUNCTION TO CASE, θ_{JC}	39°C/W
THERMAL RESISTANCE-JUNCTION TO AMBIENT, θ_{JA}	206°C/W

Junction Temperature Calculation: $T_J = T_A + (P_D \times \theta_{JA})$.

The θ_{JA} numbers are guidelines for the thermal performance of the device/pc-board system. All of the above assume no ambient airflow.

FUNCTIONAL PIN DESCRIPTION

Name	Description
VDD	Input Supply Voltage
VSS	Ground Reference for Power and Signal Output
OUT	Output Current
VDD	Input Supply Voltage

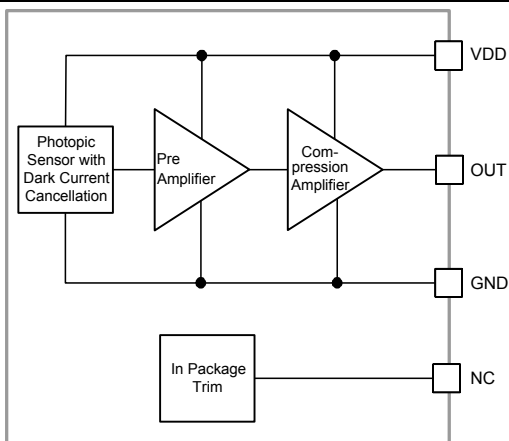
SIMPLIFIED BLOCK DIAGRAM


Figure 1 – Simplified Block Diagram

PACKAGE PHOTO


ELECTRICAL CHARACTERISTICS

Unless otherwise specified, the following specifications apply over the operating ambient temperature $-40^{\circ}\text{C} \leq T_A \leq 85^{\circ}\text{C}$ except where otherwise noted and the following test conditions: See Note 1, $V_{DD} = 5\text{V}$, $R_{OUT} = 10\text{k}$.

Parameter	Symbol	Test Conditions	LX1973			Units
			Min	Typ	Max	
Operational Voltage	V_{DD}		4.5		5.5	V
Supply Current	I_{DD}	$E_V = 1 \text{ lux}$		0.2	0.25	mA
Power Supply Rejection Ratio	PSRR	$V_{RIPPLE} = 100\text{mV}_{P-P}$, $f = 10\text{kHz}$; $C_{OUT} = 0.1\mu\text{F}$	30	35		dB
Peak Spectral Response	λ_{PR}			550		nm
Infrared Response	$\frac{I_{DD}(\lambda)}{I_{DD}(\lambda_{PR})}$	$E_V(550\text{nm}) = E_V(800\text{nm}) = 146\text{nW/cm}^2$, Note 3	-5	1	5	%
Light to Current Gain	G_L	See application section for equation				
Output Current	$I_{OUT(0.01)}$	$E_V = 0.01 \text{ lux @ } 25^{\circ}\text{C}$	34	38	42	μA
Output Current	$I_{OUT(1.0)}$	$E_V = 1 \text{ lux}$, Note 2	108	120	132	μA
Output Current	$I_{OUT(100)}$	$E_V = 100 \text{ lux}$, Note 2	342	380	418	μA
Saturation Current	I_{SAT}		650			μA
Dark Current (Equivalent lux)	$I_{OUT(DARK)}$	$E_V = 0 \text{ lux}$, $T_A = 20^{\circ}\text{C}$, Note 4 $E_V = 0 \text{ lux}$, $T_A = 50^{\circ}\text{C}$, Note 4		450 2100	900 10000	μLux
Dynamic Response Time	T_{DR}	10% settling error (146 nW/cm^2 to 1.46 nW/cm^2 step response)		1.5	3	sec
Radiant Sensitive Area				0.20		mm^2

Notes:

- The input irradiance (E_V) is supplied from a white light-emitting diode (LED) optical source adjusted to impose the specified E_V at $\lambda = 550\text{nm}$.
- See Figure 1.
- See Figure 2.

- Dark Current equivalent lux at 0 lux: $EL = \left[\frac{I_{OUT}}{6163\mu\text{A}} \right]^4 \div 146 \times 10^{-9}$

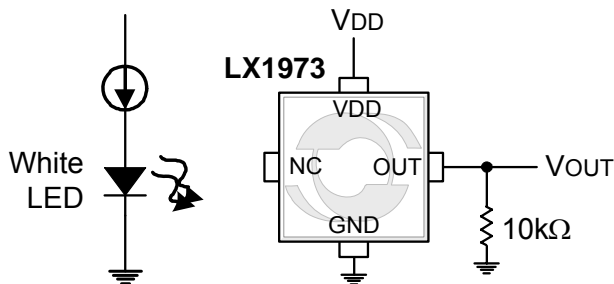
TEST CIRCUITS


Figure 2 – Operational Voltage Measurement Circuit

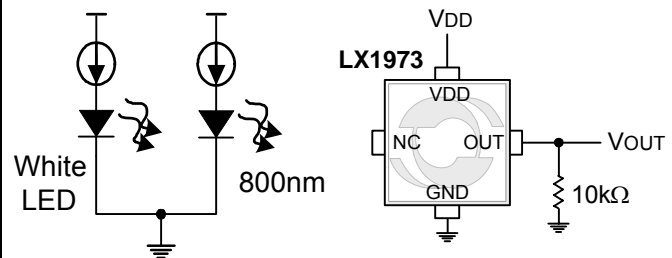
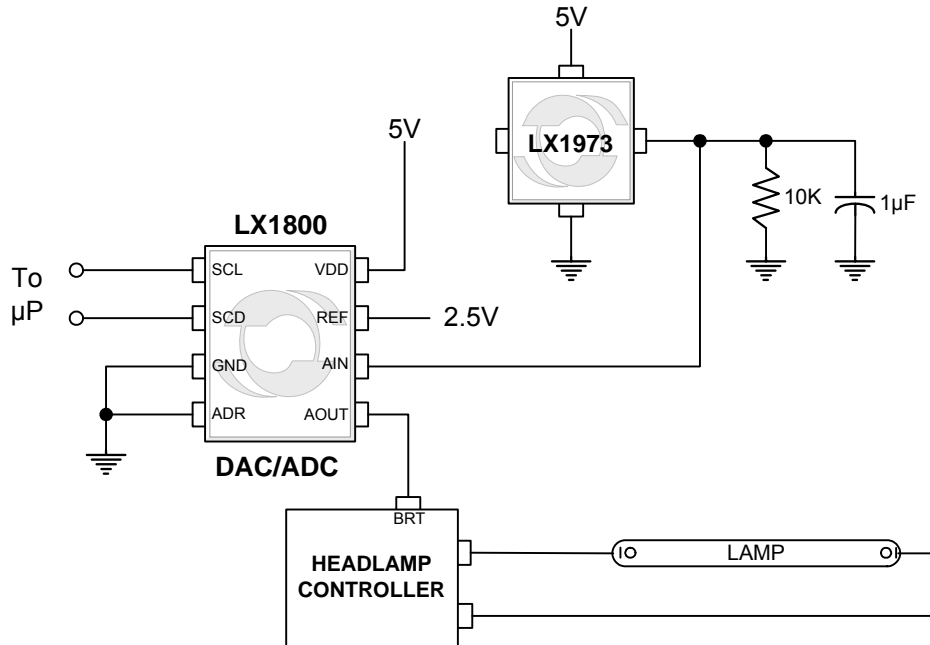


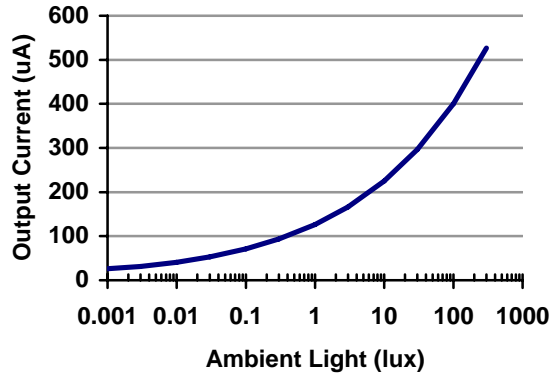
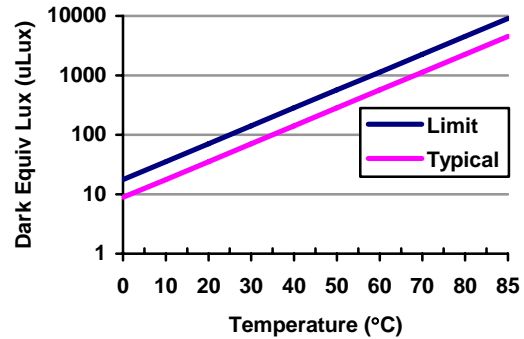
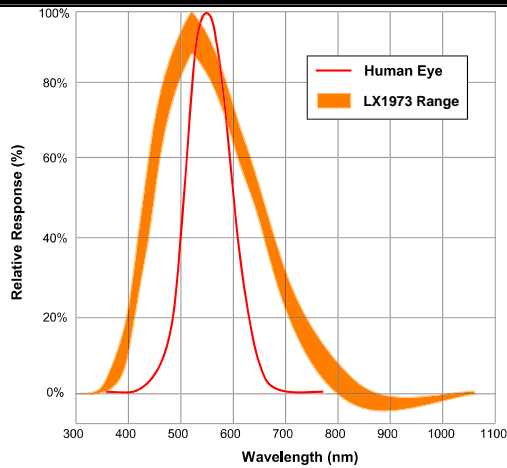
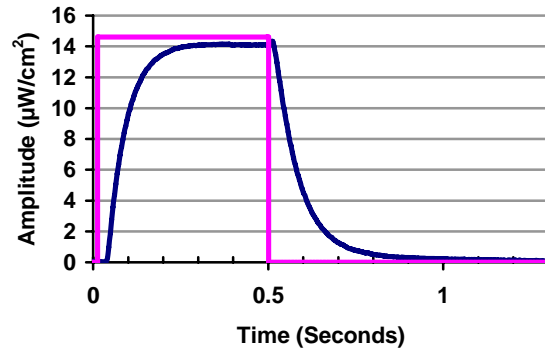
Figure 3 – IR Sensitivity Measurement Circuit

APPLICATION CIRCUITS

Figure 4 – Typical Application
APPLICATION CIRCUITS
GENERAL DESCRIPTION

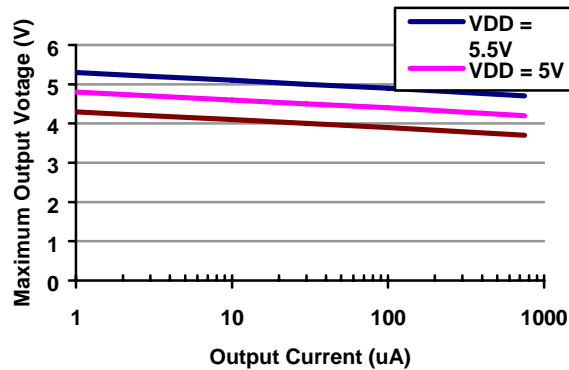
The LX1973 produces an output current that is sensitive to the level of ambient light that falls onto the photosensitive area of the IC package. The sensitivity is amplified and compressed to provide ratio metric accuracy across several decades. The sensitivity function is:

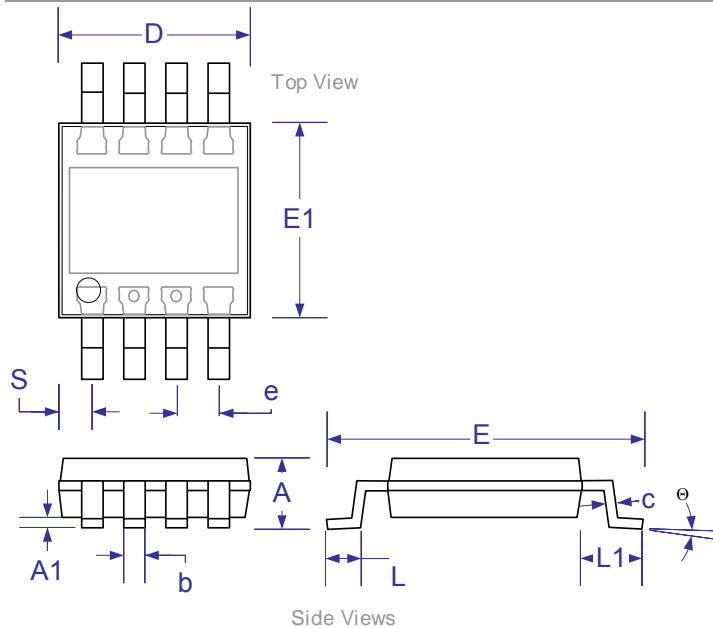
$$I_{OUT}(P) = \frac{6163\mu A}{\left(\frac{W}{cm^2}\right)^{0.25}} \times [P_{DARK} + P_{AMBIENT}]^{0.25}$$

where P_{DARK} is the dark current equivalent power and $P_{AMBIENT}$ is the ambient illumination both expressed in W/cm^2 at a 555nm wavelength. P_{DARK} is approximately $7pW/cm^2$ at $25^\circ C$.

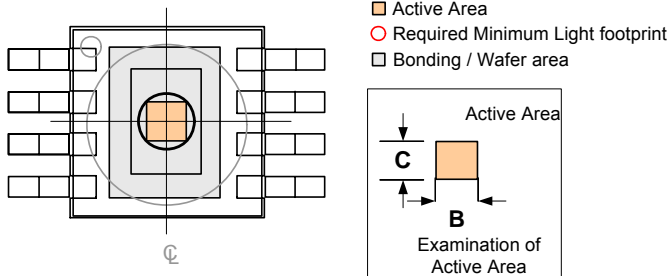
SENSITIVITY

DARK CURRENT VS TEMP

RESPONSE VS WAVELENGTH

I_{OUT} STEP RESPONSE


Load = 3.8kΩ and 1μF
Photo Step = Direct Light Input of 14.6μW/cm²

MAXIMUM OUTPUT VOLTAGE


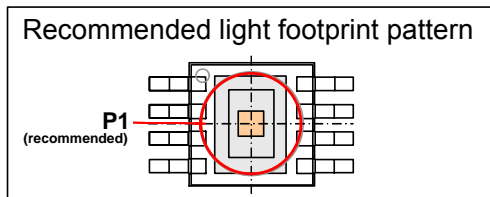
PACKAGE DIMENSIONS
DU 8-Pin Miniature Shrink Outline Package (MSOP)


Dim	MILLIMETERS		INCHES	
	MIN	MAX	MIN	MAX
A	—	1.10	—	0.043
A1	0.05	0.15	0.002	0.006
b	0.26	0.41	0.010	0.016
c	0.13	0.23	0.005	0.009
D	2.90	3.10	0.114	0.122
e	0.65 BSC		0.025 BSC	
E	4.75	5.05	0.187	0.198
E1	2.90	3.10	0.114	0.122
L	0.41	0.71	0.016	0.028
L1	0.95 BSC		0.037 BSC	
S	0.525 BSC		0.021 BSC	
θ	3°		3°	



Dim	MILLIMETERS	INCHES
	A	1.22
a	0.85	0.033
B	0.60	0.024
C	0.60	0.024

P1	2.5	0.98
----	-----	------


Note:

P1 represents a possible light footprint and its dimensions are not subject to strict tolerances. Only the active area of the device is required to be covered with light. This larger footprint is designed to ensure coverage of the device's active area.



Microsemi[®]

LX1973

Automotive Light Sensor

PRODUCTION DATA SHEET

NOTES

PRODUCTION DATA – Information contained in this document is proprietary to Microsemi and is current as of publication date. This document may not be modified in any way without the express written consent of Microsemi. Product processing does not necessarily include testing of all parameters. Microsemi reserves the right to change the configuration and performance of the product and to discontinue product at any time.