

DESCRIPTION

The LX1972 is a low cost silicon light sensor with spectral response that closely emulates the human eye.

Patented circuitry produces peak spectral response at 520nm, with IR response less than $\pm 5\%$, of the peak response, above 900nm.

The photo sensor is a PIN diode array with a linear, accurate, and very repeatable current transfer function. High gain current mirrors on the chip multiply the PIN diode photo-current to a sensitivity level that can be voltage scaled with a standard value external resistor. Output current from this simple to use two-pin device can be used directly or converted to a voltage by placing it in series with a single resistor at either of its two pins.

Dynamic range is determined by the resistors (typically in the range of 10K to 100K) and power supply values. Typically the LX1972 needs only 1.8V of headroom to operate at 1000 Lux illumination.

Internal temperature compensation allows dark current to be kept below 200nA over the full specification temperature range (-40 to +85°C), providing high accuracy at low light levels. Usable ambient light conditions range is from 1 to more than 5000 Lux.

The LX1972 is optimized for controlling back lighting systems in low cost consumer products such as LCD TV, portable computers, and digital cameras.

KEY FEATURES

- Near Human Eye Spectral Response
- Very Low IR Sensitivity
- Highly Accurate & Repeatable Output Current vs. Light
- Scalable Output Voltage
- Temperature Stable
- Integrated High Gain Photo Current Amplifiers
- No Optical Filters Needed

APPLICATIONS

- Portable Electronic Displays
- LCD TV Backlight Systems
- Digital Still Cameras (DSC)
- Desk top Monitors
- Notebook Computers

IMPORTANT: For the most current data, consult MICROSEMI's website: <http://www.microsemi.com>
Protected By U.S. Patents: 6,787,757; Patents Pending

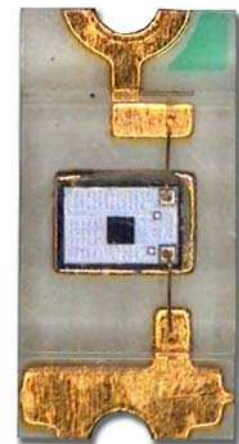
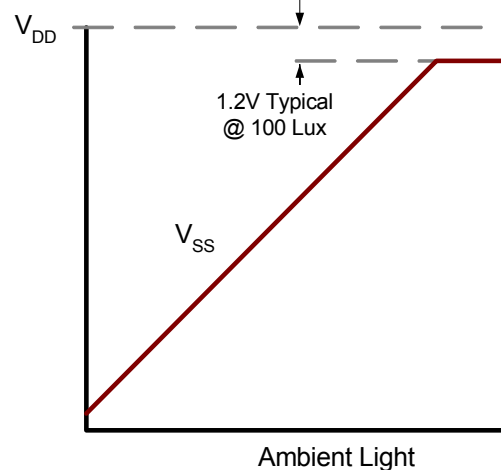
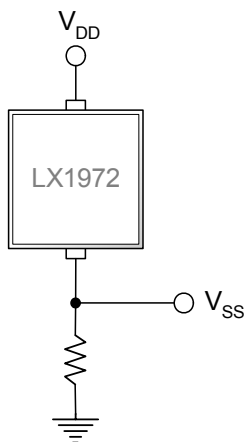
PRODUCT HIGHLIGHT

LX1972 Top View

PACKAGE ORDER INFO

T_A (°C)	BC Plastic 1206 2-Pin
	RoHS Compliant / Pb-free
-40 to 85	LX1972IBC

Note: Available in Tape & Reel. Append the letters "TR" to the part number. (i.e. LX1972IBC-TR)

ABSOLUTE MAXIMUM RATINGS

Supply Input Voltage -0.3V to 6V
 Ground Current Internally Limited
 Operating Temperature Range -40°C to 85°C
 Maximum Operating Junction Temperature 150°C
 Storage Temperature Range -40°C to +100°C
 RoHS / Pb-free Peak Package Solder Reflow Temperature
 (40 second maximum exposure) 260°C (+0, -5)

Note: Exceeding these ratings could cause damage to the device. All voltages are with respect to Ground. Currents are positive into, negative out of specified terminal.

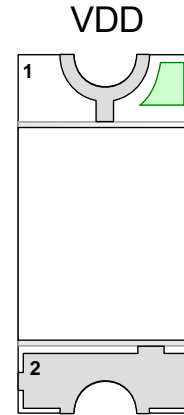
PACKAGE PIN OUT

VDD
 VSS
 BC PACKAGE
 (Top View)

RoHS / Pb-free Gold Lead Finish

THERMAL DATA
BC Plastic 1206 2-Pin

THERMAL RESISTANCE-JUNCTION TO AMBIENT, θ_{JA}	850°C/W
-------------------------------------------------------	----------------

Junction Temperature Calculation: $T_J = T_A + (P_D \times \theta_{JA})$.

The θ_{JA} numbers are guidelines for the thermal performance of the device/pc-board system. All of the above assume no ambient airflow.

FUNCTIONAL PIN DESCRIPTION

Name	Description
VDD	Positive Terminal
VSS	Negative Terminal

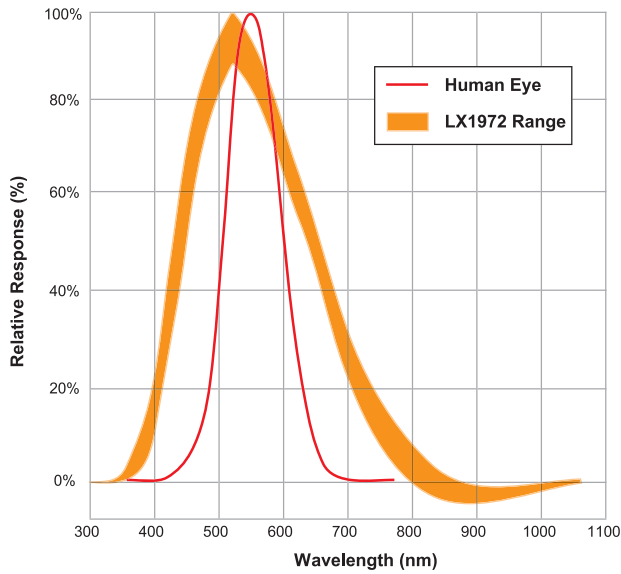
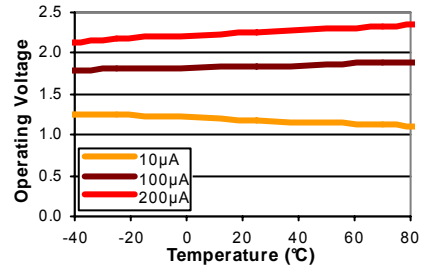
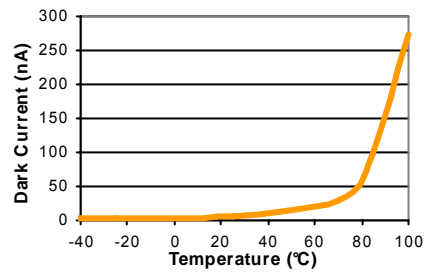
CHARACTERISTIC CURVES

Chart 1 – Response vs. wavelength

Chart 2 – Typical Operating Voltage Vs VSS Current

Chart 3 – Dark Leakages Vs. Temperature

ELECTRICAL CHARACTERISTICS

Unless otherwise specified, the following specifications apply over the operating ambient temperature $-40^{\circ}\text{C} \leq T_A \leq 85^{\circ}\text{C}$ except where otherwise noted and the following test conditions: See Note 1, $V_{DD} = 5\text{V}$, $R_{SS} = 10\text{K}$

Parameter	Symbol	Test Conditions	LX1972			Units
			Min	Typ	Max	
RESPONSE						
Peak Spectral Response	λ_{PR}			520		nm
Infrared Response	$\frac{I_{DD}(\lambda)}{I_{DD}(\lambda_{PR})}$	$E_V(550\text{nm}) = 292\mu\text{W}/\text{cm}^2$, Current responsivity change with additional direct light input of $292\mu\text{W}/\text{cm}^2$ at 910nm, Note 3	5	1	5	%
Minimum Operational Voltage	$V_{DD}-V_{SS}$	$E_V = 14.6\mu\text{W}/\text{cm}^2$, $I_{SS} = 10\mu\text{A}$		1.2	1.4	V
		$E_V = 146\mu\text{W}/\text{cm}^2$, $I_{SS} = 100\mu\text{A}$		1.8	2.1	
		$E_V = 292\mu\text{W}/\text{cm}^2$, $I_{SS} = 200\mu\text{A}$		2.2	2.6	
Light Current	I_{SS}	$E_V = 14.6\mu\text{W}/\text{cm}^2$, Note 2	7.5	10	12.5	μA
		$E_V = 146\mu\text{W}/\text{cm}^2$, Note 2	75	100	125	
		$E_V = 292\mu\text{W}/\text{cm}^2$, Note 2;	150	200	250	
Gain Linearity		$14.6\mu\text{W}/\text{cm}^2 \leq E_V \leq 146\mu\text{W}/\text{cm}^2 @ 25^{\circ}\text{C}$	-15		15	%
Dark Current	$I_{DD}(\text{DARK})$	$E_V = 0\mu\text{W}/\text{cm}^2$, $T_A = 25^{\circ}\text{C}$		0.010	50	nA
		$E_V = 0\mu\text{W}/\text{cm}^2$			200	
Power Supply Rejection Ratio	PSRR	$V_{\text{RIPPLE}} = 10\text{mV}_{P-P}$, $f = 10\text{kHz}$		-25		dB
Radiant Sensitive Area				0.04		mm^2

Notes:

- The input irradiance (E_V) is supplied from a white light-emitting diode (LED) optical source adjusted to impose the specified E_V at a peak $\lambda = 550\text{nm}$.
- See Figure 1.
- See Figure 2.

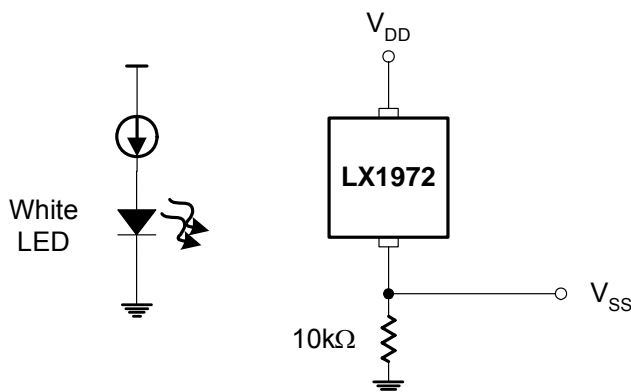
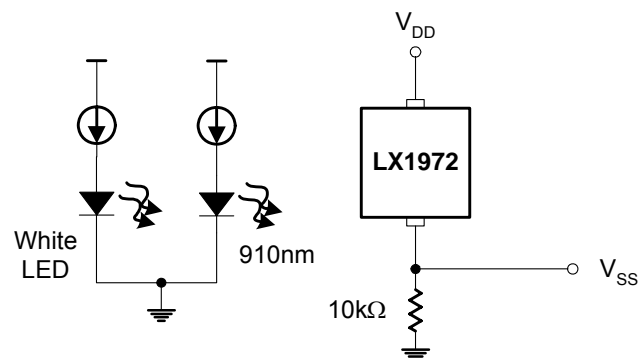
TEST CIRCUITS

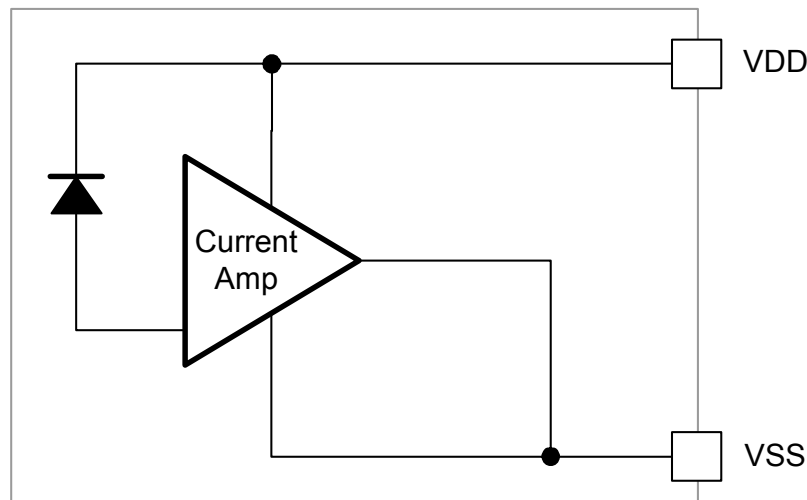
Figure 1 – Operational Voltage Measurement Circuit

Figure 2 – IR Sensitivity Measurement Circuit

SIMPLIFIED BLOCK DIAGRAM

Figure 3 – Simplified Block Diagram
APPLICATION NOTE
LIGHT UNITS

In converting from $\mu\text{W}/\text{cm}^2$ to lux it is necessary to define the light source. Lux is a unit for the measurement of illuminance, which is the photometric flux density or visible light flux density. Whereas $\mu\text{W}/\text{cm}^2$ is a measurement of irradiance or the measurement of electromagnetic radiation, flux both visible and invisible. The first step in the conversion process is to convert irradiance to illuminance, which essentially involves running the irradiant flux through a photopic filter. In normal ambient, a photopic curve is used and in dark ambient, a scotopic curve (dark adapted eye) is used. If the light is composed of only one wavelength, a conversion chart will tell the conversion factor to convert $\mu\text{W}/\text{m}^2$ to lux (lumens/m²). If more than one wavelength is used, the light spectrum of the irradiance must be applied to the photopic filter to determine the resultant illuminance. The most sensitive wavelength for the normal light adapted human eye is 555nm, which corresponds to yellowish-green light. At 555nm, the conversion factor is $683 \text{ Lux} = 1\text{W}/\text{m}^2 = 100\mu\text{W}/\text{cm}^2$. Therefore $14.6\mu\text{W}/\text{cm}^2 = 100 \text{ lux}$ at 555nm.

If the photo sensor had a truly photopic response, it would produce the same output current for the same number of lux, regardless of the color of the light. However, because the match is not perfect, there is still wavelength dependency particularly at the ends of the visible spectrum.

In the case of the LX1972 the peak photo response is at 520nm, however depending on the light source, what the human eye perceives as 'white' light may actually be composed of peak wavelengths of light other than 520nm. For instance, a typical fluorescent lamp includes dominant light not only near 550nm but also at 404 and 435nm. Incandescent light sources such as standard tungsten lights generate substantial IR radiation out beyond 2000nm.

For ease of automatic testing of the LX1972 the ATE (automatic test equipment) light source is configured with white LED's whose current is adjusted to output a calibrated flux density at 550nm. This allows consistent and repeatable testing of the sensor but corresponds to a light source unlike that typically found in a office, home or sunlit environment. In practice, the user needs to place the sensor in the target environment and calibrate the sensors output current range to match the application objective. This is easily accomplished by adjusting the output resistor, which sets the sensor's gain.

APPLICATION EXAMPLES

The following examples present both fully automatic (no user input) and semi-automatic to fully manual override implementations. These general guidelines are applicable to a wide variety of potential light control applications. The LX1972 can be used to control the brightness input of CCFL inverters (like Microsemi's PanelMatch™ inverter family, or line of controller IC's). Likewise, it can interface well with LED drivers like the LX1990 and LX1991 sink LED drivers, or boost drivers like the LX1992, LX1993, LX1994, and LX1995.

In each specific application, it is important to recognize the need to correlate the output current of the LX1972 for the target environment and its ambient light conditions. The mechanical mounting of the sensor, light aperture hole size, use of a light pipe or bezel are critical in determining the response of the LX1972 for a given exposure of light.

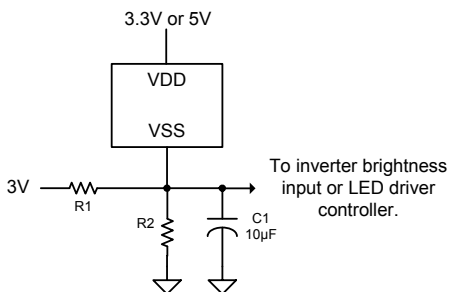
Figure 4

The example in figure 4 shows a fully automatic dimming solution with no user interaction. Choose R1 and R2 values for any desired minimum brightness and slope. Choose C1 to adjust response time to filter 50/60 Hz room lighting. As an example, let's say you wish to generate an output voltage from 0.25V to 1.25V to drive the input of an LED driver controller. The 0.25V represents the minimum LED brightness and 1.25V represents the maximum. The first step would be to determine the ratio of R1 and R2.

$$R1 = R2 \left[\frac{3.0V}{0.25V} - 1 \right] = 11 \times R2$$

Next the value of R2 can be calculated based on the maximum output source current coming from the LX1972 under the application's maximum light exposure, let's say this has been determined to be about 50µA. Thus R2 can be calculated first order as follows:

$$R2 = \left[\frac{1.25V}{50\mu A} \right] = 25K\Omega \therefore R1 = 11 \times R2 = 275K\Omega$$

The output node will actually reach 1.25V when the source current from the LX1972 is only about 44µA since about 6µA of current will be contributed from R1. This assumes a high impedance input to the LED driver. In Figure 5 user adjustable bias control has been added to allow control over the minimum and maximum output voltage. This allows the user to adjust the output brightness to personal preference over a limited range. In addition, an equivalent DC voltage may replace the PWM input source.

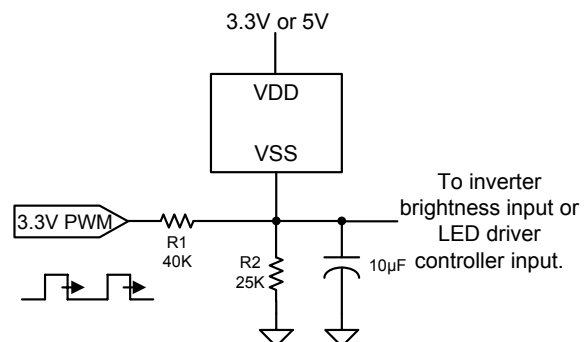
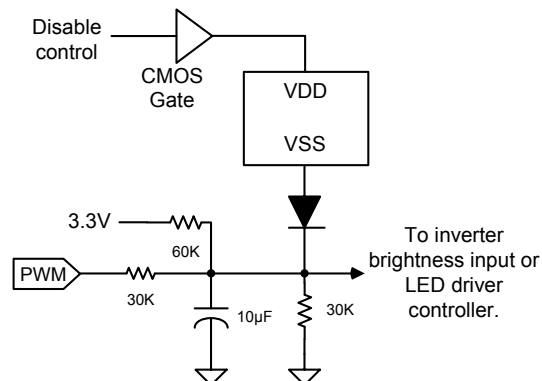
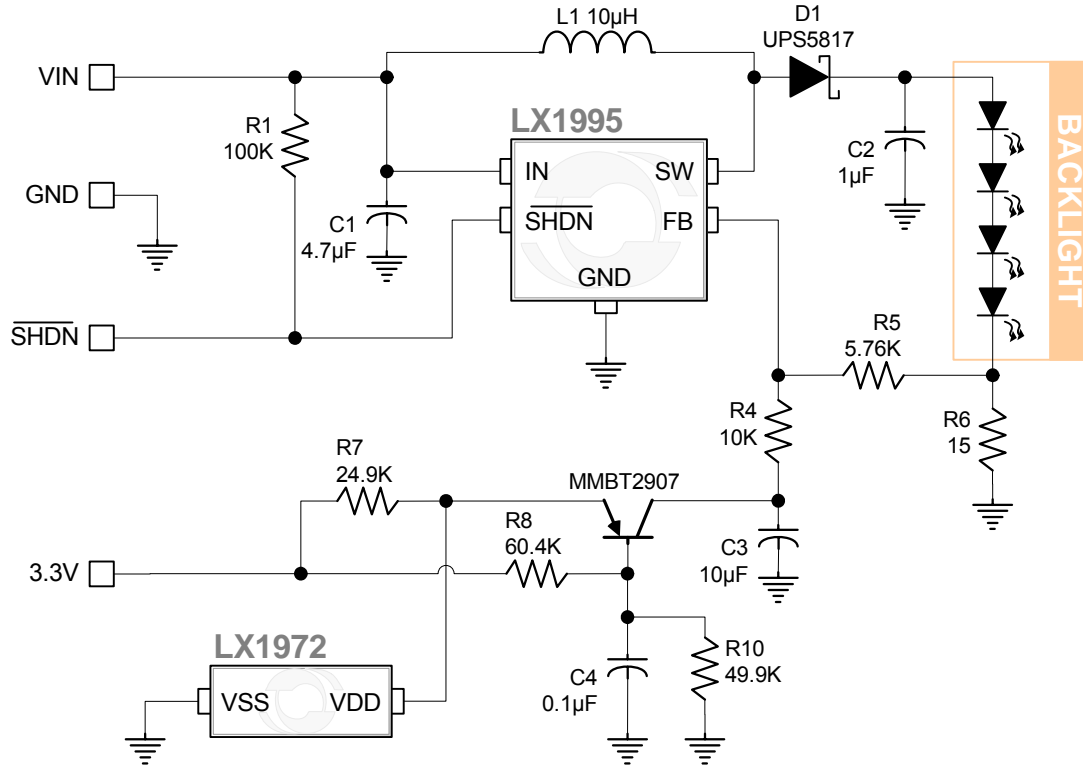
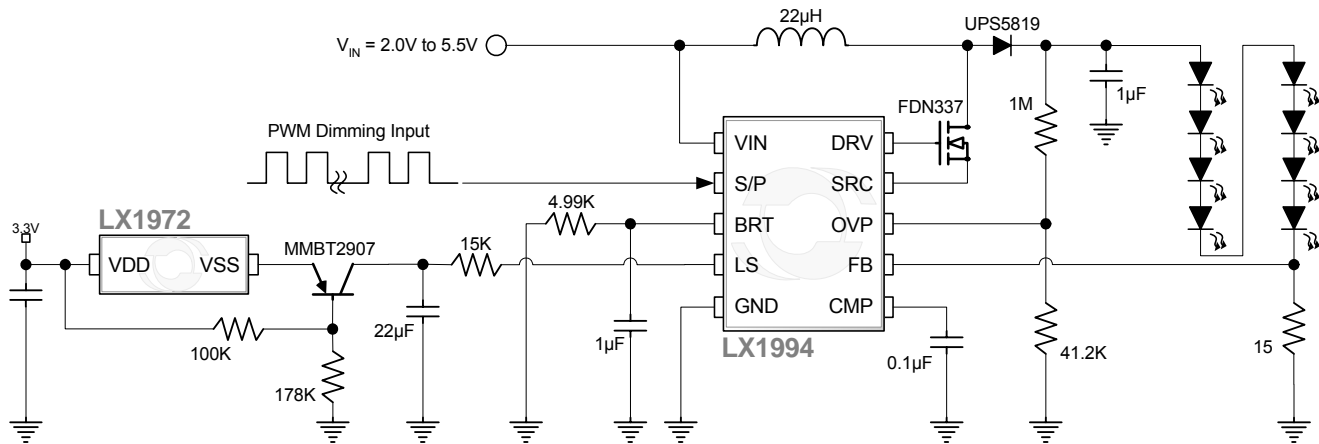
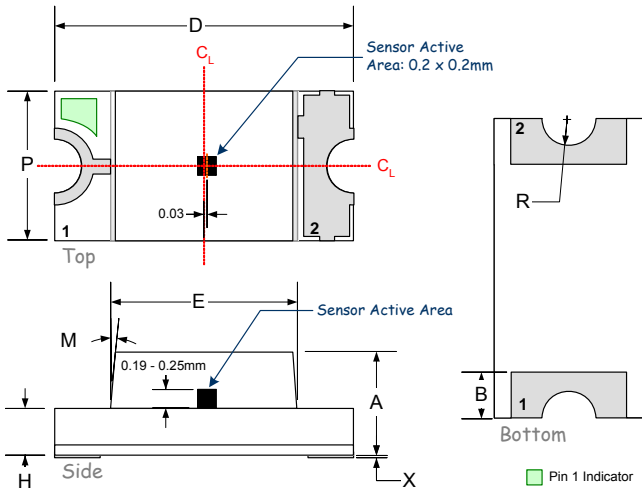

Figure 5

Figure 6 shows how a fully manual override can be quickly added to the example in figure 5. In addition to the gate to turn on and off the LX1972, a diode has been inserted to isolate the sensor when it is disabled.

Figure 6

The preceding examples represent just a few of the potential sensor applications. Further details and additional circuits can be found in the application note (AN-28) LX1970 Visible Light Sensor located in the application section of our website www.microsemi.com. Although this application note is written around our LX1970 visible light sensor the circuits can be easily adapted for use with the LX1972.

APPLICATION CIRCUITS

Figure 7 – Typical Application with Microsemi's LX1995 LED Driver IC

Figure 8 – Typical Application with Microsemi's LX1994 LED driver IC

PACKAGE DIMENSIONS
BC 2-Pin 1206 Standard Carrier

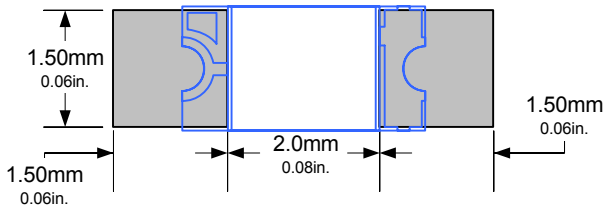
Dim	MILLIMETERS		INCHES	
	MIN	MAX	MIN	MAX
A	0.95	1.25	0.037	0.049
B	0.40	0.70	0.016	0.028
D	3.05	3.35	0.120	0.132
E	1.85	2.15	0.073	0.085
H	0.40	0.60	0.016	0.024
M	3° nom		3° nom	
P	1.45	1.75	0.057	0.069
R	0.25 nom		0.010 nom	
X	0.02	0.05	0.0008	0.002

Note:
Dimensions do not include protrusions; these shall not exceed 0.155mm (.006") on any side.



Recommended Soldering Pattern for reflow soldering of the BC (1206) package.

□ Super Imposed 1206 Package

Basic specification is < 5 seconds @ 260°C when applying solder.

Lead In: 10 min empty
Loaded: 3000 pcs
Lead Out: 40 min empty

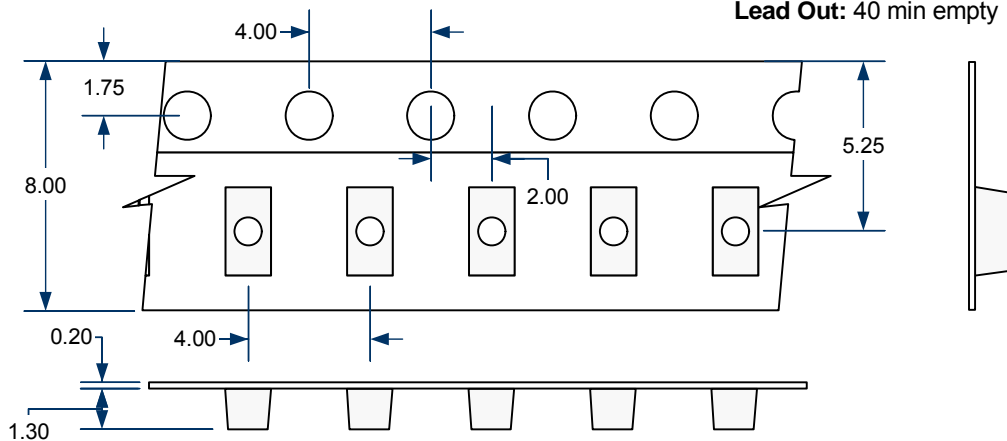



Microsemi[®]

LX1972

Ambient Light Detector

PRODUCTION SPECIFICATION

NOTES

PRODUCTION DATA – Information contained in this document is proprietary to Microsemi and is current as of publication date. This document may not be modified in any way without the express written consent of Microsemi. Product processing does not necessarily include testing of all parameters. Microsemi reserves the right to change the configuration and performance of the product and to discontinue product at any time.