

**DESCRIPTION**

The Microsemi LX8941 is an adjustable, low dropout regulator rated for more than 1A of output current. It can regulate with as low as 0.8V headroom between the input and output voltages, at 1A output current, thus minimizing power dissipation. In addition, it can be used in applications where worst case supplies require a low input / output differential to maintain regulation.

This feature makes it ideal for some processor applications that require 4V operation from a 5V supply. In addition, the LX8941 provides an on / off switch that reduces the IC quiescent current when activated, making it ideal for battery operated applications.

**IMPORTANT:** For the most current data, consult MICROSEMI's website: <http://www.microsemi.com>

**KEY FEATURES**

- 2% Internally Trimmed Output
- Output Current In Excess of 1A
- Input – Output Differential Less Than 0.8V @ 1A
- Reverse Battery Protection
- Short Circuit Protection
- Internal Thermal Overload Protection
- Available in 5-Lead Plastic TO-220 & Surface-Mount TO-263

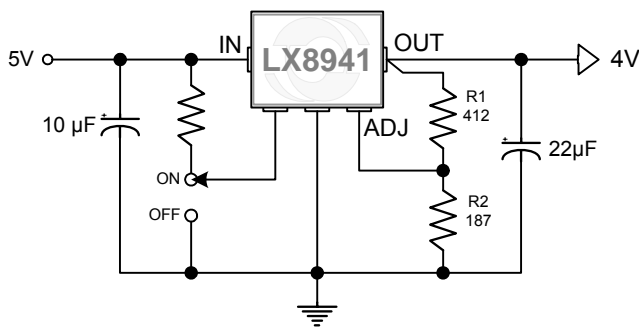
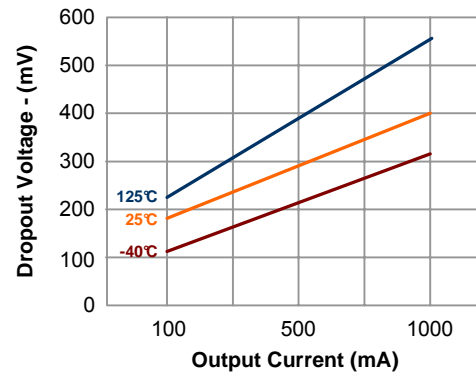
**PRODUCT HIGHLIGHT**

**Dropout Voltage vs. Output Current vs. Temperature**

**PACKAGE ORDER INFO**

T <sub>A</sub> (°C)	<b>P</b>	Plastic TO-220 5 pin	<b>DD</b>	Plastic TO-263 5 Pin
	0 to 70		RoHS Compliant / Pb-free Transition DC: 0543	
		<b>LX8941CP</b>		<b>LX8941CDD</b>

Note: Available in Tape & Reel. Append the letters "TR" to the part number. (i.e. LX8941CDD-TR)

**ABSOLUTE MAXIMUM RATINGS**

Input Voltage ( $V_{IN}$ ).....	26V
Operating Temperature Range.....	150°C
Storage Temperature Range.....	-65°C to 150°C
Lead Temperature (Soldering 10 seconds).....	300°C
Package Peak Temp. for Solder Reflow (40 seconds maximum exposure) ...	260°C (+0 -5)

Note: Exceeding these ratings could cause damage to the device. All voltages are with respect to Ground. Currents are positive into, negative out of specified terminal.

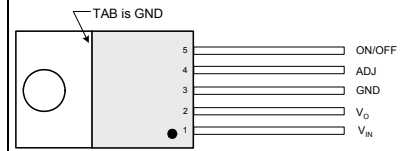
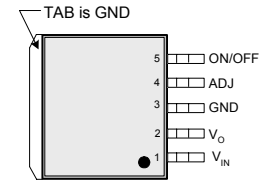
**PACKAGE PIN OUT**

**P PACKAGE**  
(Top View)

**DD PACKAGE**  
(Top View)

RoHS / Pb-free 100% matte Tin Lead Finish

**THERMAL DATA**
**P Plastic TO-220 5-Pin**

THERMAL RESISTANCE-JUNCTION TO TAB, $\theta_{JT}$	<b>4.5°C/W</b>
THERMAL RESISTANCE-JUNCTION TO AMBIENT, $\theta_{JA}$	<b>60°C/W</b>

**DD Plastic TO-263 5-Pin**

THERMAL RESISTANCE-JUNCTION TO CASE, $\theta_{JC}$	<b>4.5°C/W</b>
THERMAL RESISTANCE-JUNCTION TO AMBIENT, $\theta_{JA}$	<b>60°C/W</b>

Junction Temperature Calculation:  $T_J = T_A + (P_D \times \theta_{JA})$ .

The  $\theta_{JA}$  numbers are guidelines for the thermal performance of the device/pc-board system. All of the above assume no ambient airflow.

**RECOMMENDED OPERATING CONDITIONS**

Parameter	Symbol	LX8941			Units
		Min	Typ	Max	
Input Voltage (Note 2)	$V_{IN}$	3.8		26	V
Load Current (with Adequate Heatsinking)		5		1000	mA
Input Capacitor ( $V_{IN}$ to GND)		0.1			$\mu$ F
Output Capacitor with ESR of 10 $\Omega$ max., ( $V_{OUT}$ to GND)		10			$\mu$ F

**ELECTRICAL CHARACTERISTICS**

Unless otherwise specified, the following specifications apply over the operating ambient temperature of 0°C to 125°C for the LX8941CP;  $V_{IN} = 10V$ ,  $I_O = 1A$ ,  $C_{OUT} = 22\mu F$  and are for DC characteristics only. Low duty cycle pulse testing techniques are used which maintain junction and case temperatures equal to the ambient temperature. Note 3: The output voltage range is 4 to 25V and is determined by the two external resistor, R1 and R2. See Product Highlight.

Parameter	Symbol	Test Conditions	LX8941			Units
			Min	Typ	Max	
ADJ Pin Voltage (Note 3)	$V_{ADJ}$	$I_O = 0A$ , $T_A = 25^\circ C$	1.225	1.25	1.275	V
Line Regulation	$\Delta V_{OI}$	$V_O + 2V \leq V_{IN} \leq 26V$ , $I_O = 5mA$		1	50	mV
Load Regulation	$\Delta V_{OL}$	$50mA \leq I_O \leq 1A$ , $V_O = V_{ADJ}$		10	50	mV
Dropout Voltage	$\Delta V$	$I_O = 100mA$		150	300	mV
		$I_O = 500mA$		275	500	mV
		$I_O = 1A$		400	800	mV
Quiescent Current	$I_Q$	$I_O = \leq 5mA$ , $7 \leq V_{IN} \leq 26V$		3	15	mA
		$I_O = 500mA$		30	50	mA
		$I_O = 1000mA$		115	180	mA
Adjust Pin Current	$I_{ADJ}$	$V_{IN} = 10V$ , $I_O = 1A$		2	20	$\mu A$
Current Limit	$I_{CL}$	$V_{IN} = 26V$	1	1.2		A
Output Noise Voltage (Note 4)	$V_{O\ RMS}$	10Hz – 100kHz, $I_O = 5mA$		150		$\mu V_{RMS}$
Long Term Stability (Note 4)				20		mV / 1000hr
Ripple Rejection (Note 4)	$R_R$	$f_O = 120Hz$ , $1V_{RMS}$ , $I_O = 100mA$		66		dB
<b>Enable Logic Section</b>						
On Threshold Voltage			2			V
On Threshold Current				0.1	50	$\mu A$
Off Threshold Voltage					0.8	V
Off Threshold Current			-10	-0.3		$\mu A$

Note 4: These parameters although guaranteed, are not tested in production.

**SIMPLIFIED BLOCK DIAGRAM**

Figure 1 – Simplified Block Diagram

**PACKAGE DIMENSIONS**
**DD 3-Pin Plastic TO-263**

Dim	MILLIMETERS		INCHES	
	MIN	MAX	MIN	MAX
A	10.03	10.67	0.395	0.420
B	8.51	9.17	0.335	0.361
C	4.19	4.59	0.165	0.181
D	1.14	1.40	0.045	0.055
E	0.330	0.51	0.013	0.020
F	1.19	1.34	0.047	0.053
G	2.41	2.66	0.095	0.104
H	2.29	2.79	0.090	0.110
I	—	1.65	—	0.065
J	0	0.25	0	0.010
K	14.60	15.87	0.575	0.625
M	7°		7°	
N	3°		3°	

**P 5-Pin Plastic TO-220**

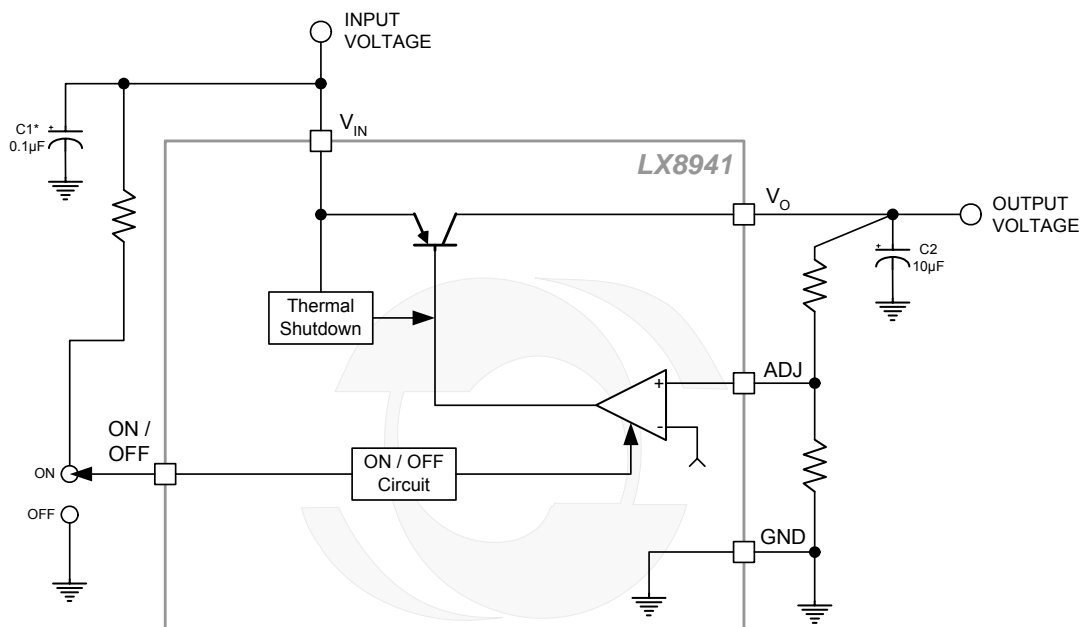
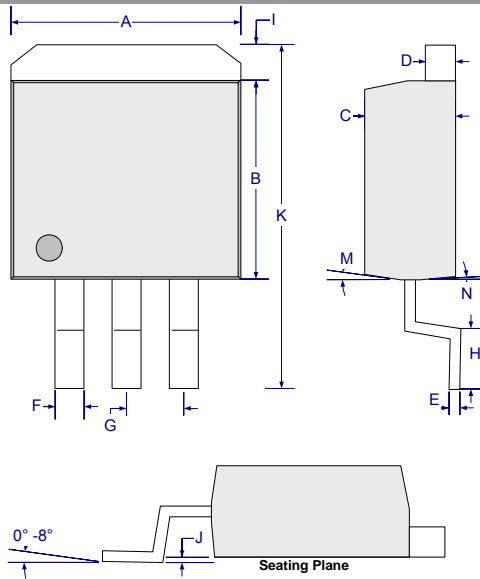
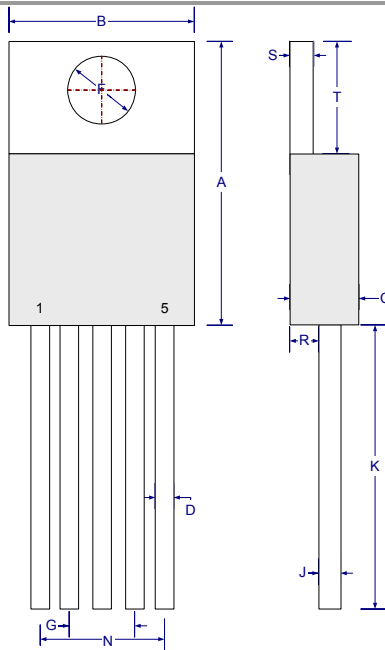
Dim	MILLIMETERS		INCHES	
	MIN	MAX	MIN	MAX
A	14.23	16.51	0.560	0.650
B	9.66	10.66	0.380	0.420
C	3.56	4.82	0.140	0.190
D	0.46	0.89	0.018	0.035
F	3.56	4.06	0.140	0.160
G	3.40		0.134	
J	0.31	1.14	0.012	0.045
K	12.70	14.73	0.500	0.580
N	6.80 TYP		0.268 TYP	
R	2.04	2.92	0.080	0.115
S	1.14	1.39	0.045	0.055
T	5.85	6.85	0.230	0.270

**Note:**

- Dimensions do not include mold flash or protrusions; these shall not exceed 0.155mm(.006") on any side. Lead dimension shall not include solder coverage.



**Microsemi**<sup>®</sup>

**LX8941**

**Adjustable Low Dropout Regulator**

**PRELIMINARY DATA SHEET**

**NOTES**

PRELIMINARY DATA – Information contained in this document is pre-production data and is proprietary to Microsemi. It may not be modified in any way without the express written consent of Microsemi. Product referred to herein is offered in pre-production form only and may not have completed Microsemi's Quality Assurance process for Release to Production. Microsemi reserves the right to change or discontinue this proposed product at any time.