



DESCRIPTION

LX23108AL - is a compact 8 Ports White or RGB back light LED Driver, to be used in large display notebooks, LCD monitors, and TV sets. It is designed to work together with the LX24132 LED Controller as a chipset, driving up to 32 LED strings with a variable current of up to 200mA peak. In addition, the LX23108AL provides the LX24132 LED Controller with its ports voltage samples, that facilitate the control of the LED strings supply voltage through an external DC/DC converter; minimizing the power dissipation while regulating the LED currents for all 8 strings. Current regulation is maintained within a ± 3 percent.

The LX23108AL LED Driver includes 8 High Bandwidth Current Limiter Cells with PWM Control (ON/OFF Signal).

The chip is designed to operate with external Sense Resistors. Such configuration provides maximum flexibility for system designers when scaling up or down the LED currents for meeting a wide range of high accuracy application requirements.

IMPORTANT: For the most current data, consult MICROSEMI's website: <http://www.microsemi.com>

The LX23108AL LED Driver enables a wide dimming range, achieved through a combination of LED current amplitude and PWM duty-cycle control. In addition, the chipset provides a thermally robust solution through advanced system control; including Drain Voltage Sensing for Open/Shorts events and per string Thermal Protection monitoring.

The LX23108AL LED Driver is housed in a 32 pin, 5mmx5mm QFN package.

KEY FEATURES

- White LED, or RGB Backlight Driver for large size display panels
- Up to 8 LED strings with $\pm 0.5\%$ precision current matching.
- Wide dimming ratio with PWM duty-cycle and LED current amplitude controls.
- 12 bit PWM duty-cycle resolution – controlled by LX24132 LED Controller.
- 8 bit resolution for LED current setting – controlled by LX24132 LED Controller.
- Open string, short LED and Over-Temperature protection per individual channel.

APPLICATIONS

- LCD Monitor and TV
- Large Signage Display

PACKAGE ORDER INFO

THERMAL DATA

T_A (°C)	<i>MLPQ Plastic 5 x5mm 32 pin</i>	27.5 ° C/W According to the JESD51-7
	RoHS Compliant / Pb-free / MSL 1	THERMAL RESISTANCE-JUNCTION TO AMBIENT
-40 to 85	LX23108ALILQ	Junction Temperature Calculation: $T_J = T_A + (P_D \times \theta_{JA})$.
Note: Available in Tape & Reel. Append the letters "TR" to the part number. (i.e. LX23108ALILQ-TR)		The θ_{JA} numbers are guidelines for the thermal performance of the device/pc-board system. All of the above assume no ambient airflow.



LX23108AL

8 Ports LED Back Light High Voltage Driver

DATA SHEET

ABSOLUTE MAXIMUM RATINGS

V _{CC} Supply Input Voltage	-0.5V to 5.5V
V _{IO} Supply Input Voltage	-0.5V to 4.5V
LED Pins	-0.3V to 70V
All other pins	-0.5V to V _{IO} +0.3 up to 4.5V
Operating Ambient Temperature Range	-40 to 85°C
Maximum Operating Junction Temperature	150°C
ESD Protection at all I/O pins	+/- 2KV HBM
Storage Temperature Range	-65°C to 150°C
Package Peak Temperature for Solder Reflow (40 seconds maximum exposure)	260°C(+0,-5)

Notes: Exceeding these ratings could cause damage to the device. All voltages are with respect to Ground. Currents are positive into, negative out of specified terminal.

PACKAGE PIN OUT

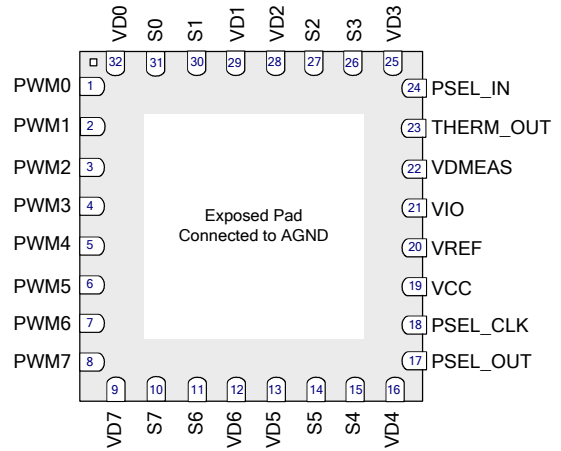

(Top View)

RoHS / Pb-free Matte Tin Finish / MSL 1

© 2010 Microsemi Corp.
All rights reserved.

For support contact: sales_AMSG@microsemi.com
Visit our web site at: www.microsemi.com