

**TARGET SPECIFICATION**
**DESCRIPTION**

The NX9548 is buck switching converter in multi chip module designed for step down DC to DC converter in portable applications. It is optimized to convert single supply up to 20V bus voltage to as low as 0.75V output voltage. The output current can be up to 7A. It can be selected to operate in synchronous mode or non synchronous mode to improve the efficiency at light load.

Constant on time control provides fast response, good line regulation and nearly constant frequency under wide voltage input range.

Over current protection and FB UVLO followed by latch feature.

Other features includes: internal boost schottky diode, 5V gate drive capability, power good indicator, over current protection, over voltage protection and adaptive dead band control.

NX9548 is available in 5x5 MCM package.

**KEY FEATURES**

- Internal Boost Schottky Diode
- Ultrasonic Mode Operation Available
- Bus Voltage Operation From 4.5V to 20V
- Less than 1uA Shutdown Current with Enable Low
- Excellent Dynamic Response with Constant On Time Control
- Selectable Between Synchronous CCM Mode and Diode Emulation Mode to Improve Efficiency at Light Load
- Programmable Switching Frequency
- Current Limit and FB UVLO with Latch Off
- Over Voltage Protection with Latch Off

**APPLICATIONS**

- UMPC, Notebook PCs and Desktotes
- Tablet PCs/Slates
- On Board DC to DC Such as 12V to 3.3V, 2.5V or 1.8V
- Hand-held Portable Instruments

**IMPORTANT:** For the most current data, consult MICROSEMI's website: <http://www.microsemi.com>

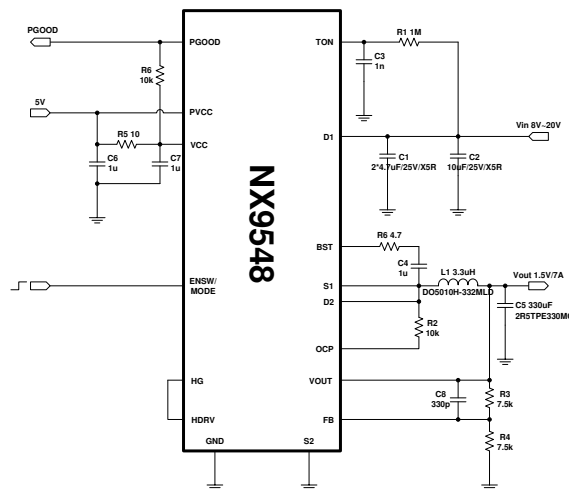
**PRODUCT HIGHLIGHT**

**PACKAGE ORDER INFO**
**THERMAL DATA**

|   |           |                           |  |
|---|-----------|---------------------------|--|
| $T_A$ (°C)  | <b>LD</b> | <b>MCM-32L (5 x 5 mm)</b> | $\theta_{JA} = 75$ °C/W  |
|   |           | RoHS Compliant / Pb-free  | THERMAL RESISTANCE-JUNCTION TO AMBIENT   |
| 0 to +70  |           | <b>NX9548CMTR</b>         | Junction Temperature Calculation: $T_J = T_A + (P_D \times \theta_{JA})$ .<br>The $\theta_{JA}$ numbers are guidelines for the thermal performance of the device/pc-board system. All of the above assume no ambient airflow.<br>$\theta_{JA}$ number above is with 4-layer PCB board. |
| Note: Available in Tape & Reel. Append the letters "TR" to the part number. |           |                           |  |



#### TARGET SPECIFICATION

#### ABSOLUTE MAXIMUM RATINGS

|  |                           |
|--|---------------------------|
| VCC, PVCC, TON.....                          | -0.3V to 6.5V             |
| BST, HDRV to SW.....                         | -0.3V to 6.5V             |
| D1 to S1 and D2 to S2 .....                  | 30V                       |
| All other pins .....                         | -0.3V to VCC+0.3V or 6.5V |
| Maximum Operating Junction Temperature ..... | -40°C to 150°C            |
| Storage Temperature Range.....               | -65°C to 150°C            |
| ESD Susceptibility .....                     | 2kV                       |
| Power Dissipation.....                       | TBD                       |
| Output Current .....                         | TBD                       |

Notes: Exceeding these ratings could cause damage to the device. All voltages are with respect to GND. Currents are positive into, negative out of specified terminal.

#### PACKAGE PIN OUT

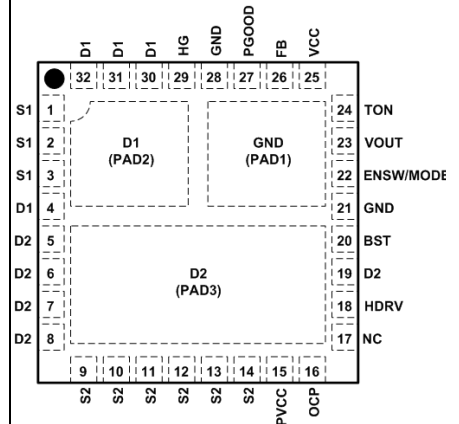

**MCM PACKAGE**  
XXXX= DATE/LOT CODE

(Top View)  
RoHS / Pb-free 100% Matte Tin Lead Finish

#### ELECTRICAL CHARACTERISTICS

Unless otherwise specified, the following specifications apply over the operating ambient temperature of  $0^{\circ}\text{C} \leq T_A \leq 85^{\circ}\text{C}$  except where otherwise noted with the following test conditions: VCC = PVIN = 5V. Typical parameter refers to  $T_J=25^{\circ}\text{C}$

| Parameters                      | Symbol   | Test Conditions/Comments       | Min | Typ | Max | Units |
|---------------------------------|----------|--------------------------------|-----|-----|-----|-------|
| <b>VIN</b>                      |          |                                |     |     |     |       |
| Recommended Voltage Range       |          |                                | 4.5 |     | 20  | V     |
| Shut Down Current               |          | ENSW=GND                       |     | 1   |     | uA    |
| <b>VCC, PVCC SUPPLY</b>         |          |                                |     |     |     |       |
| Input Voltage Range             | Vin      |                                | 4.5 |     | 5.5 | V     |
| Operating Quiescent Current     |          | FB=0.85V, ENSW=5V              |     | 1.8 |     | mA    |
| Shut Down Current               |          | ENSW=GND                       |     | 1   |     | uA    |
| <b>VCC UVLO</b>                 |          |                                |     |     |     |       |
| Under Voltage Lockout Threshold | Vcc_UVLO |                                | 3.9 | 4.1 | 4.5 | V     |
| Falling VCC Threshold           |          |                                | 3.7 | 3.9 | 4.3 | V     |
| <b>ON and OFF TIME</b>          |          |                                |     |     |     |       |
| TON Operating Current           |          | VIN=15V, Rton=1MOhm            |     | 15  |     | uA    |
| On - Time                       |          | VIN=9V, VOUT=0.75V, Rton=1MOhm | 312 | 390 | 468 | ns    |
| Minimum Off Time                |          |                                | 380 | 590 | 800 | ns    |



#### TARGET SPECIFICATION

#### ELECTRICAL CHARACTERISTICS

Unless otherwise specified, the following specifications apply over the operating ambient temperature of  $0^{\circ}\text{C} \leq T_A \leq 85^{\circ}\text{C}$  except where otherwise noted with the following test conditions:  $V_{CC} = PV_{IN} = 5V$ . Typical parameter refers to  $T_J = 25^{\circ}\text{C}$

| Parameters                                  | Symbol | Test Conditions/Comments            | Min     | Typ  | Max       | Units |
|---|--------|-------------------------------------|---------|------|-----------|-------|
| <b>FB VOLTAGE</b>                           |        |                                     |         |      |           |       |
| Internal Feedback Voltage                   | Vref   |                                     | 0.739   | 0.75 | 0.761     | V     |
| Input Bias Current                          |        |                                     |         |      | 200       | nA    |
| Line Regulation                             |        | VCC from 4.5V to 5.5V               | -1      |      | 1         | %     |
| <b>OUT VOLTAGE</b>                          |        |                                     |         |      |           |       |
| Output Range                                |        |                                     | 0.75    |      | 3.3       | V     |
| VOU Shut Down Discharge Resistance          |        | ENSW/MODE=GND                       |         | 30   |           | Ohm   |
| Soft Start Time                             |        |                                     |         | 1.5  |           | ms    |
| <b>PGOOD</b>                                |        |                                     |         |      |           |       |
| PGOOD High Rising Threshold                 |        |                                     |         | 90   |           | %Vref |
| PGOOD Delay After Soft Start                |        | Note 1                              |         | 1.6  |           | ms    |
| PGOOD Propagation Delay Filter              |        | Note 1                              |         | 2    |           | us    |
| PGOOD Hysteresis                            |        |                                     |         | 5    |           | %     |
| PGOOD Output Switch Impedance               |        |                                     |         | 13   |           | Ohm   |
| PGOOD Leakage Current                       |        |                                     |         | 1    |           | uA    |
| <b>ENSW/MODE THRESHOLD and BIAS CURRENT</b> |        |                                     |         |      |           |       |
| PFM/Non Synchronous Mode                    |        |                                     | 80% VCC |      | VCC+ 0.3V | V     |
| Ultrasonic Mode                             |        |                                     | 60% VCC |      | 80% VCC   | V     |
| Synchronous Mode                            |        | Leave it open or use limits in spec | 2       |      | 60% VCC   | V     |
| Shutdown Mode                               |        |                                     | 0       |      | 0.8       | V     |
| Input Bias Current                          |        | ENSW/MODE=VCC                       |         | 5    |           | uA    |
|   |        | ENSW/MODE=GND                       |         | -5   |           | uA    |
| <b>SW ZERO CROSS COMPARATOR</b>             |        |                                     |         |      |           |       |
| Offset Voltage                              |        |                                     |         | 5    |           | mV    |
| <b>CURRENT LIMIT</b>                        |        |                                     |         |      |           |       |
| Ocset Setting Current                       |        |                                     | 20      | 24   | 28        | uA    |
| <b>OVER TEMPERATURE</b>                     |        |                                     |         |      |           |       |
| Threshold                                   |        | Note 1                              |         | 155  |           | °C    |



#### TARGET SPECIFICATION

#### ELECTRICAL CHARACTERISTICS

Unless otherwise specified, the following specifications apply over the operating ambient temperature of  $0^{\circ}\text{C} \leq T_A \leq 85^{\circ}\text{C}$  except where otherwise noted with the following test conditions:  $V_{CC} = V_{VIN} = 5\text{V}$ . Typical parameter refers to  $T_J = 25^{\circ}\text{C}$

| Parameters | Symbol | Test Conditions/Comments | Min | Typ | Max | Units              |
|------------|--------|--------------------------|-----|-----|-----|--------------------|
| Hysteresis |        | Note 1                   |     | 15  |     | $^{\circ}\text{C}$ |

#### UNDER VOLTAGE

|              |  |  |  |    |  |       |
|--------------|--|--|--|----|--|-------|
| FB Threshold |  |  |  | 70 |  | %Vref |
|--------------|--|--|--|----|--|-------|

#### OVER VOLTAGE

|                          |  |  |  |     |  |       |
|--------------------------|--|--|--|-----|--|-------|
| Over Voltage Tripp Point |  |  |  | 125 |  | %Vref |
|--------------------------|--|--|--|-----|--|-------|

#### INTERNAL SCHOTTKY DIODE

|                      |  |                      |  |     |  |    |
|----------------------|--|----------------------|--|-----|--|----|
| Forward Voltage Drop |  | Forward current=50mA |  | 500 |  | mV |
|----------------------|--|----------------------|--|-----|--|----|

#### OUTPUT STAGE

|                             |  |  |  |    |  |      |
|-----------------------------|--|--|--|----|--|------|
| High Side MOSFET $R_{DSON}$ |  |  |  | 20 |  | mOhm |
| Low Side MOSFET $R_{DSON}$  |  |  |  | 17 |  | mOhm |
| Output Current              |  |  |  | 7  |  | A    |

Note1: This parameter is guaranteed by design but not tested in production(GBNT).

#### FUNCTIONAL PIN DESCRIPTION

| Name | Pin #            | Description  |
|------|------------------|--|
| S1   | 1-3              | Source of high side MOSFET. These pins must be connected directly to the drain of low side MOSFET via a plane connection.  |
| D1   | 4, 30-32<br>PAD2 | Drain of high side MOSFET.   |
| D2   | 5-8, 19,<br>PAD3 | Drain of low side MOSFET and the controller pin out SW.  |
| S2   | 9-14             | Source of low side MOSFET and need to be directly connected to power ground via multiple vias.   |
| PVCC | 15               | This pin provides the voltage supply to the lower MOSFET drivers. Place a high frequency decoupling capacitor 1uF X5R from this pin to GND.  |
| OCP  | 16               | This pin is connected to the drain of the external low side MOSFET via resistor and is the input of the over current protection(OCP) comparator. An internal current source is flown from this pin to the external resistor which sets the OCP voltage across the Rdson of the low side MOSFET. Current limit point is this voltage divided by the Rdson. Once this threshold is reached the chip is latched out |
| NC   | 17               | Not used.  |



#### TARGET SPECIFICATION

|           |              |   |
|-----------|--------------|---|
| HDRV      | 18           | High side gate driver output which needs to be connected to high side MOSFET gate HG pin. A small value resistor may be placed between two pins to slow down the high side MOSFET, reducing the ringing on SW nodes.                                |
| BST       | 20           | This pin supplies voltage to high side FET driver. A minimum high freq 0.47uF ceramic capacitor is placed as close as possible to and connected to this pin and respected pin 19. A 4.7Ohm resistor is recommended in series with this capacitor.   |
| ENSW/MODE | 22           | Switching converter enable input. Connect to VCC for PFM/Non synchronous mode, connected to an external resistor divider equals to 70%VCC for ultrasonic, connected to GND for shutdown mode, floating or connected to 2V for the synchronous mode. |
| VOUT      | 23           | This pin is directly connected to the output of the switching regulator and senses the VOUT voltage. An internal MOSFET discharges the output during turn off.  |
| TON       | 24           | VIN sensing input. A resistor connects from this pin to VIN will set the frequency. A 1nF capacitor from this pin to GND is recommended to ensure the proper operation.   |
| VCC       | 25           | This pin supplies the internal 5V bias circuit. A 1uF X7R ceramic capacitor is placed as close as possible to this pin and ground pin.  |
| FB        | 26           | This pin is the error amplifiers inverting input. This pin is connected via resistor divider to the output of the switching regulator to set the output DC voltage from 0.75V to 3.3V.  |
| PGOOD     | 27           | PGOOD indicator for switching regulator. It requires a pull up resistor to VCC or lower voltage. When FB pin reaches 90% of the reference voltage PGOOD transitions from LO to HI state.  |
| GND       | 21, 28, PAD1 | Ground pin.   |
| HG        | 29           | High side MOSFET gate.  |



#### TARGET SPECIFICATION

#### FUNCTIONAL BLOCK DIAGRAM

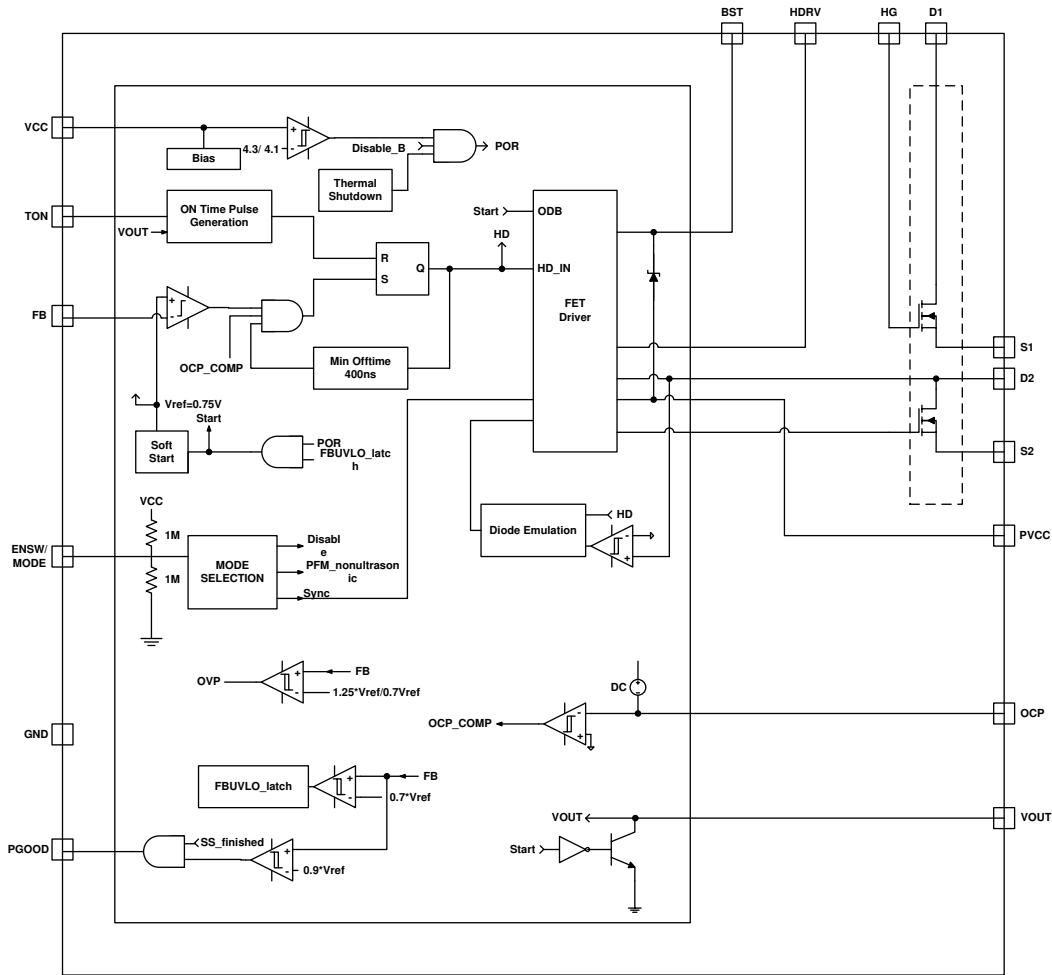

Figure 1. Functional Block Diagram.

**APPLICATION INFORMATION (OPERATION THEORY)**
**Symbol Used In Application Information:**

|                      |                           |
|----------------------|---------------------------|
| V <sub>IN</sub>      | - Input voltage           |
| V <sub>OUT</sub>     | - Output voltage          |
| I <sub>OUT</sub>     | - Output current          |
| ΔV <sub>RIPPLE</sub> | - Output voltage ripple   |
| FS                   | - Working frequency       |
| ΔI <sub>RIPPLE</sub> | - Inductor current ripple |

**Design Example**

The following is typical application for NX9548, the schematic is figure 1.

V<sub>IN</sub> = 8 to 20V

V<sub>OUT</sub> = 1.5V

FS = 220kHz

I<sub>OUT</sub> = 7A

ΔV<sub>RIPPLE</sub> ≤ 60mV

ΔV<sub>DROOP</sub> ≤ 60mV @ 3A step

**On Time and Frequency Calculation**

The constant on time control technique used in NX9548 delivers high efficiency, excellent transient dynamic response, make it a good candidate for step down notebook applications.

An internal one shot timer turns on the high side driver with an on time which is proportional to the input supply V<sub>IN</sub> as well inversely proportional to the output voltage V<sub>OUT</sub>. During this time, the output inductor charges the output cap increasing the output voltage by the amount equal to the output ripple. Once the timer turns off, the Hdrv turns off and cause the output voltage to decrease until reaching the internal FB voltage of 0.75V on the PFM comparator. At this point the comparator trips causing the cycle to repeat itself. A minimum off time of 400nS is internally set.

The equation setting the On Time is as follows:

$$T_{ON} = \frac{4.45 \times 10^{-2} \times R_{TON} \times V_{OUT}}{V_{IN} - 0.5V} \quad \dots (1)$$

$$FS = \frac{V_{OUT}}{V_{IN} \times T_{ON}} \quad \dots (2)$$

In this application example, the R<sub>TON</sub> is chosen to be 1Mohm, when V<sub>IN</sub>=20V, the T<sub>ON</sub> is 310nS and FS is around 220kHz.

**Output Inductor Selection**

The value of inductor is decided by inductor ripple current and working frequency. Larger inductor value normally means smaller ripple current. However if the inductance is chosen too large, it brings slow response and lower efficiency. The ripple current is a design freedom which can be decided by design engineer according to various application requirements. The inductor value can be calculated by using the following equations:

$$L_{OUT} = \frac{(V_{IN} - V_{OUT}) \times T_{ON}}{I_{RIPPLE}} \quad \dots (3)$$

$$I_{RIPPLE} = k \times I_{OUT}$$

where k is percentage of output current.

In this example, inductor from COILCRAFT DO5010H-332 with L=3.3uH is chosen.

Current Ripple is recalculated as below:

$$I_{RIPPLE} = \frac{(V_{IN} - V_{OUT}) \times T_{ON}}{L_{OUT}} \quad \dots (4)$$

$$= \frac{(20V - 1.5V) \times 310nS}{3.3uH}$$

$$= 1.738A$$

**Output Capacitor Selection**

Output capacitor is basically decided by the amount of the output voltage ripple allowed during steady state(DC) load condition as well as specification for the load transient. The optimum design may require a couple of iterations to satisfy both conditions.

**Based on DC Load Condition**

The amount of voltage ripple during the DC load condition is determined by equation(5).

$$\Delta V_{RIPPLE} = ESR \times \Delta I_{RIPPLE} + \frac{\Delta I_{RIPPLE}}{8 \times FS \times C_{OUT}} \quad \dots (5)$$

Where ESR is the output capacitors' equivalent series resistance, C<sub>OUT</sub> is the value of output capacitors.



#### TARGET SPECIFICATION

Typically POSCAP is recommended to use in NX9548's wapplications. The amount of the output voltage ripple is dominated by the first term in equation(5) and the second term can be neglected.

For this example, one POSCAP 2R5TPE330MC is chosen as output capacitor, the ESR and inductor current typically determines the output voltage ripple. When VIN reach maximum voltage, the output voltage ripple is in the worst case.

$$ESR_{desire} = \frac{\Delta V_{RIPPLE}}{\Delta I_{RIPPLE}} = \frac{30mV}{1.738A} = 17.2m\Omega \quad \dots (6)$$

If low ESR is required, for most applications, multiple capacitors in parallel are needed. The number of output capacitor can be calculate as the following:

$$N = \frac{ESR_E \times \Delta I_{RIPPLE}}{\Delta V_{RIPPLE}} \quad \dots (7)$$

$$N = \frac{12m\Omega \times 1.738A}{30mV}$$

N=0.70

The number of capacitor has to be round up to a integer. Choose N =1.

#### Based On Transient Requirement

Typically, the output voltage droop during transient is specified as

$$\Delta V_{droop} < \Delta V_{tran}@step \text{ load } \Delta I_{STEP}$$

During the transient, the voltage droop during the transient is composed of two sections. One section is dependent on the ESR of capacitor, the other section is a function of the inductor, output capacitance as well as input, output voltage. For example, for the overshoot when load from high load to light load with a DISTEP transient load, if assuming the bandwidth of system is high enough, the overshoot can be estimated as the following equation.

$$\Delta V_{overshoot} = ESR \times \Delta I_{step} + \frac{V_{OUT}}{2 \times L \times C_{OUT}} \times \tau^2 \quad \dots (8)$$

Where  $\tau$  is a function of capacitor, etc.

$$\tau = \begin{cases} 0 & \text{if } L \leq L_{crit} \\ \frac{L \times \Delta I_{step}}{V_{OUT}} - ESR \times C_{OUT} & \text{if } L \geq L_{crit} \end{cases} \quad \dots (9)$$

Where

$$L_{crit} = \frac{ESR \times C_{OUT} \times V_{OUT}}{\Delta I_{step}} = \frac{ESR_E \times C_E \times V_{OUT}}{\Delta I_{step}} \quad \dots (10)$$

where ESRE and CE represents ESR and capacitance of each capacitor if multiple capacitors are used in parallel.

The above equation shows that if the selected output inductor is smaller than the critical inductance, the voltage droop or overshoot is only dependent on the ESR of output capacitor. For low frequency capacitor such as electrolytic capacitor, the product of ESR and capacitance is high and crit L  $\neq$  L is true. In that case, the transient spec is mostly like to dependent on the ESR of capacitor.

Most case, the output capacitor is multiple capacitor in parallel. The number of capacitor can be calculated by the following

$$N = \frac{ESR_E \times \Delta I_{step}}{\Delta V_{tran}} + \frac{V_{OUT}}{2 \times L \times C_E \times \Delta V_{tran}} \times \tau^2 \quad \dots (11)$$

Where

$$\tau = \begin{cases} 0 & \text{if } L \leq L_{crit} \\ \frac{L \times \Delta I_{step}}{V_{OUT}} - ESR_E \times C_E & \text{if } L \geq L_{crit} \end{cases} \quad \dots (12)$$

For example, assume voltage droop during transient is 60mV for 3A load step.

If one POSCAP 2R5TPE330MC(330uF, 12mohm ESR) is used, the crtical inductance is given as

$$\begin{aligned} I_{crit} &= \frac{ESR_E \times C_E \times V_{OUT}}{\Delta I_{step}} \\ &= \frac{12m\Omega \times 3300\mu F \times 1.8V}{3A} \\ &= 23.76\mu H \end{aligned}$$

The selected inductor is 3.3uH which is smaller than critical inductance. In that case, the output voltage transient mainly dependent on the ESR.

number of capacitor is

$$N = \frac{ESR_E \times \Delta I_{step}}{\Delta V_{tran}} = \frac{12m\Omega \times 4.5A}{60mV} = 0.9$$

Choose N=1.



#### TARGET SPECIFICATION

#### Based On Stability Requirement

ESR of the output capacitor can not be chosen too low which will cause system unstable. The zero caused by output capacitor's ESR must satisfy the requirement as below:

$$F_{ESR} = \frac{1}{2 \times \pi \times ESR \times C_{OUT}} \leq \frac{F_{SW}}{4} \quad \dots (13)$$

Besides that, ESR has to be bigger enough so that the output voltage ripple can provide enough voltage ramp to error amplifier through FB pin. If ESR is too small, the error amplifier can not correctly detect the ramp, high side MOSFET will be only turned off for minimum time 400nS. Double pulsing and bigger output ripple will be observed. In summary, the ESR of output capacitor has to be big enough to make the system stable, but also has to be small enough to satisfy the transient and DC ripple requirements.

#### Input Capacitor Selection

Input capacitors are usually a mix of high frequency ceramic capacitors and bulk capacitors. Ceramic capacitors bypass the high frequency noise, and bulk capacitors supply switching current to the MOSFETs. Usually 1uF ceramic capacitor is chosen to decouple the high frequency noise. The bulk input capacitors are decided by voltage rating and RMS current rating. The RMS current in the input capacitors can be calculated as:

$$I_{RMS} = I_{OUT} \times \sqrt{D} \times \sqrt{1 - D} \quad \dots (14)$$

$$D = T_{ON} \times F_S$$

When VIN = 22V, VOUT=1.5V, IOUT=9A, the result of input RMS current is 2.3A.

For higher efficiency, low ESR capacitors are recommended. One 10uF/X5R/25V and two 4.7uF/X5R /25V ceramic capacitors are chosen as input capacitors.

#### Output Voltage Calculation

Output voltage is set by reference voltage and external voltage divider. The reference voltage is fixed at 0.75V. The divider consists of two ratioed resistors so that the output voltage applied at the Fb pin is 0.75V when the output voltage is at the desired value.

The following equation applies to figure 12, which shows the relationship between OUT V , REF V and voltage divider.

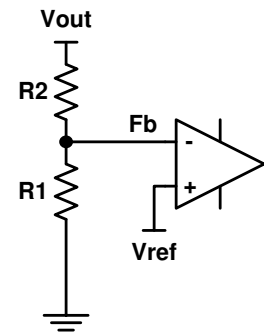

Figure 2- Voltage Divider

$$R_1 = \frac{R_2 \times V_{REF}}{V_{OUT} - V_{REF}} \quad \dots (14)$$

where R2 is part of the compensator, and the value of R1 value can be set by voltage divider.

#### Mode Selection

NX9548 can be operated in PFM mode, ultrasonic PFM mode, CCM mode and shutdown mode by applying different voltage on ENSW/MODE pin.

When VCC applied to ENSW/MODE pin, NX9548 is In PFM mode. The low side MOSFET emulates the function of diode when discontinuous continuous mode happens, often in light load condition. During that time, the inductor current crosses the zero ampere border and becomes negative current. When the inductor current reaches negative territory, the low side MOSFET is turned off and it takes longer time for the output voltage to drop, the high side MOSFET waits longer to be turned on. At the same time, no matter light load and heavy load, the on time of high side MOSFET keeps the same. Therefore the lightier load, the lower the switching frequency will be. In utrosonic PFM mode, the lowest frequency is set to be 25kHz to avoid audio frequency modulation. This kind of reduction of frequency keeps the system running at light light with high efficiency.

In CCM mode, inductor current zero-crossing sensing is disabled, low side MOSFET keeps on even when inductor current becomes negative. In this way the efficiency is lower compared with PFM mode at light load, but frequency will be kept constant.

**TARGET SPECIFICATION**

### Over Current Protection

Over current protection for NX9548 is achieved by sensing current through the low side MOSFET. An typical internal current source of 24uA flows through an external resistor connected from OCSET pin to SW node sets the over current protection threshold. When synchronous FET is on, the voltage at node SW is given as

$$V_{SW} = -I_L \times R_{DSON}$$

The voltage at pin OCSET is given as

$$I_{OCP} \times R_{OCP} + V_{SW}$$

When the voltage is below zero, the over current occurs as shown in figure below.

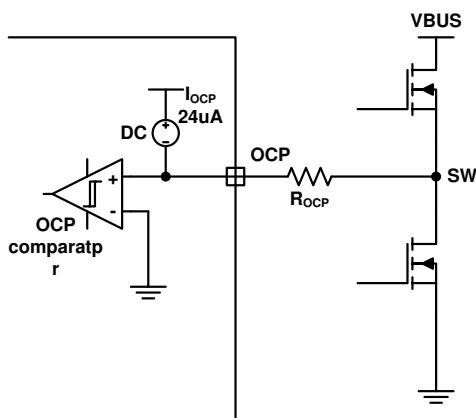

Figure 3 – Over Voltage Protection

The over current limit can be set by the following equation.

$$I_{SET} = I_{OCP} \times \frac{R_{OCP}}{R_{DSON}}$$

The low side MOSFET RDSON is 24mW at the OCP occurring moment, and the current limit is set at 10A, then

$$R_{OCP} = \frac{I_{SET} \times R_{DSON}}{I_{OCP}} = \frac{10A \times 24m\Omega}{24\mu A} = 10k\Omega$$

Choose  $R_{OCP} = 10k\Omega$ .

### Power Good Output

Power good output is open drain output, a pull up resistor is needed. Typically when softstart is finished and FB pin voltage is over 90% of  $V_{REF}$ , the PGOOD pin is pulled to high after a 1.6ms delay.

### Over Output Voltage Protection

Typically when the FB pin voltage is over 125% of  $V_{REF}$ , the high side MOSFET will be turned off and the low side MOSFET will be latched to be on to discharge the output voltage. To resume the switching operation, reset VCC or EN is necessary.

### Under Output Voltage Protection

Typically when the FB pin voltage is under 70% of  $V_{REF}$ , the high side and low side MOSFET will be turned off. To resume the switching operation, VCC or ENSW has to be reset.



#### TARGET SPECIFICATION

#### TYPICAL APPLICATION

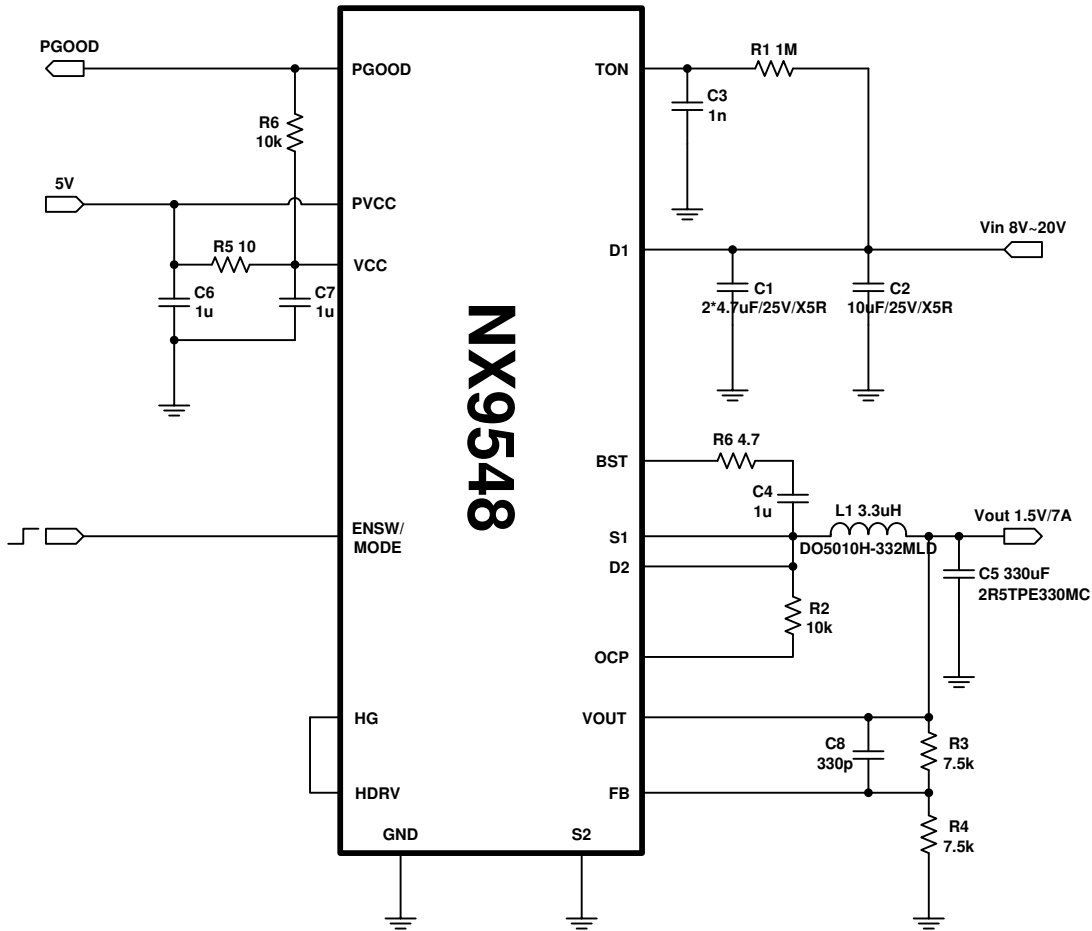

Figure 4. NX9548 Typical Application



#### TARGET SPECIFICATION

#### STEP RESPONSE

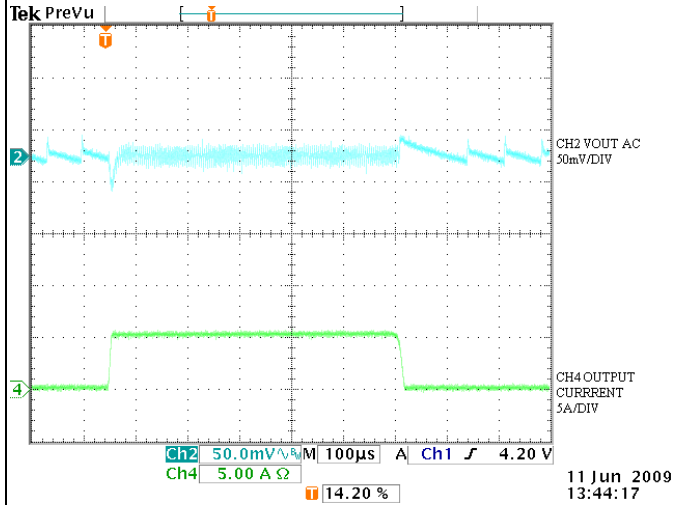

Figure 5. Step response in PFM mode when  $V_{IN}=5V$

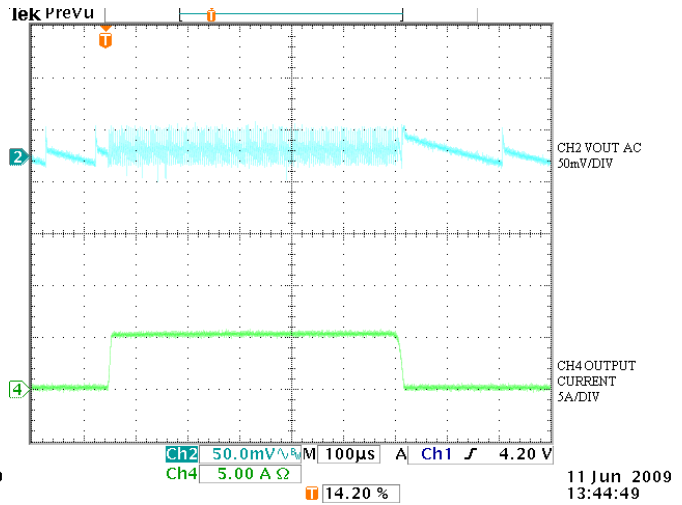

Figure 6. Step response in PFM mode when  $V_{IN}=20V$

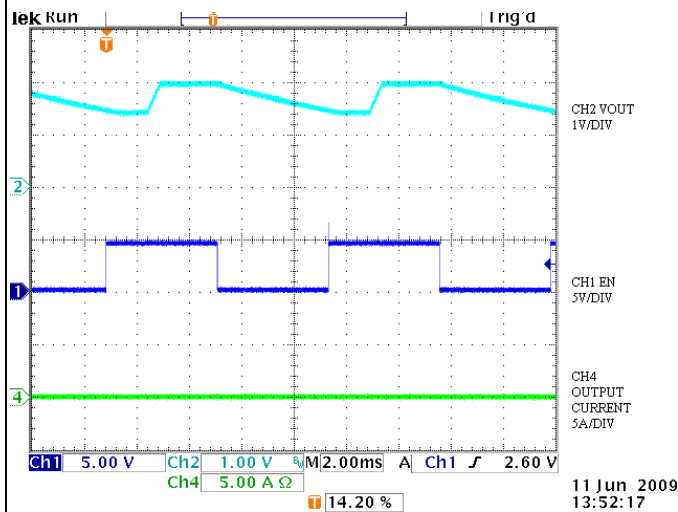

Figure 7. Start up and Shut down, No Load

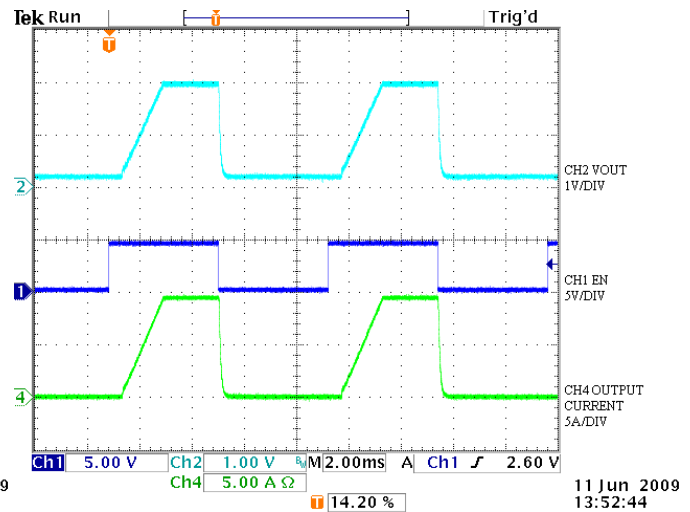

Figure 8. Start up when 12V bus is present and 5V is started up



#### TARGET SPECIFICATION

#### EFFICIENCY

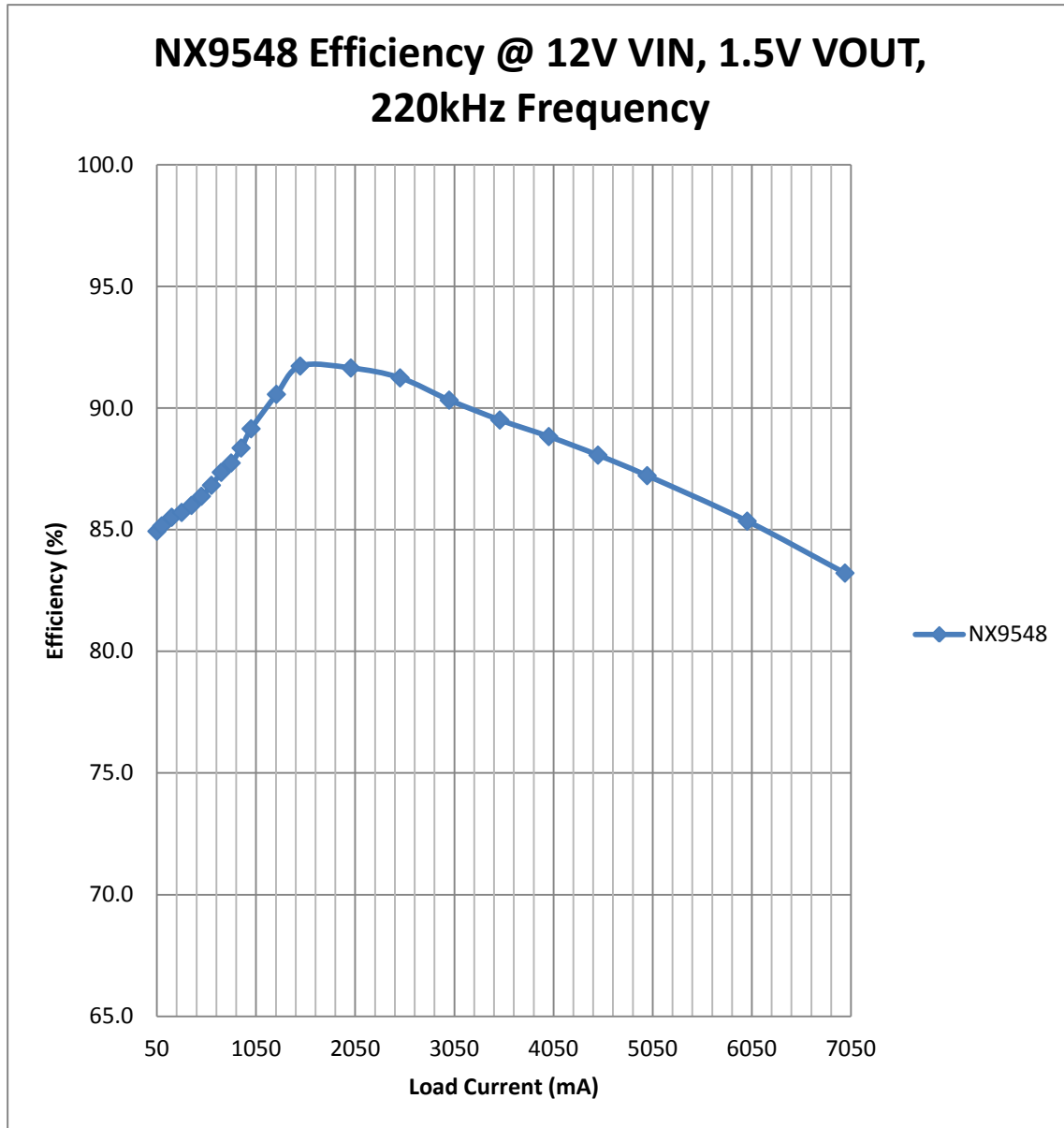

Figure 9. NX9548 Efficiency with 12V VIN, 1.5V VOUT @220kHz Fs



#### TARGET SPECIFICATION

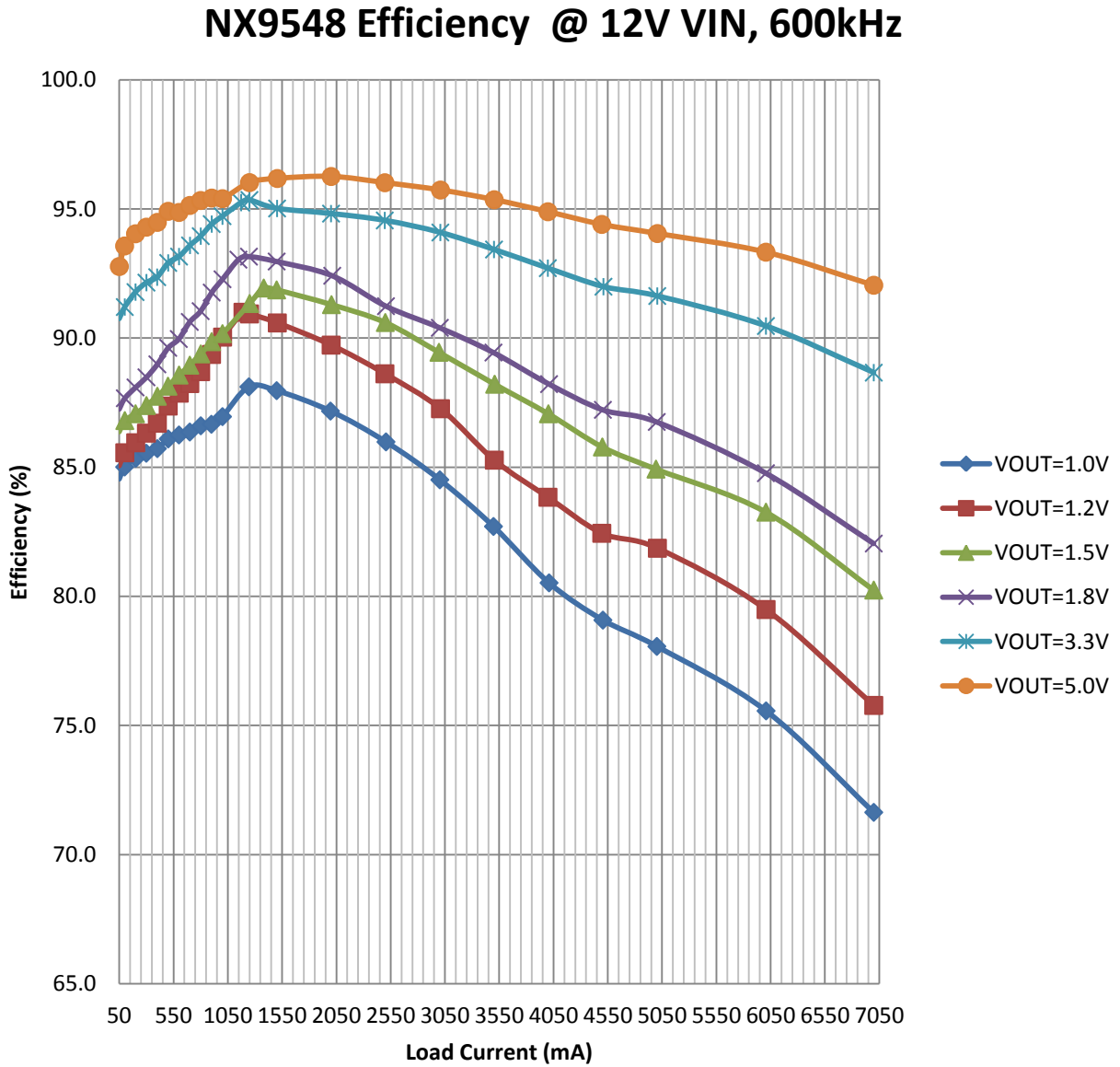

Figure 10. NX9548 Efficiency with 12V VIN @ 600kHz Fs



#### TARGET SPECIFICATION

#### DEMOBOARD SCHEMATIC

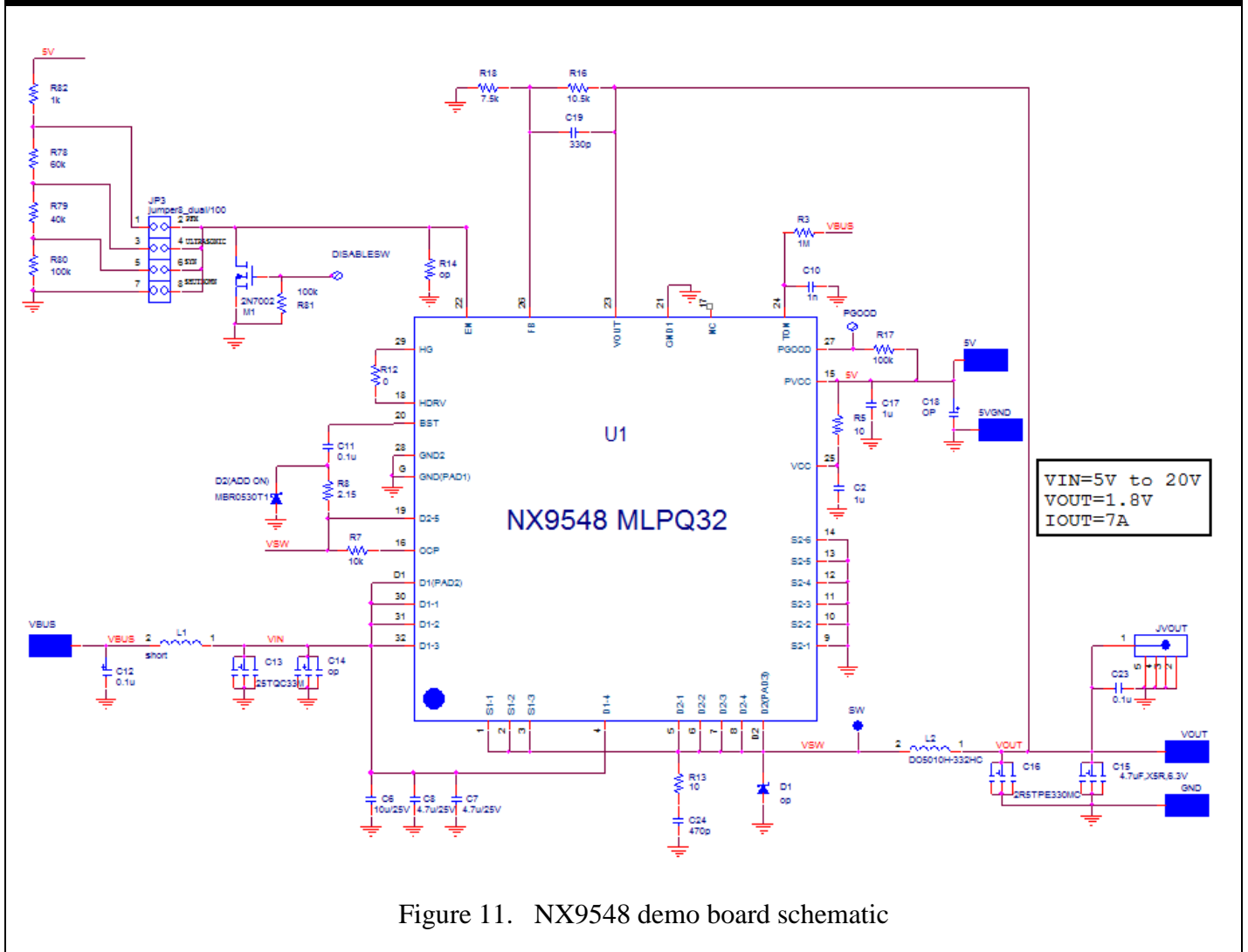

Figure 11. NX9548 demo board schematic



#### TARGET SPECIFICATION

#### DEMOBOARD LAYOUT

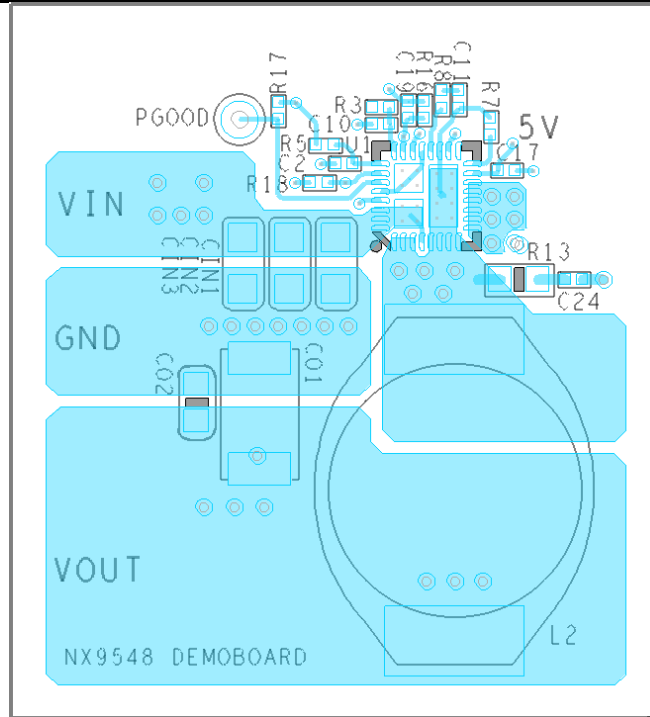

Figure 12. Top Layer

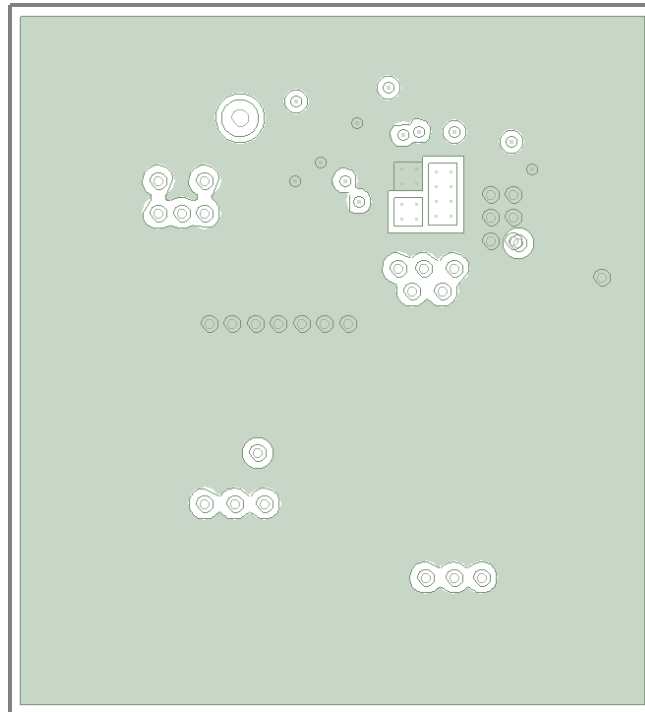

Figure 13. Ground Layer



#### TARGET SPECIFICATION

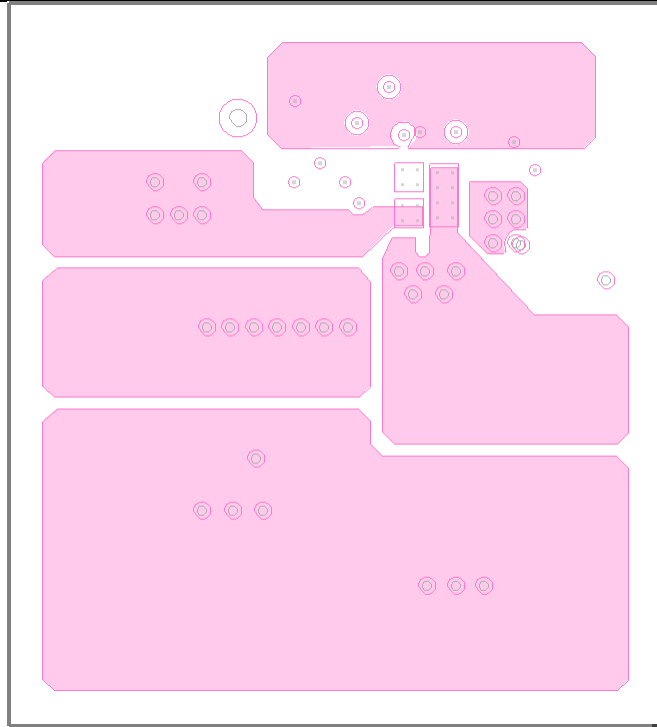

Figure 14. Power Layer

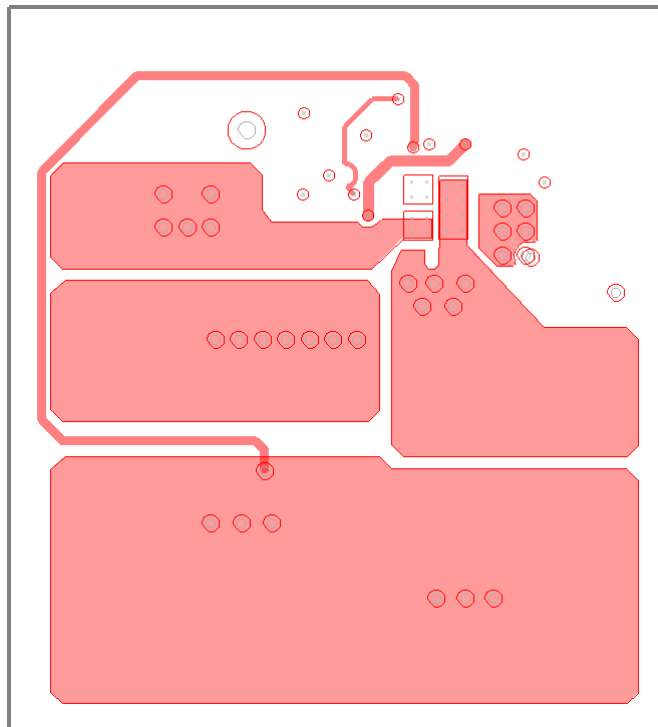

Figure 15. Bottom Layer



#### TARGET SPECIFICATION

#### PACKAGE DIMENSIONS

#### LD 8 Pin Plastic DFN 2x2 mm Dual Exposed Pad

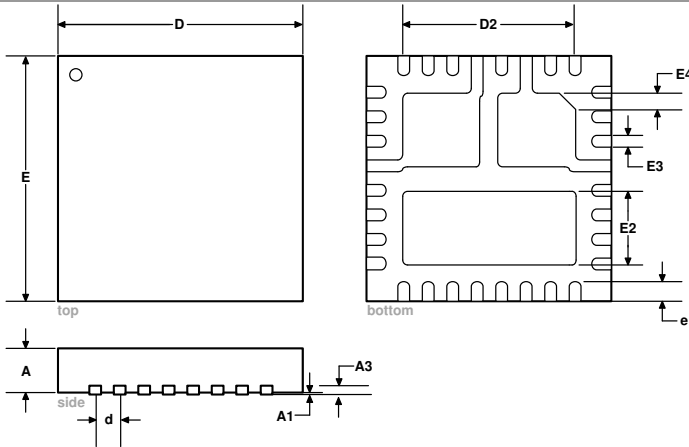

| Dim | MILLIMETERS |       | INCHES     |        |
|-----|-------------|-------|------------|--------|
|     | MIN         | MAX   | MIN        | MAX    |
| A   | 0.90        |       | 0.0354     |        |
| A1  | 0           | 0.05  | 0          | 0.0020 |
| A3  | 0.203 ref   |       | 0.0079 ref |        |
| d   | 0.50Bsc     |       | 0.0197     |        |
| D   | 4.950       | 5.050 | 0.1949     | 0.1989 |
| E   | 4.950       | 5.050 | 0.1949     | 0.1989 |
| D2  | 3.400       | 3.500 | 0.1339     | 0.1378 |
| e   | 0.350       | 0.450 | 0.0138     | 0.0177 |
| E2  | 1.475       | 1.575 | 0.0581     | 0.0620 |
| E3  | 0.200       | 0.300 | 0.0079     | 0.0118 |
| E4  | 0.300       |       | 0.0118     |        |

#### Note:

1. Dimensions do not include mold flash or protrusions; these shall not exceed 0.155mm (.006") on any side. Lead dimension shall not include solder coverage.
2. Dimensions are in mm, inches are for reference only.