

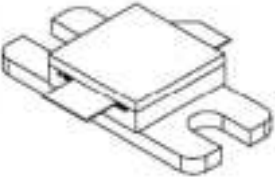

3134-65M

65Watts, 34 Volts, 200us, 10%
Radar 3100-3400 MHz

<p>GENERAL DESCRIPTION</p> <p>The 3134-65M is an internally matched, COMMON BASE bipolar transistor capable of providing 65Watts of pulsed RF output power at 200us pulse width, 10% duty factor across the 3100 to 3400 MHz band. This ceramic sealed transistor is specifically designed for S-band radar applications. It utilizes gold metallization and emitter ballasting to provide high reliability and supreme ruggedness.</p>	<p>CASE OUTLINE Common Base</p> 
<p>ABSOLUTE MAXIMUM RATINGS</p> <p>Maximum Voltage and Current</p> <p>Collector to Base Voltage (BV_{ces}) 65 V Emitter to Base Voltage (BV_{ebo}) 3.0 V Peak Collector Current (I_c) 7 A</p> <p>Maximum Temperatures</p> <p>Storage Temperature -65 to +200 °C Operating Junction Temperature +200 °C</p>	

ELECTRICAL CHARACTERISTICS @ 25°C

SYMBOL	CHARACTERISTICS	TEST CONDITIONS	MIN	TYP	MAX	UNITS
P_{out}	Power Output	F=3100-3400 MHz	65	70		W
P_g	Power Gain	Pulse Width = 200us	8.0	8.5		dB
η_c	Collector Efficiency	Duty Factor = 10 %	45			%
R_l	Return Loss	Power Input = 10.3W	-7			dB
VSWR-S	Load Mismatch Stability	$V_{cc} = +34V$			1.5:1	
VSWR-T	Load Mismatch Tolerance	F = 3100, 3300, 3400 MHz			2.0:1	

FUNCTIONAL CHARACTERISTICS @ 25°C

I_{ces}	Collector to Emitter Leakage	$V_{ce}=36V$			5	mA
BV_{ces}	Collector to Emitter Breakdown	$I_c = 30 \text{ mA}$	65			V
θ_{jc}^1	Thermal Resistance				0.5	°C/W

Typical Test Data:

Frequency	Pin (W)	Pout (W)	Ic (A)	RL (dB)	Nc (%)	G (dB)
3100 MHz	10	72	0.49	-10	44	8.6
3200 MHz	10	78	0.51	-18	45	8.9
3300 MHz	10	77	0.47	-19	48	8.8
3400 MHz	10	72	0.43	-18	49	8.5



3134-65M

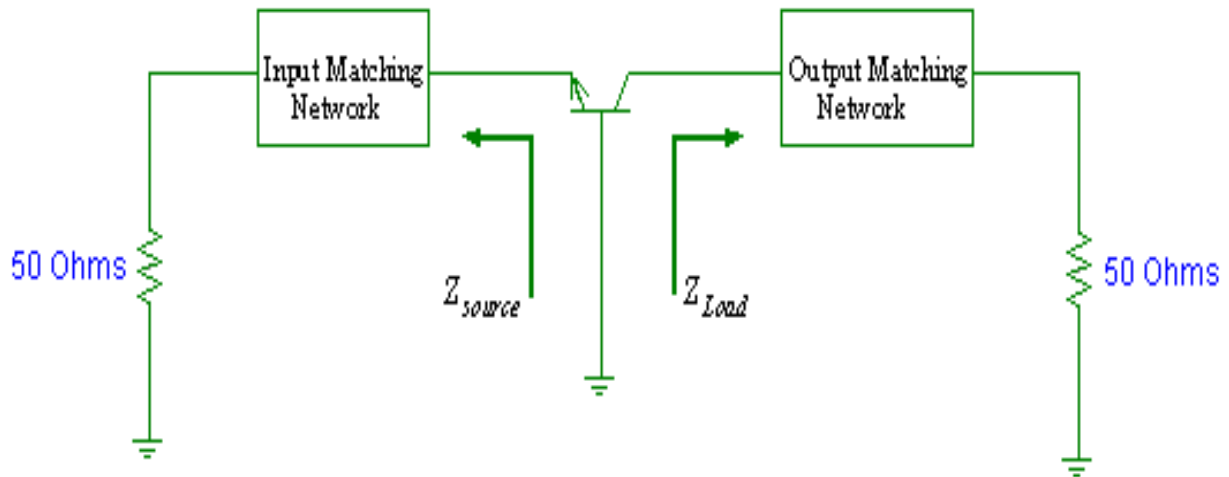

Broadband Test Fixture Impedance

Frequency (GHz)	Z_{in}	Z_{out}
3.1	$10.34 - j 7.88$	$6.72 - j 10.80$
3.2	$10.27 - j 7.34$	$6.56 - j 10.46$
3.3	$10.24 - j 6.82$	$6.41 - j 10.14$
3.4	$10.23 - j 6.32$	$6.28 - j 9.84$



3134-65M

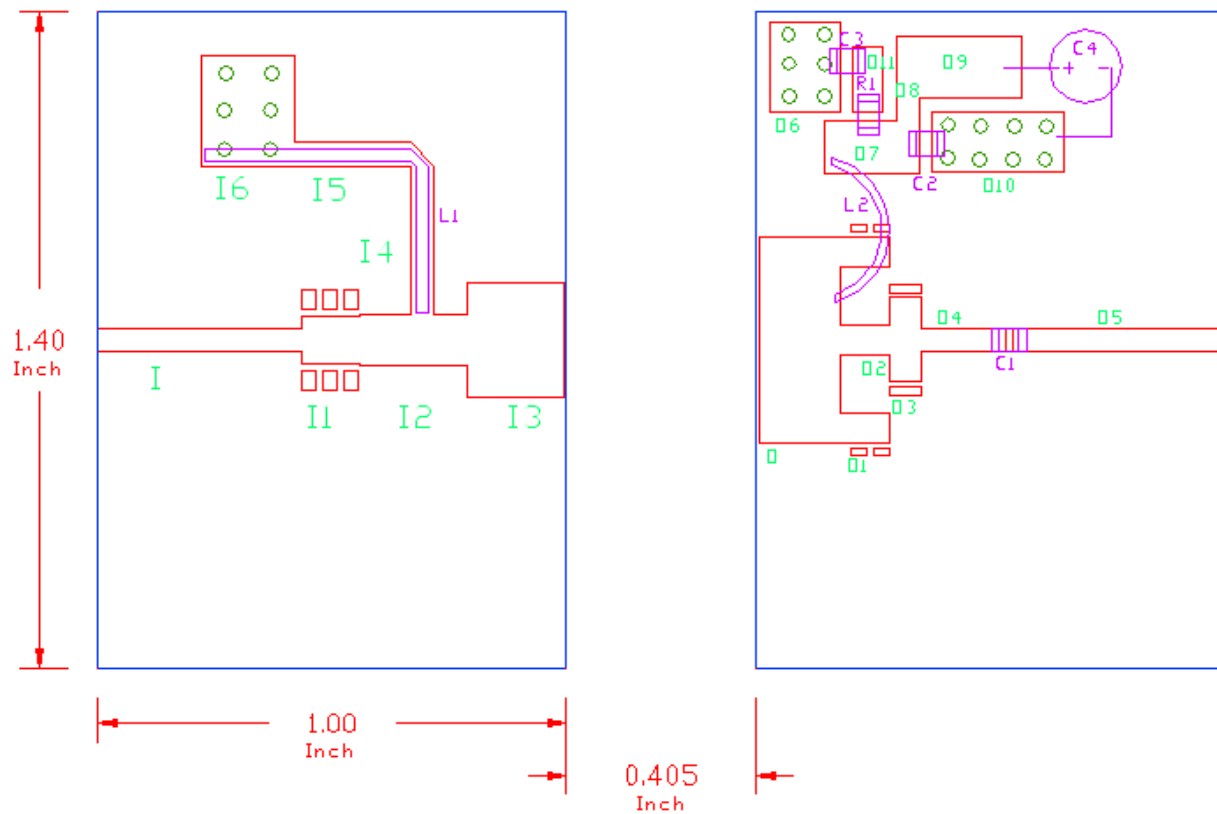

Input Matching Network			Output Matching Network			Circuit & Components	
Item	W (mil)	L (mil)	Item	W (mil)	L (mil)	Item	Value
I1	51	434	O1	64	105	C1	9.1pF (A size)
I2	110	232	O2	62	105	C2	100pF (A size)
I3	242	205	O3	180	66	C3	10,000pF (B size)
I4	51	315	O4	51	180	C4	1000uF (electrolytic)
I5	51	248	O5	51	430	R1	8.2 ohms (size 0805)
I6	238	200	O6	190	150	L1	Copper wire, 20 AWG, L=600 Mils
			O7	110	200	L2	Copper wire, 20 AWG, L=560 Mils
			O8	50	50	Board	Duroid 6002 @ 20 Mils, Er=2.94
			O9	130	260		
			O10	130	280		
			O11	140	62		

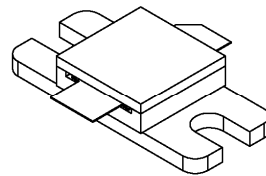
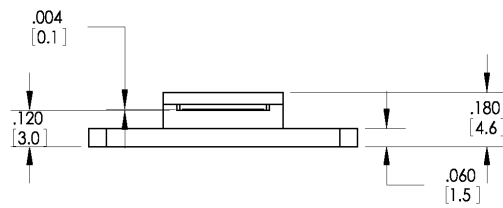
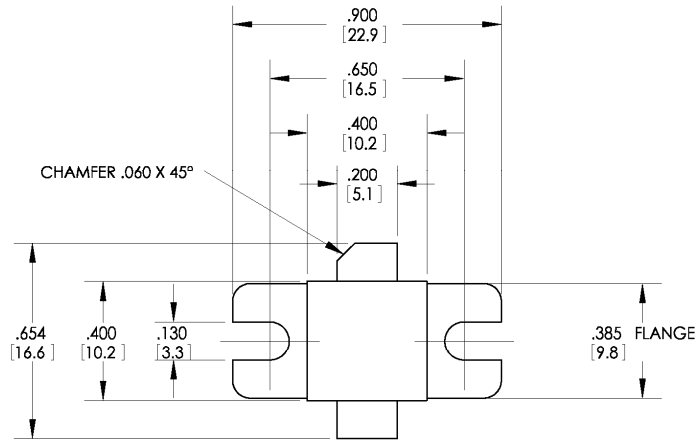

DWG NO.:

A57