

MSAGX75F60A

Features

- Rugged polysilicon gate cell structure
- high current handling capability, latch-proof
- Hermetically sealed, surface mount power package
- Low package inductance
- Very low thermal resistance
- Reverse polarity available upon request: MSAGX75F60B
- high frequency IGBT, low switching losses

600 Volts
75 Amps
2.7 Volts vce(sat)

N-CHANNEL
INSULATED GATE
BIPOLAR TRANSISTOR

Maximum Ratings @ 25°C (unless otherwise specified)

DESCRIPTION	SYMBOL	MAX.	UNIT
Collector-to-Emitter Breakdown Voltage (Gate Shorted to Emitter) @ $T_J \geq 25^\circ\text{C}$	BV_{CES}	600	Volts
Collector-to-Gate Breakdown Voltage @ $T_J \geq 25^\circ\text{C}$, $R_{GS} = 1\text{ M}\Omega$	BV_{CGR}	600	Volts
Continuous Gate-to-Emitter Voltage	V_{GES}	+/-20	Volts
Transient Gate-to-Emitter Voltage	V_{GEM}	+/-30	Volts
Continuous Collector Current $T_J = 25^\circ\text{C}$	I_{C25}	75	Amps
90°C	I_{C90}	50	
Peak Collector Current, pulse width limited by T_{jmax}	I_{CM}	200	Amps
Safe Operating Area (RBSOA) @ $V_{GE} = 15\text{V}$, $L = 30\mu\text{H}$ (clamped inductive load), $R_G = 2.7\Omega$, $T_J = 125^\circ\text{C}$, $V_{CE} = 0.8 \times V_{CES}$	I_{max}	100	Amps
Power Dissipation	P_D	300	Watts
Junction Temperature Range	T_J	-55 to +150	$^\circ\text{C}$
Storage Temperature Range	T_{stg}	-55 to +150	$^\circ\text{C}$
Thermal Resistance, Junction to Case	θ_{JC}	0.25	$^\circ\text{C/W}$

Mechanical Outline

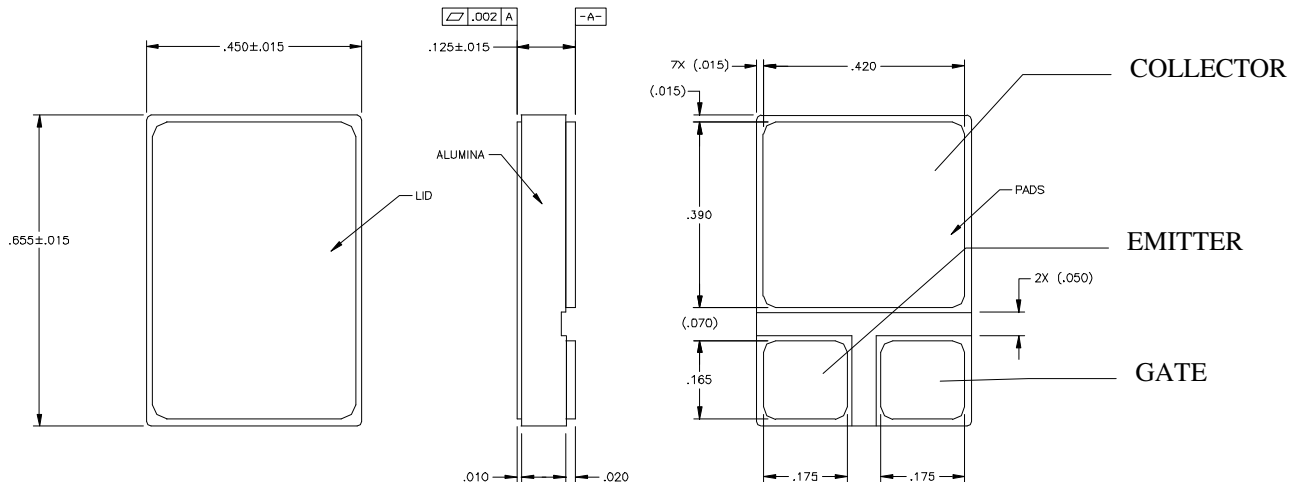

MSAGX75F60A

Electrical Parameters @ 25°C (unless otherwise specified)

DESCRIPTION	SYMBOL	CONDITIONS	MIN	TYP.	MAX	UNIT
Collector-to-Emitter Breakdown Voltage (Gate Shorted to Emitter)	BV_{CES}	$V_{GS} = 0\text{ V}, I_C = 250\ \mu\text{A}$	600			V
Gate Threshold Voltage	$V_{GE(th)}$	$V_{CE} = V_{GE}, I_C = 250\ \mu\text{A}$	2.5		5.0	V
Gate-to-Emitter Leakage Current	I_{GES}	$V_{GE} = \pm 20V_{DC}, V_{CE} = 0$ $T_J = 25^\circ\text{C}$ $T_J = 125^\circ\text{C}$			± 100 ± 200	nA
Collector-to-Emitter Leakage Current (Zero Gate Voltage Collector Current)	I_{CES}	$V_{CE} = 0.8 \cdot BV_{CES}$ $V_{GE} = 0\text{ V}$ $T_J = 25^\circ\text{C}$ $T_J = 125^\circ\text{C}$			200 1000	μA
Collector-to-Emitter Saturation Voltage (1)	$V_{CE(sat)}$	$V_{GE} = 15\text{ V}, I_C = 50\text{ A}$ $I_C = 50\text{ A}$ $T_J = 25^\circ\text{C}$ $T_J = 125^\circ\text{C}$		2.5	2.7	V
Forward Transconductance (1)	g_{fs}	$V_{CE} \geq 10\text{ V}; I_C = 50\text{ A}$	25	35		S
Input Capacitance	C_{ies}	$V_{GE} = 0\text{ V}, V_{CE} = 25\text{ V}, f = 1\text{ MHz}$		4000		pF
Output Capacitance	C_{oes}			340		
Reverse Transfer Capacitance	C_{res}			100		
INDUCTIVE LOAD, $T_J = 25^\circ\text{C}$						
Turn-on Delay Time	$t_{d(on)}$	$V_{GE} = 15\text{ V}, V_{CE} = 480\text{ V},$ $I_C = 50\text{ A}, R_G = 2.7\ \Omega,$ $L = 100\ \mu\text{H}$ note 2, 3		50		ns
Rise Time	t_{ri}			210		ns
Turn-off Delay Time	$t_{d(off)}$			200		ns
Fall Time	t_{fi}			275	400	ns
Off Energy	E_{off}			4.8		mJ
INDUCTIVE LOAD, $T_J = 125^\circ\text{C}$						
Turn-on Delay Time	$t_{d(on)}$	$V_{GE} = 15\text{ V}, V_{CE} = 480\text{ V},$ $I_C = 50\text{ A}, R_G = 2.7\ \Omega,$ $L = 100\ \mu\text{H}$ note 2, 3		50		ns
Rise Time	t_{ri}			240		ns
On Energy	E_{on}			3		mJ
Turn-off Delay Time	$t_{d(off)}$			280		ns
Fall Time	t_{fi}			600		ns
Off Energy	E_{off}		9.6		mJ	
Total Gate Charge	Q_g	$V_{GE} = 15\text{ V}, V_{CE} = 300\text{ V}, I_C = 50\text{ A}$		200	250	nC
Gate-to-Emitter Charge	Q_{ge}			35	50	
Gate-to-Collector (Miller) Charge	Q_{gc}			80	100	

Notes

- (1) Pulse test, $t \leq 300\ \mu\text{s}$, duty cycle $\delta \leq 2\%$
- (2) switching times and losses may increase for larger V_{CE} and/or R_G values or higher junction temperatures.
- (3) switching losses include "tail" losses
- (4) Microsemi Corp. does not manufacture the igbt die; contact company for details.