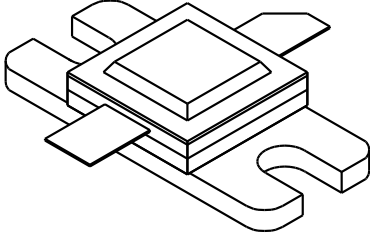

1214 - 55

55 Watts - 28 Volts, Pulsed
Radar 1200 - 1400 MHz

<p>GENERAL DESCRIPTION The 1214-55 is an internally matched, COMMON BASE transistor capable of providing 55 Watts of pulsed RF output power at two milliseconds pulse width, twenty percent duty factor across the band 1200 to 1400 MHz. This hermetically solder-sealed transistor is specifically designed for L-Band radar applications. It utilizes gold metalization and diffused emitter ballasting to provide high reliability and supreme ruggedness.</p>	<p>CASE OUTLINE 55AW, STYLE 1</p> 													
<p>ABSOLUTE MAXIMUM RATINGS Maximum Power Dissipation @ 25°C 175 Watts</p> <p>Maximum Voltage and Current</p> <table style="width: 100%; border: none;"> <tr> <td style="width: 15%;">BVces</td> <td style="width: 55%;">Collector to Emitter Voltage</td> <td style="width: 30%; text-align: right;">50 Volts</td> </tr> <tr> <td>BVebo</td> <td>Emitter to Base Voltage</td> <td style="text-align: right;">3.5 Volts</td> </tr> <tr> <td>Ic</td> <td>Collector Current</td> <td style="text-align: right;">8 Amps</td> </tr> </table> <p>Maximum Temperatures</p> <table style="width: 100%; border: none;"> <tr> <td style="width: 60%;">Storage Temperature</td> <td style="text-align: right;">- 65 to + 200°C</td> </tr> <tr> <td>Operating Junction Temperature</td> <td style="text-align: right;">+ 200°C</td> </tr> </table>	BVces	Collector to Emitter Voltage	50 Volts	BVebo	Emitter to Base Voltage	3.5 Volts	Ic	Collector Current	8 Amps	Storage Temperature	- 65 to + 200°C	Operating Junction Temperature	+ 200°C	
BVces	Collector to Emitter Voltage	50 Volts												
BVebo	Emitter to Base Voltage	3.5 Volts												
Ic	Collector Current	8 Amps												
Storage Temperature	- 65 to + 200°C													
Operating Junction Temperature	+ 200°C													

ELECTRICAL CHARACTERISTICS @ 25 °C

SYMBOL	CHARACTERISTICS	TEST CONDITIONS	MIN	TYP	MAX	UNITS
Pout	Power Out	F = 1200-1400 MHz	55			Watts
Pin	Power Input	Vcc = 28 Volts			12.3	Watts
Pg	Power Gain	Pulse Width = 2 ms	6.5	7.0		dB
ηc	Collector Efficiency	Duty = 20 %		45		%
VSWR	Load Mismatch Tolerance	F=1300MHz, Po=55W			3:1	

BVces	Collector to Emitter Breakdown	Ic = 100 mA	50			Volts
BVebo	Emitter to Base Breakdown	Ie = 15 mA	3.5			Volts
Hfe	DC Current Gain	Vce = 5 V, Ic = 1000 mA	20	45		
θjc	Thermal Resistance	Rated Pulse Condition			1.0	°C/W

Issue August 1996

GHz TECHNOLOGY INC. RESERVES THE RIGHT TO MAKE CHANGES WITHOUT FURTHER NOTICE. GHz RECOMMENDS THAT BEFORE THE PRODUCT(S) DESCRIBED HEREIN ARE WRITTEN INTO SPECIFICATIONS, OR USED IN CRITICAL APPLICATIONS, THAT THE PERFORMANCE CHARACTERISTICS BE VERIFIED BY CONTACTING THE FACTORY.

POWER OUTPUT vs POWER INPUT

Vcc = 28 V, PW = 2 ms, 20%

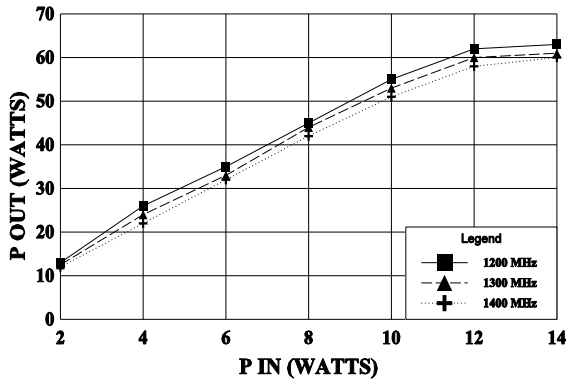

POWER OUPUT AND EFF. vs FREQUENCY

Vcc = 28 V, Pin = 12.3 W, 2 ms, 20%

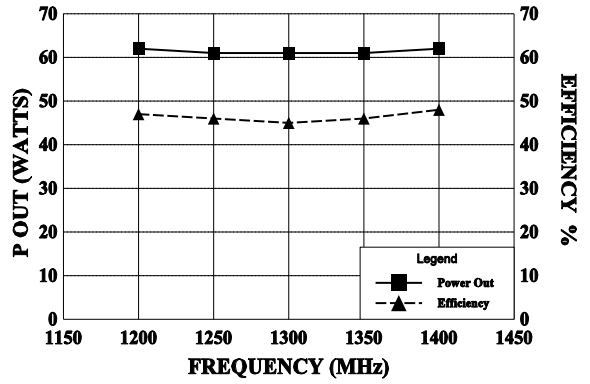

Typical Impedances

INPUT IMPEDANCE vs FREQUENCY

Zin = R + jX (Vcc = 28 V, Pin = 12 W)

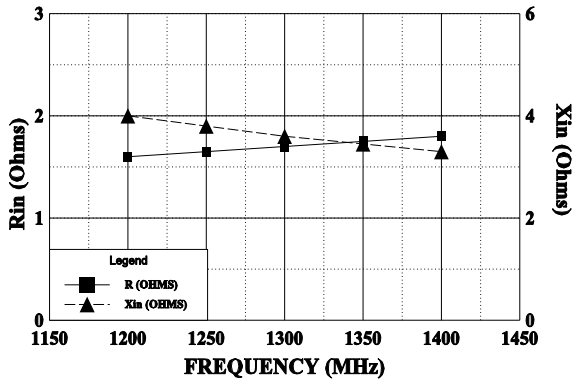

LOAD IMPEDANCE vs FREQUENCY

Zcl = Rcl - jXcl (Vcc = 28 V, Pin=12 W)

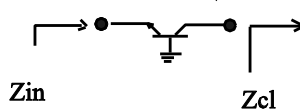
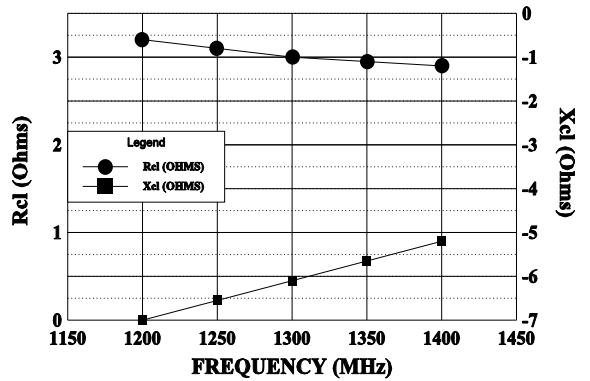

REVISIONS

ZONE	REV	DESCRIPTION	DATE	APPROVED
------	-----	-------------	------	----------

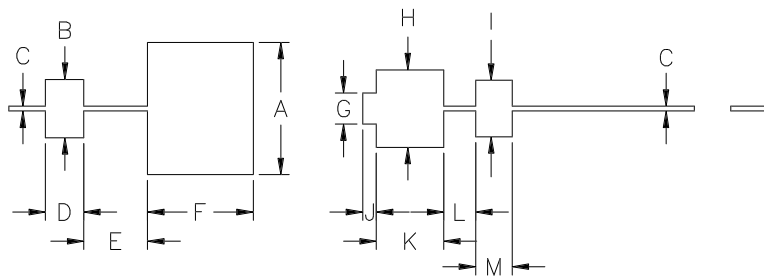

DIM	INCHES
A	.725
B	.320
C	.027
D	.170
E	.350
F	.310
G	.170
H	.425
I	.310
J	.075
K	.370
L	.175
M	.200

1214-55 TEST AMPLIFIER
1200 - 1400 MHz BANDWIDTH

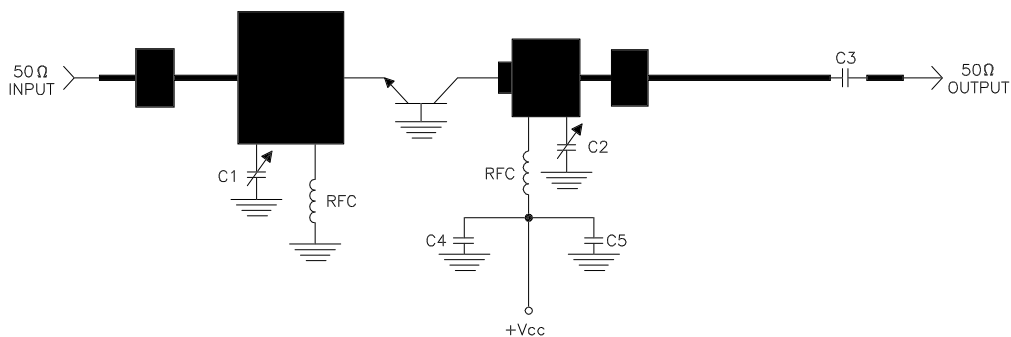

- = Microstrip on 0.010" Duroid, Er=2.3
- C1 = 0.6-6.5pF JOHANSON VARIABLE
- C2 = 0.3-3.5pF JOHANSON VARIABLE
- C3 = 82pF ATC CHIP CAP
- C4 = 82pF ATC CHIP CAP
- C5 = 2000 mFD



CAGE OPJR2	DWG NO. 1214-55	REV A
	SCALE 1/1	SHEET