

**MSAER12N50A**  
**MSAFR12N50A**

**Features**

- Ultrafast rectifier in parallel with the body diode (MSAE type only)
- Rugged polysilicon gate cell structure
- Increased Unclamped Inductive Switching (UIS) capability
- Hermetically sealed, surface mount power package
- Low package inductance
- Very low thermal resistance
- Reverse polarity available upon request

**500 Volts**  
**12 Amps**  
**400 mΩ**

**N-CHANNEL**  
**ENHANCEMENT MODE**  
**POWER MOSFET**

**Maximum Ratings @ 25°C (unless otherwise specified)**

DESCRIPTION	SYMBOL	MAX.	UNIT
Drain-to-Source Breakdown Voltage (Gate Shorted to Source) @ T <sub>J</sub> ≥ 25°C	BV <sub>DSS</sub>	500	Volts
Drain-to-Gate Breakdown Voltage @ T <sub>J</sub> ≥ 25°C, R <sub>GS</sub> = 1 MΩ	BV <sub>DGR</sub>	500	Volts
Continuous Gate-to-Source Voltage	V <sub>GS</sub>	+/-20	Volts
Transient Gate-to-Source Voltage	V <sub>GSM</sub>	+/-30	Volts
Continuous Drain Current 100°C	I <sub>D25</sub> I <sub>D100</sub>	12 8	Amps
Peak Drain Current, pulse width limited by T <sub>Jmax</sub>	I <sub>DM</sub>	48	Amps
Repetitive Avalanche Current	I <sub>AR</sub>	12	Amps
Repetitive Avalanche Energy	E <sub>AR</sub>	tbd	mJ
Single Pulse Avalanche Energy	E <sub>AS</sub>	8	mJ
Voltage Rate of Change of the Recovery Diode @ I <sub>S</sub> ≤ I <sub>DM</sub> , di/dt ≤ 100 A/μs, V <sub>DD</sub> ≤ V <sub>DSS</sub> , T <sub>J</sub> ≤ 150°C	dv/dt	3.5	V/ns
Power Dissipation	P <sub>D</sub>	300	Watts
Junction Temperature Range	T <sub>J</sub>	-55 to +150	°C
Storage Temperature Range	T <sub>stg</sub>	-55 to +150	°C
Continuous Source Current (Body Diode)	I <sub>S</sub>	12	Amps
Pulse Source Current (Body Diode)	I <sub>SM</sub>	48	Amps
Thermal Resistance, Junction to Case	θ <sub>JC</sub>	0.4	°C/W

**Mechanical Outline**

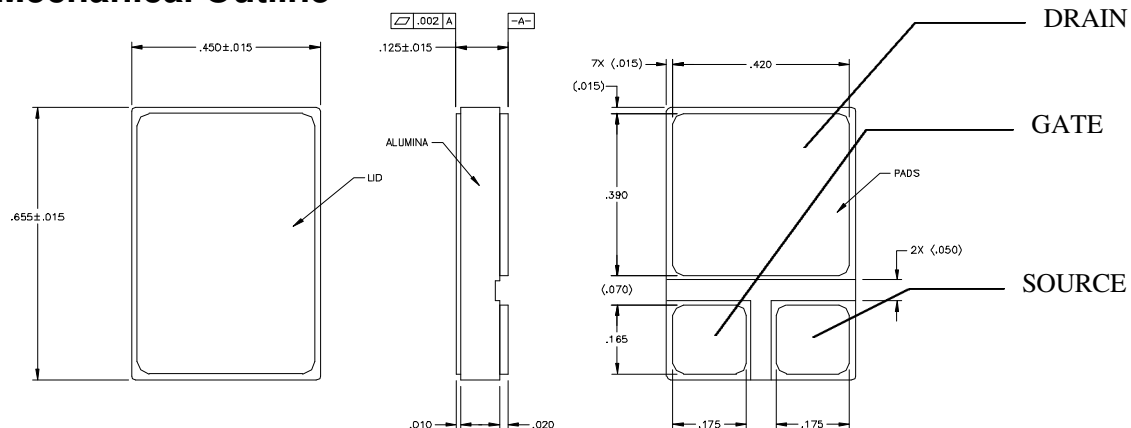

# MSAER12N50A MSAFR12N50A

## Electrical Parameters @ 25°C (unless otherwise specified)

DESCRIPTION	SYMBOL	CONDITIONS	MIN	TYP.	MAX	UNIT
Drain-to-Source Breakdown Voltage (Gate Shorted to Source)	$BV_{DSS}$	$V_{GS} = 0\text{ V}, I_D = 1000\ \mu\text{A}$	500			V
Temperature Coefficient of the Drain-to-Source Breakdown Voltage	$\Delta BV_{DSS}/\Delta T_J$			0.78		V/°C
Gate Threshold Voltage	$V_{GS(th)}$	$V_{DS} = V_{GS}, I_D = 1\text{ mA}$	2.0		4.0	V
Gate-to-Source Leakage Current	$I_{GSS}$	$V_{GS} = \pm 20V_{DC}, V_{DS} = 0\text{ V}, T_J = 25^\circ\text{C}$ $T_J = 125^\circ\text{C}$			$\pm 100$ $\pm 200$	nA
Drain-to-Source Leakage Current (Zero Gate Voltage Drain Current)	$I_{DSS}$	$V_{DS} = 0.8 \cdot BV_{DSS}, T_J = 25^\circ\text{C}$ $V_{GS} = 0\text{ V}, T_J = 125^\circ\text{C}$			25 250	$\mu\text{A}$
Static Drain-to-Source On-State Resistance (1)	$R_{DS(on)}$	$V_{GS} = 10\text{ V}, I_D = 8\text{ A}, T_J = 25^\circ\text{C}$ $I_D = 12\text{ A}, T_J = 25^\circ\text{C}$ $I_D = 8\text{ A}, T_J = 125^\circ\text{C}$		0.800	0.400 0.500	$\Omega$
Forward Transconductance (1)	$g_{fs}$	$V_{DS} \geq 15\text{ V}, I_D = 8\text{ A}$	5.5			S
Input Capacitance Output Capacitance Reverse Transfer Capacitance	$C_{iss}$ $C_{oss}$ $C_{rss}$	$V_{GS} = 0\text{ V}, V_{DS} = 25\text{ V}, f = 1\text{ MHz}$		2700 600 240		pF
Turn-on Delay Time Rise Time Turn-off Delay Time Fall Time	$T_{d(on)}$ $t_r$ $t_{d(off)}$ $t_f$	$V_{GS} = 10\text{ V}, V_{DS} = 250\text{ V},$ $I_D = 12\text{ A}, R_G = 2.35\ \Omega$			35 190 170 130	ns
Total Gate Charge Gate-to-Source Charge Gate-to-Drain (Miller) Charge	$Q_{g(on)}$ $Q_{gs}$ $Q_{gd}$	$V_{GS} = 10\text{ V}, V_{DS} = 250\text{ V}, I_D = 12\text{ A}$	55 5 27		120 19 70	nC
Body Diode Forward Voltage (1)	$V_{SD}$	$I_F = I_S, V_{GS} = 0\text{ V}$ MSAE MSAF			1.2 1.7	V
Reverse Recovery Time (Body Diode)	$t_{rr}$	$I_F = 10\text{ A},$ $-di/dt = 100\text{ A}/\mu\text{s},$ MSAE MSAF			70 1600	ns
Reverse Recovery Charge	$Q_{rr}$	$I_F = 10\text{ A},$ $di/dt = 100\text{ A}/\mu\text{s},$ MSAE MSAF			tbd 14	$\mu\text{C}$

### Notes

- (1) Pulse test,  $t \leq 300\ \mu\text{s}$ , duty cycle  $\delta \leq 2\%$
- (2) Microsemi Corp. does not manufacture the mosfet die; contact factory for details