

1A SYNCHRONOUS BUCK SWITCHER WITH FET ON BOARD
PRODUCTION DATA SHEET
Pb Free Product
DESCRIPTION

The NX4110 is a current mode PWM buck switcher with internal compensation, can provide up to 1A output current with FET on board. It operates from 2.8V to 5.5V and output as low as 0.6V which is ideal for the application with single cell Li-Ion battery as well as other 3.3V input bus supply applications. Switching frequency is fixed 1MHz, small surface mount inductors and capacitors are allowed to use, make it good for portable applications.

NX4110 is available in 5-pin SOT23 package.

FEATURES

- SOT23-5L package
- Internal Digital Soft Start
- Internally-compensated Current mode controller
- Peak Current Limit with HICCUP Feature and Over Temperature Protection
- Prebias Start-up Operation
- Pgood Available
- Pb-free and RoHS compliant

APPLICATIONS

- Li-Ion battery operated portable system
- Cellular Phones
- Portable applications
- USB Devices

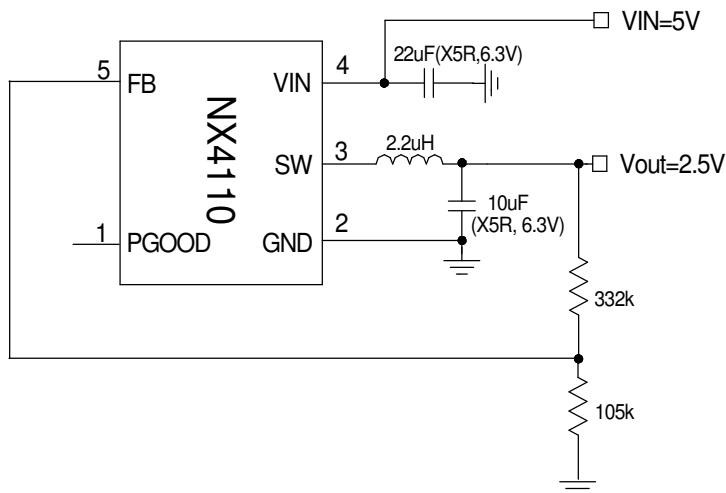
TYPICAL APPLICATION


Fig.1 - Typical application of NX4110CZ1TR

ORDERING INFORMATION

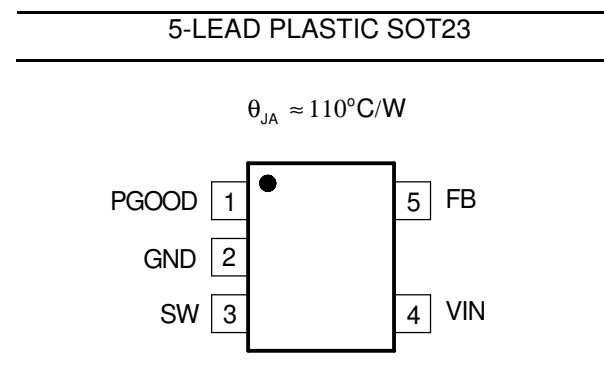
Device	Temperature	Package	Pb-Free
NX4110CZ1TR	-40°C to 85°C	SOT23-5L	Yes

ABSOLUTE MAXIMUM RATINGS

VIN to GND	-0.3V to 6V
SW,FB,PGOOD to GND	-0.3V to VIN + 0.3V
ESD Susceptibility	1kV
Lead Temperature(Soldering,10sec.)	300°C
Storage Temperature Range	-55°C to 150°C
Operating Junction Temperature Range	-40°C to 150°C

CAUTION: Stresses above those listed in "ABSOLUTE MAXIMUM RATINGS", may cause permanent damage to the device. This is a stress only rating and operation of the device at these or any other conditions above those indicated in the operational sections of this specification is not implied.

PACKAGE INFORMATION



ELECTRICAL SPECIFICATIONS

$V_{IN}=3.5\text{V}$. Typical data refers to $T_A=25^{\circ}\text{C}$. Unless otherwise specified.

PARAMETER	SYM	Test Condition	Min	TYP	MAX	Units
Reference Voltage						
Ref Voltage	V_{FB}		0.59	0.6	0.607	V
Line Regulation						
Line Regulation		$V_{IN}=3\text{V to }5\text{V}, V_{OUT}=1.8\text{V}, I_{OUT}=10\text{mA}$		2		mV
VIN UVLO						
VIN Rising Threshold			2.3	2.5	2.8	V
VIN Falling Threshold				2.3		V
Supply Voltage(VIN)						
VIN Input Voltage Range	V_{IN}		2.8		5.5	V
Quiescent Current	I_q	No Load, switching		4		mA
Oscillator (Rt)						
Frequency	F_S		800	1000	1200	kHz
Max Duty Cycle			78	86		%
Min ON time				100		nS
Error Amplifiers						
Feedback Input Bias Current					0.05	uA
SS						
Soft Start time	T_{SS}			500		uS

PARAMETER	SYM	Test Condition	Min	TYP	MAX	Units
Current Limit						
Current Limit Threshold				1.8		A
Thermal Shutdown						
Thermal shutdown trip point				155		°C
Hysteresis				15		°C
Internal Switch						
Rdson of Control FET		Vin=5V		400		mohm
		Vin=3.3V		480		
Rdson of Synchronous FET		Vin=5V		300		mohm
		Vin=3.3V		360		
PGOOD						
PGOOD low Threshold				85		%V _{REF}
PGOOD high Threshold voltage				90		%V _{REF}

PIN DESCRIPTIONS

PIN SYMBOL	PIN DESCRIPTION
SW	SW output. Junction of the internal high-side and low-side power MOSFETs, and output inductor.
GND	Ground Connection for Chip. Connect GND with large copper areas to the input and output supply returns, and negative terminals of the input and output capacitors.
FB	Error amplifier inverting input. Error amplifier inverting input. This pin is connected via resistor dividers to the output of the switching regulators to set the output DC voltage. A 332kohm resistor is recommended to be connected from VOUT and FB .
VIN	Supply voltage input for switcher. This pin needs minimum 22uF/X5R/6.3V as input capacitor.
PGOOD	PGOOD indicator. It requires a pull up resistor to Vcc or lower voltage. When FB pin reaches 90% of the reference voltage PGOOD transitions from LO to HI state.

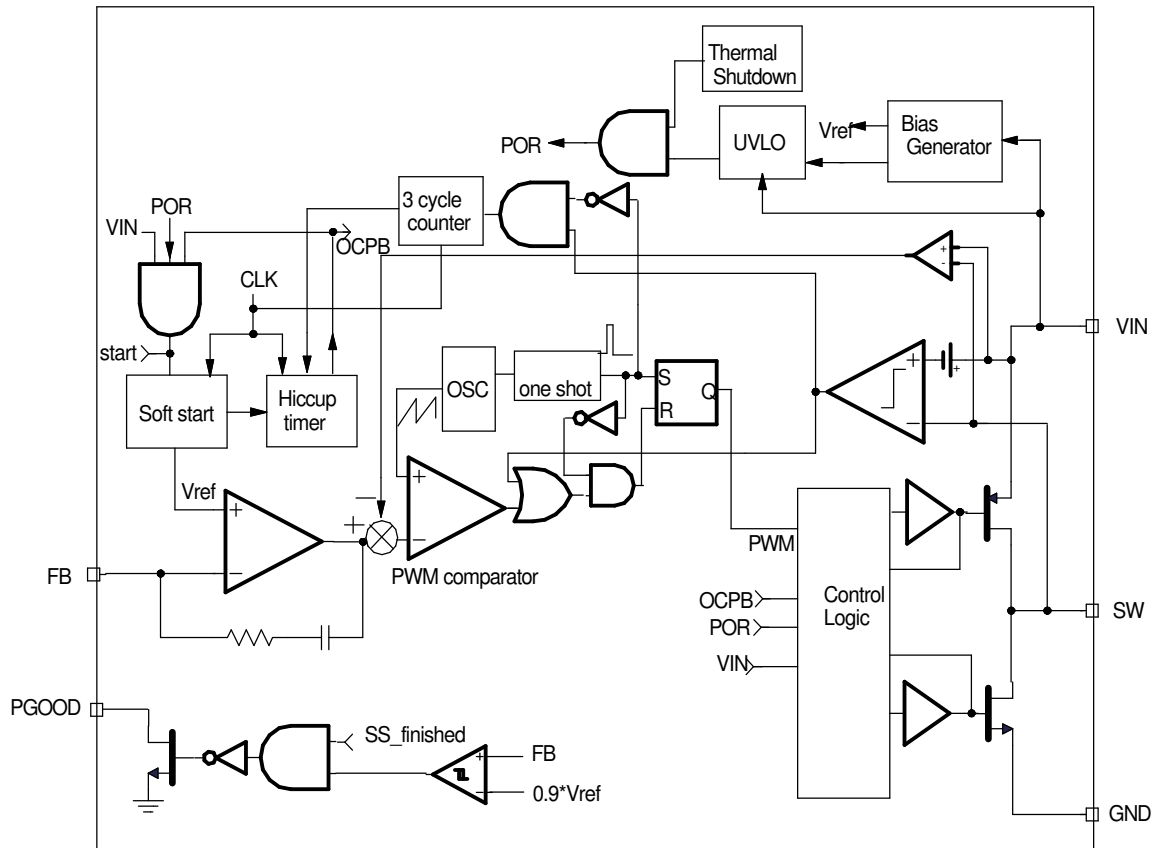
BLOCK DIAGRAM


Fig. 2 - Simplified block diagram of the NX4110

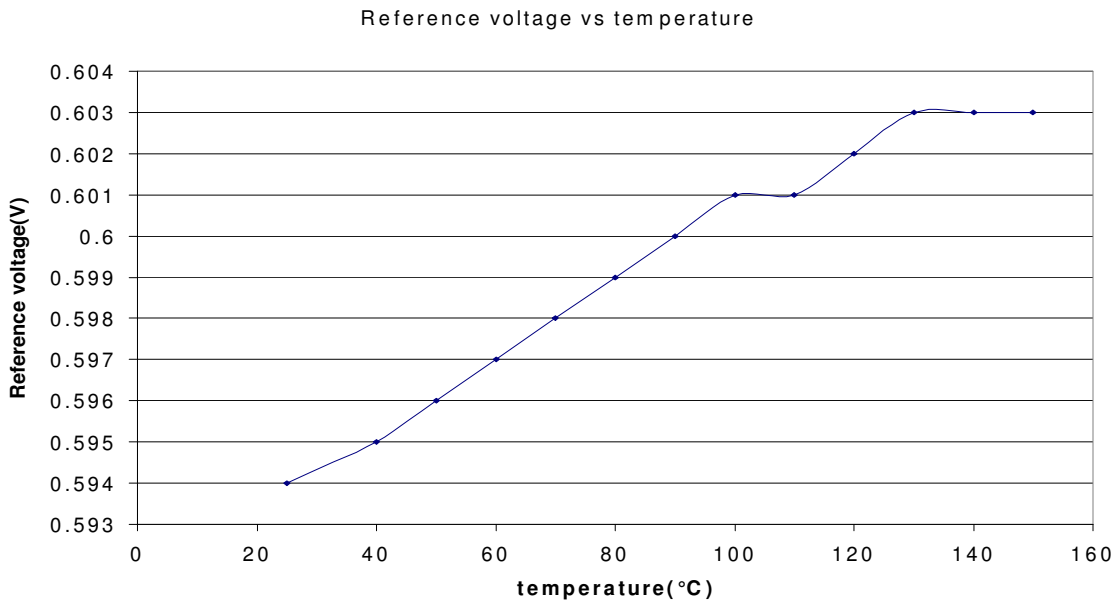
Typical Operating Characteristics


Fig.3 - Reference volateg vs temperature

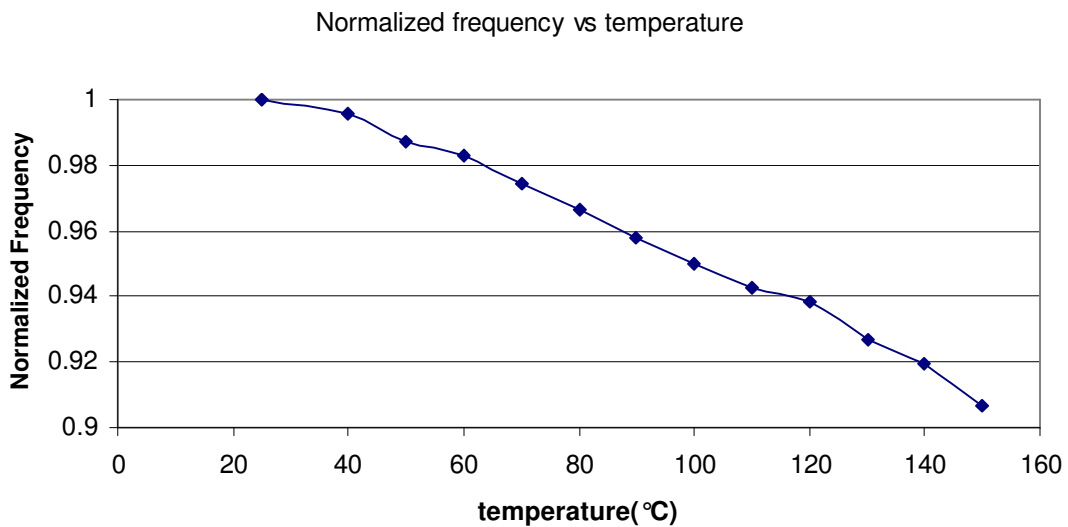


Fig.4 - Normalized frequency vs temperature

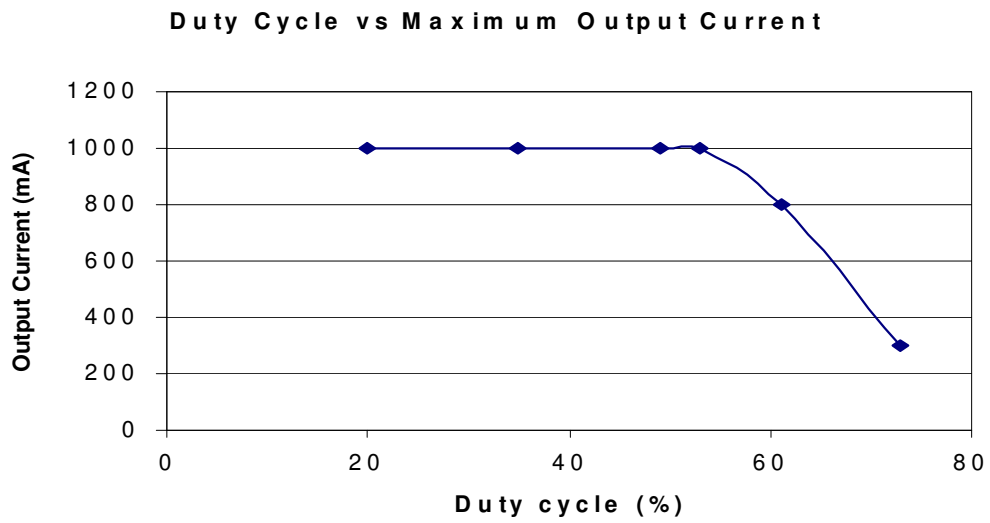


Fig.5 - Duty cycle vs maximum output current

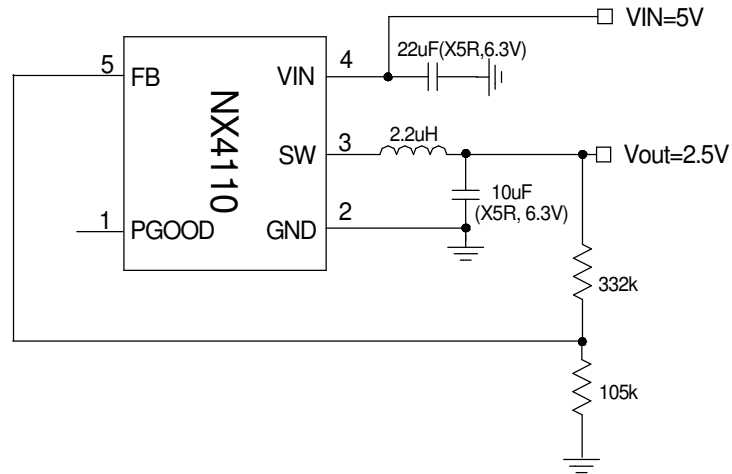
Typical Application(VOUT=2.5V)


Fig. 6 - Demo board schematic

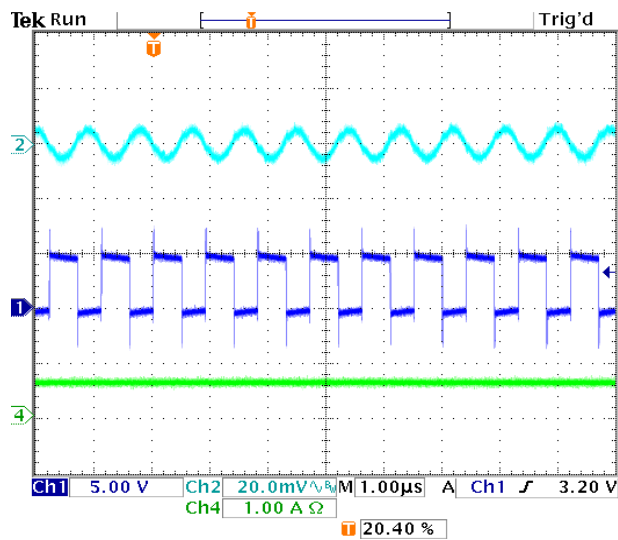


Fig. 7 - Output ripple

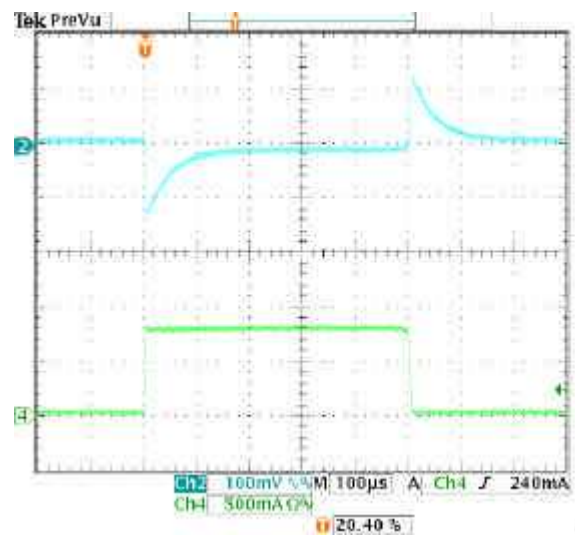


Fig. 8 - Transient response

Typical Application(VOUT=1.8V)

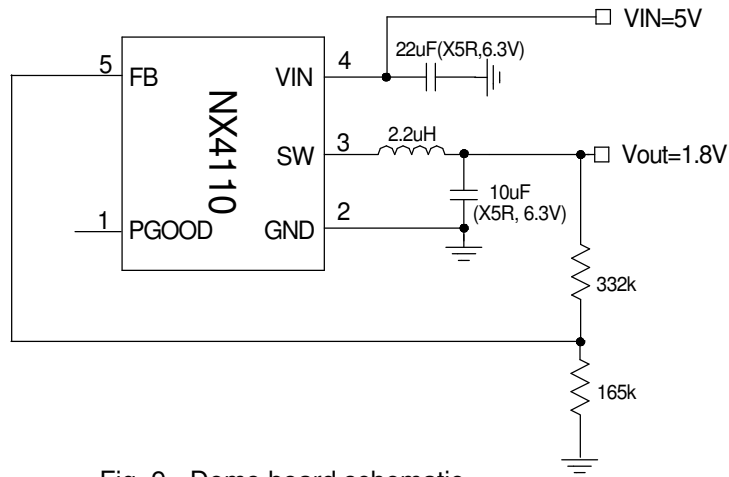


Fig. 9 - Demo board schematic

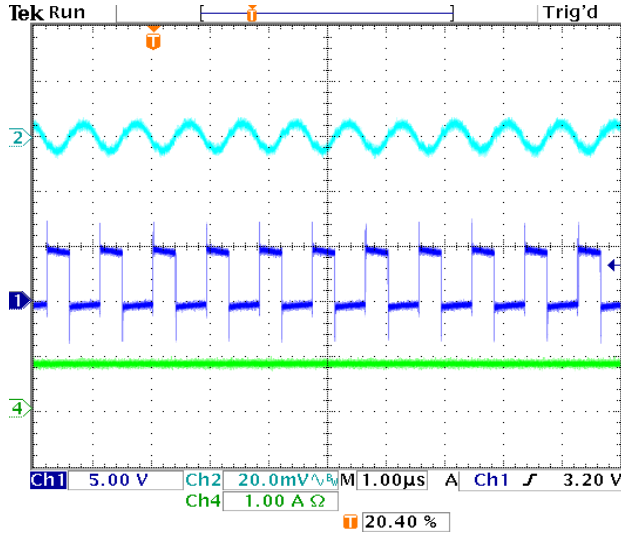


Fig. 10 - Output ripple

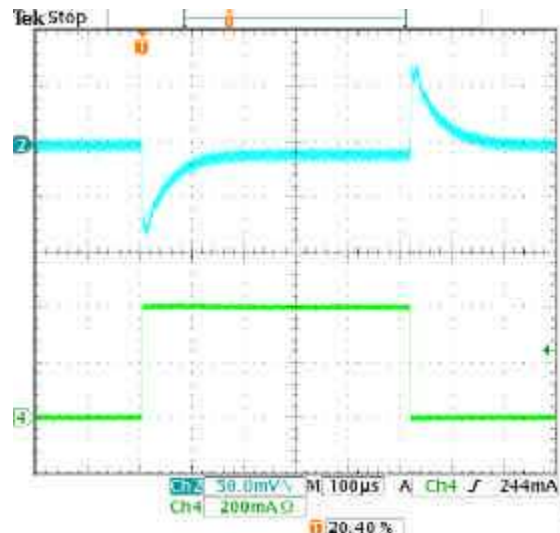


Fig. 11 - Transient response

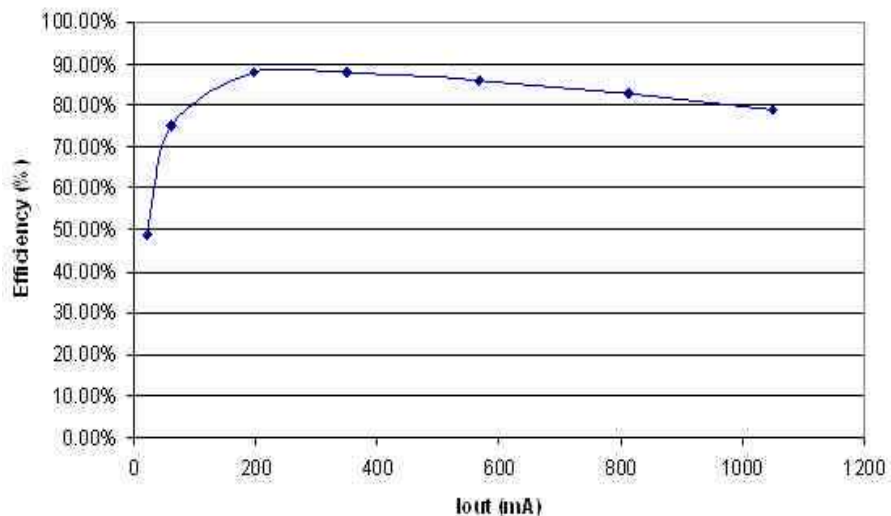


Fig. 12 - Efficiency

Typical Application(VOUT=1.2V)

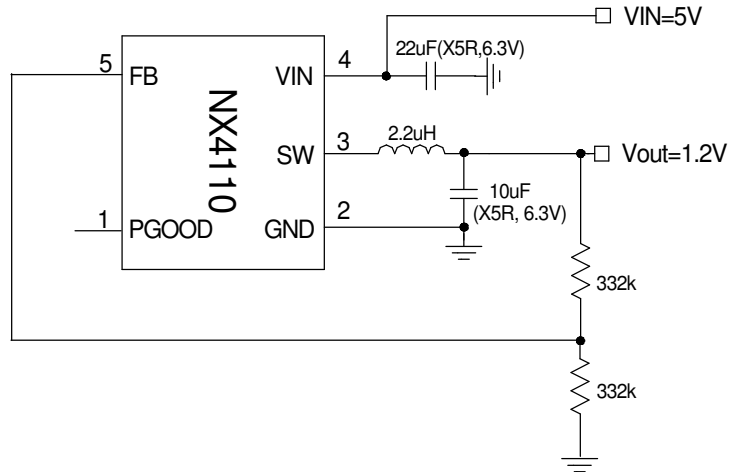


Fig. 13 - Demo board schematic

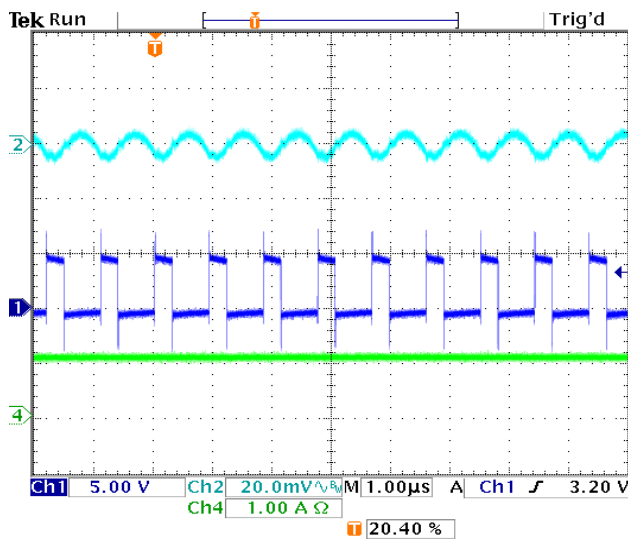


Fig. 14 - Output ripple

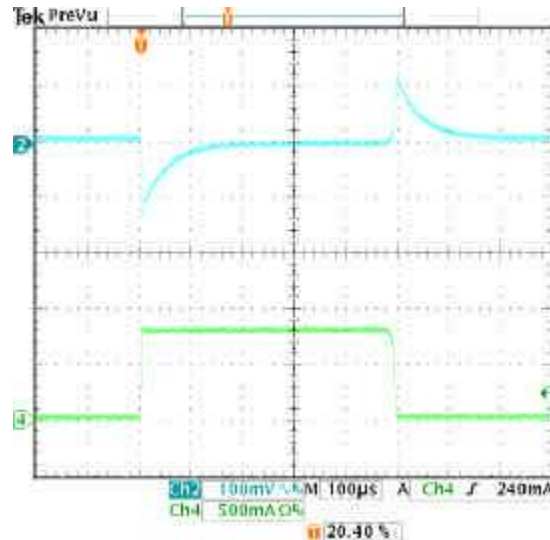


Fig. 15 - Transient response

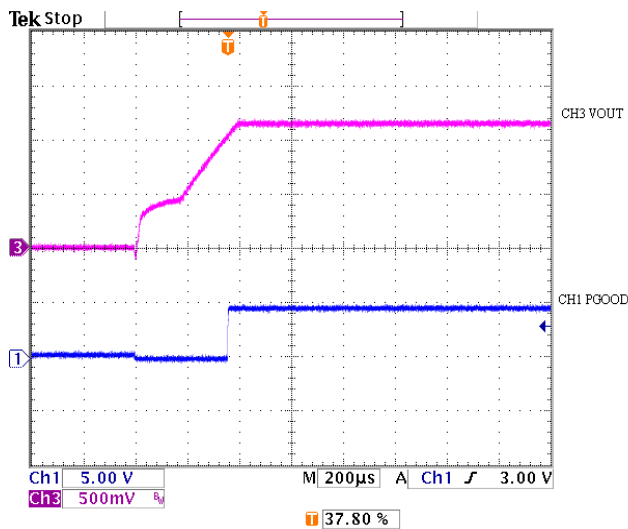


Fig. 16 - Startup

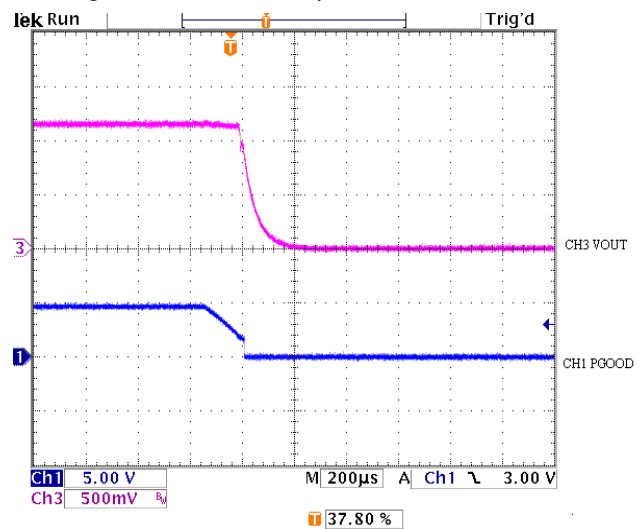


Fig. 17 - Shutdown

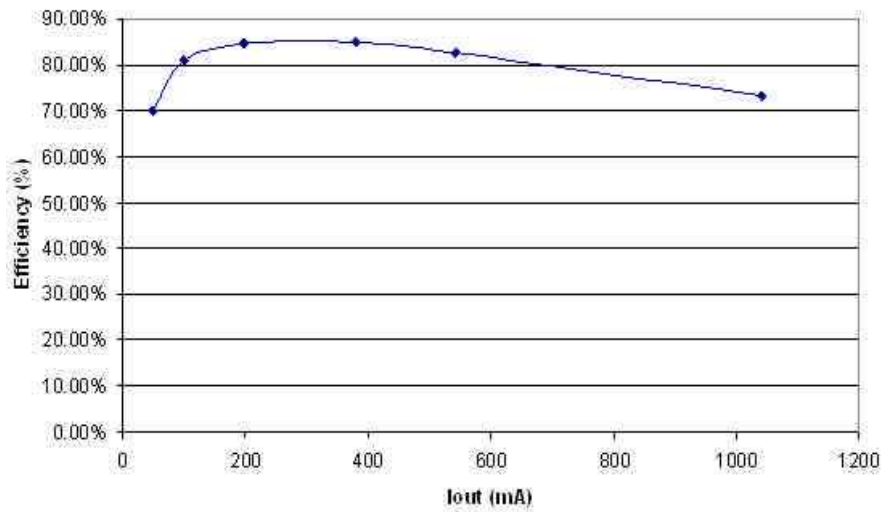
Typical Application(VOUT=1.2V)

Fig. 18 - Efficiency

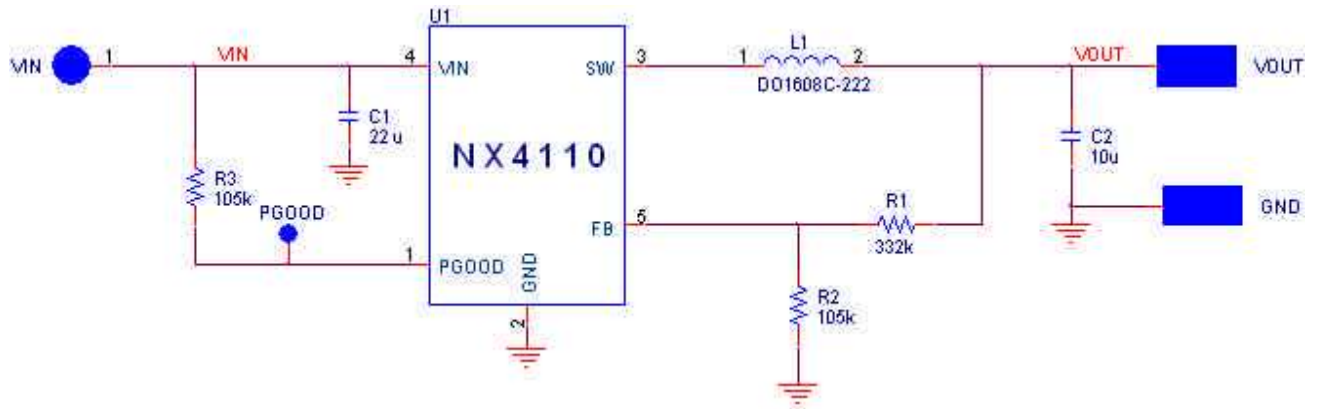
Demoboard Layout


Fig. 19 - Demoboard schematic

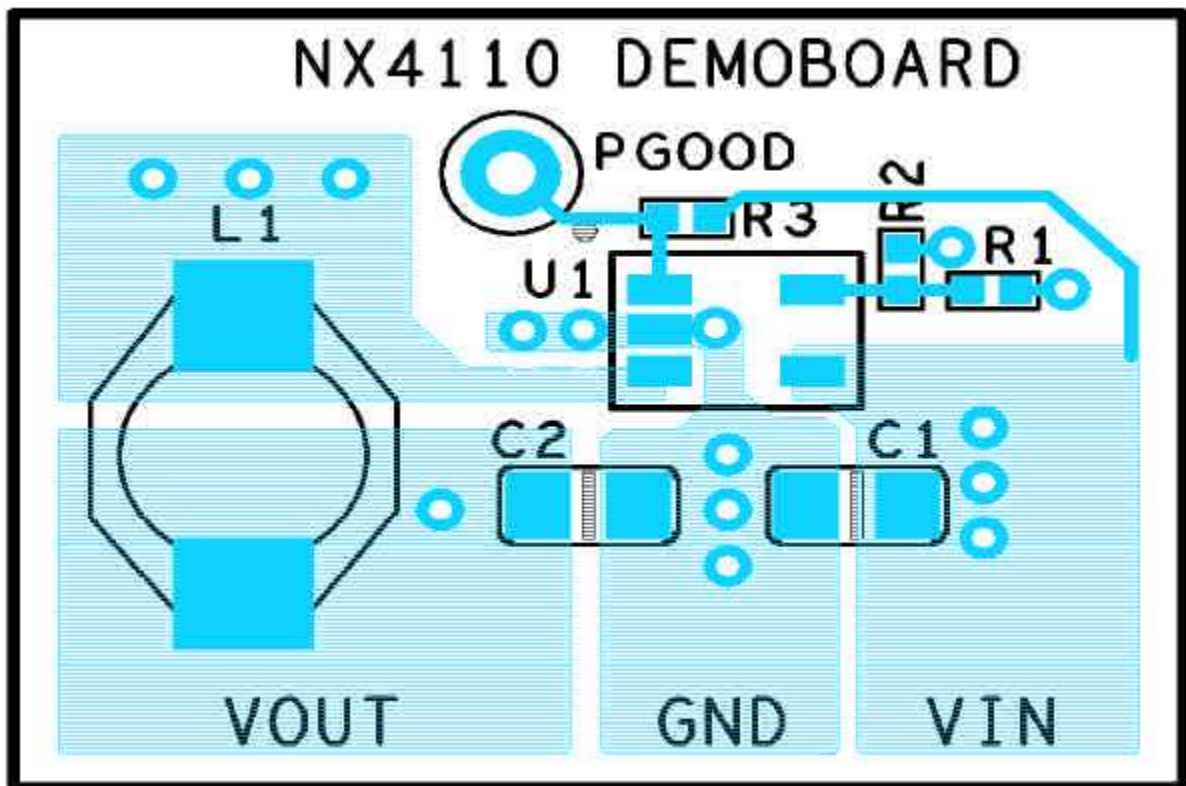


Fig. 20- Top layer

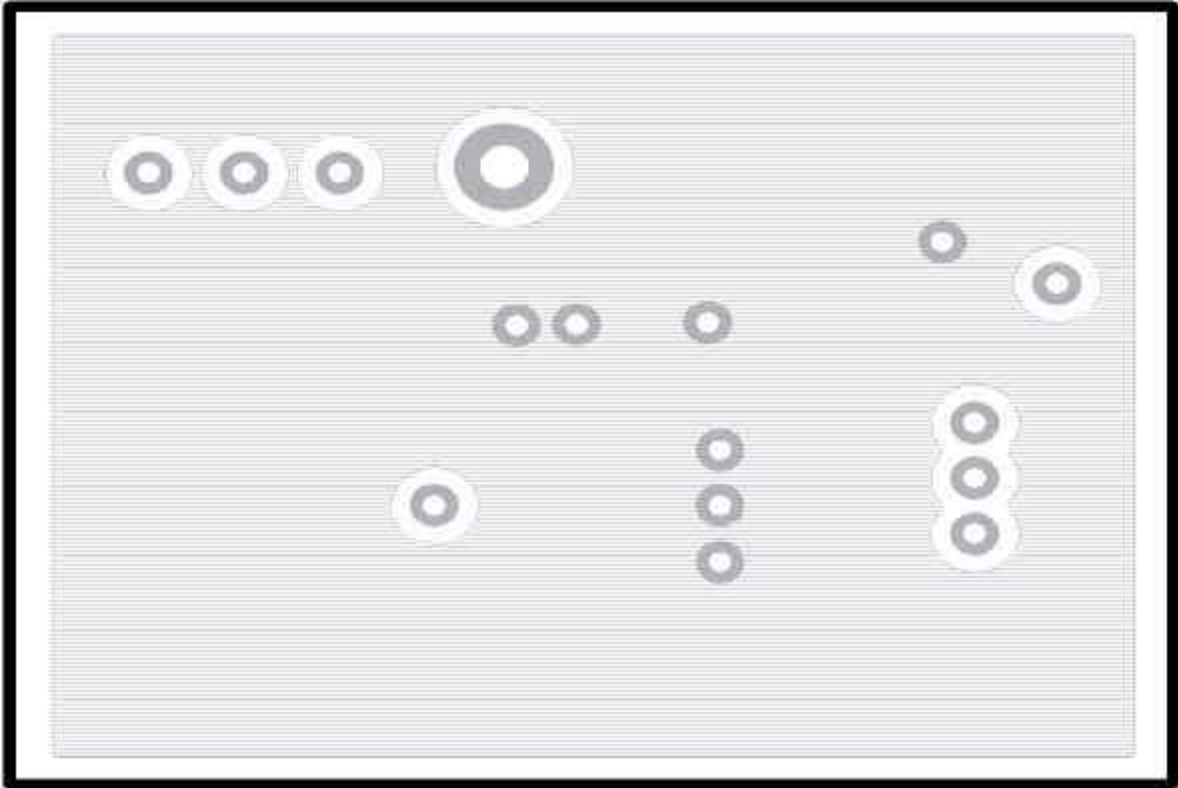


Fig. 21 - Gound layer

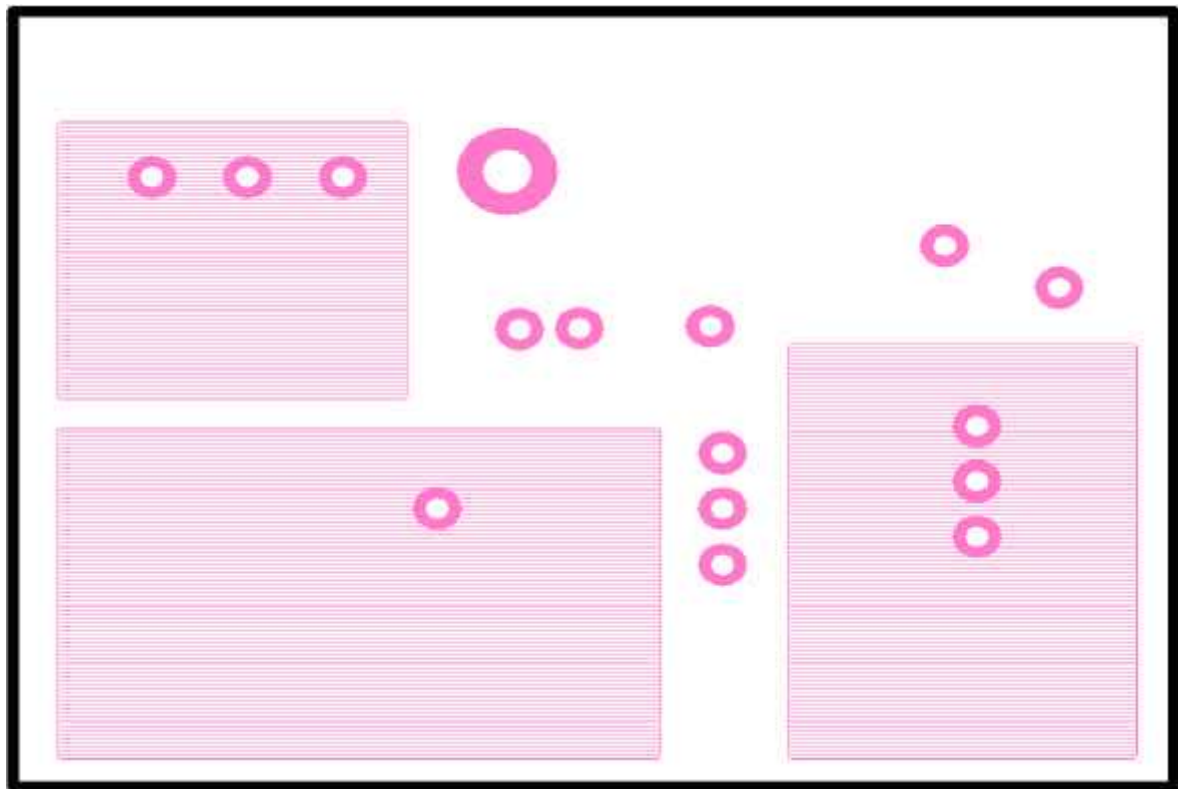


Fig. 22 - Power layer

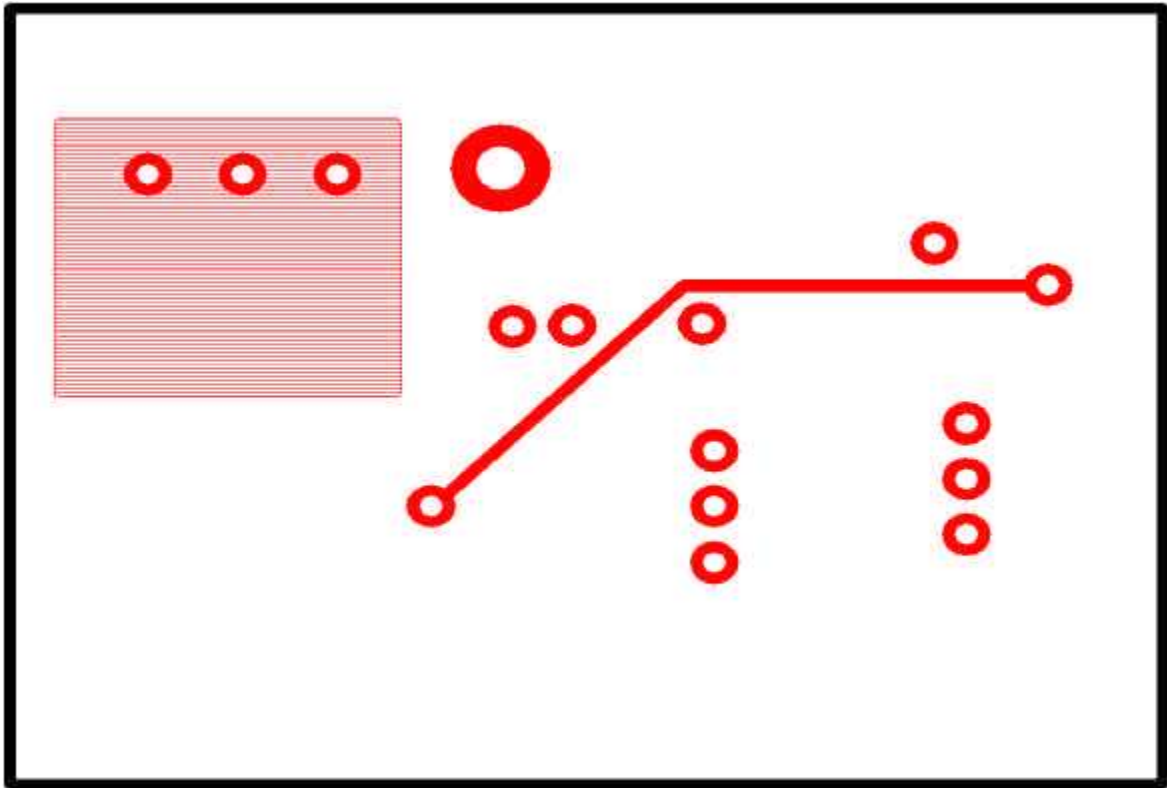
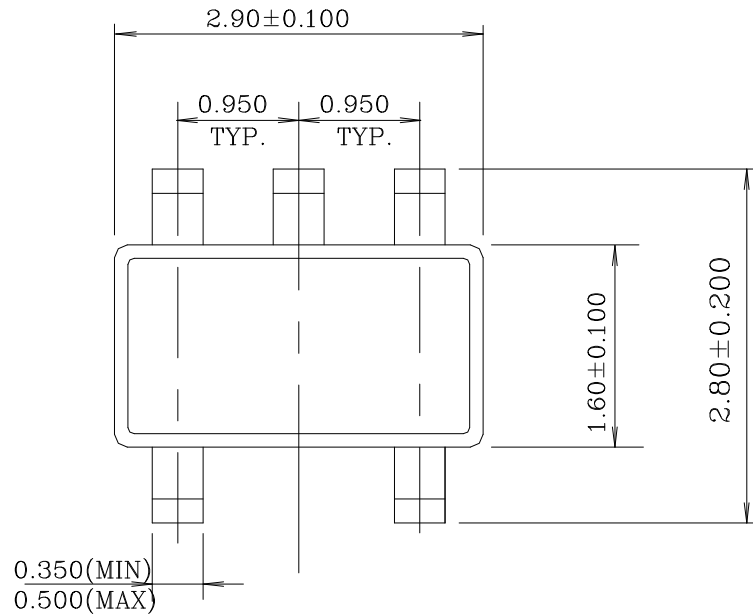
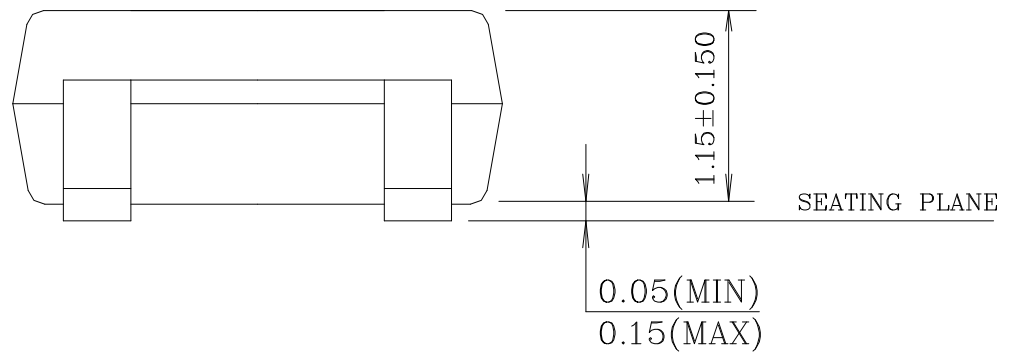


Fig. 23 - Bottom layer

SOT23 5 PIN PACKAGE OUTLINE DIMENSIONS

Top View



Side View