



15 Watt Sine Wave *Telephone Ring Generator* 15REN@86Vrms to 40REN@45Vrms



PCR-SIN15V48F00



15REN@86Vrms to 40REN@45Vrms SINE WAVE TELEPHONE RING GENERATOR

FEATURES

- ◆ Support 10-40 standard North American REN
- ◆ Adjustable Output Voltage between 45-100Vrms
- ◆ Overload Control with Constant Output Power
- ◆ Output Short Circuit Protection
- ◆ Digital Frequency Selection
- ◆ Zero Crossing Synchronization Output Signal
- ◆ Input Under/Over Voltage Protection
- ◆ High Output Load Indication Signal
- ◆ Low THD Sine Wave Output
- ◆ Fully Floating Output
- ◆ 90 Days Warranty
- ◆ UL1950, CSA C22.2 No. 950 and EN60950 Approved

APPLICATIONS

- ◆ PBX, PABX, DLC and Key Systems
- ◆ Rural Telephony Systems
- ◆ Wireless Local Loop Systems
- ◆ Satellite Telephone and VSAT Terminal
- ◆ Integrated Access Devices
- ◆ VoIP Gateways
- ◆ Short/Long Loop Applications
- ◆ Test Equipment

DESCRIPTION

The PCR-SIN15V48F00 Ring Generator offers high performance with an advanced overload protection mechanism. Each unit includes an internal crystal oscillator and supports all popular ringing frequencies of 16.7, 20, 25 and 50Hz. The PCR-SIN15V48F00 can continuously support up to 40 standard North American REN loads, providing a low THD sine wave ringing signal. The output ringing signal amplitude defaults to 86Vrms and can be externally adjusted to any value ranging between 45-100Vrms

Overload Protection

Loads that exceed the number of REN that the unit is set to support according to the preset output voltage, will momentarily clamp the output sine wave, and trigger the ring generator overload protection. This function allows the Ring Generator to provide continuous service to up to 40 North American REN loads. The overload protection constantly monitors the output distortion level, and will automatically reduce the output amplitude in order to maintain a low distortion level of THD≤5%. The new output amplitude will match the overload, according to the following table:

Output Ringing Amplitude	Load [1REN = 6930Ω+8μF]
100Vrms	10REN
90Vrms	13REN
86Vrms	15REN
75 Vrms	20REN
65 Vrms	25REN
55 Vrms	35REN
45 Vrms	40REN
Short Circuit Protection Active	>> 40REN

Output Short Circuit Protection

Loads that excessively exceed 40REN trigger an internal protection that monitors the unit's input current. When the input current threshold is exceeded for approximately 600mSec, the protection automatically shuts off the output. After the output has been off for 5 seconds, normal operation will automatically resume, depending on the existing load conditions.

TYPICAL APPLICATION 1

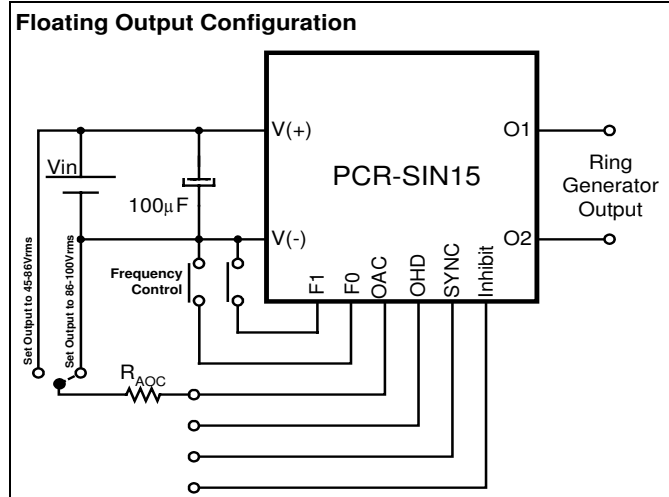

High Load Indication

The OHD output terminal provides indication of output High Load when the output power exceeds approximately 11 Watt. At High Load, the OHD terminal will provide an High 5V TTL Logic Level signal referenced to the V(-) terminal. This signal will remain at a High Level until the High Load condition is removed. This indication can be useful in order to keep the ring generator within a certain output voltage specifications by managing the output load.

Inhibit Control

The Inhibit terminal functions to shut down the output and reduce the unit's current consumption to an idling level. It is operated by 5V TTL logic levels referenced to the V(-) terminal. When this input is disconnected or tied to a TTL low level, the output is enabled. Negatively fed devices, where V(+) connects to the system's GND, and V(-) to negative 48Vdc, may require a few more components to match voltage levels between the telecom system's logic and the Inhibit control. Recommended connection is illustrated on INHIBIT CONTROL FOR NEGATIVE FED CONFIGURATION.

An internal synchronization circuitry activates a delay between the inhibit command and shuts off the unit until the sine wave output signal reaches the zero crossing. This assures that the output will always turn on and shut off at zero voltage. Note that the Inhibit control can be used to generate the ringing signal's on/off intervals. Inhibit control eliminates the need for additional external components in cadence implementation.

Output Amplitude Control

The output amplitude nominal value can be adjusted in the range of 45-100Vrms and defaults to 86Vrms @ 15 North American REN load, when the OAC terminal is left unconnected. Output amplitudes in the range of 86-100Vrms can be set by connecting an external resistor, R_{OAC}, between the OAC terminal and V(-). Output amplitudes in the range of 45-86Vrms can be set by connecting an external resistor, R_{OAC}, between the OAC terminal and V(+). For setting the R_{OAC} value, refer to the OUTPUT AMPLITUDE ADJUSTMENT graphs on page 24. Each output amplitude value is designed to support a certain nominal REN load according to the above table.



15REN@86Vrms to 40REN@45Vrms SINE WAVE TELEPHONE RING GENERATOR

PCR-SIN15V48F00

Zero Crossing Synchronization Output

The SYNC output provides a high TTL level pulse to indicate the AC output voltage zero crossing, relative to the output sine wave. This is useful for prolonging relay life by timing switching with the ringing signal zero crossing. The SYNC signal rises to a high TTL level, referenced to V(-), 2.5mSec prior to the zero crossing and remains at high level for about 5mSec. When the unit is set to a 50Hz ringing frequency, the SYNC signal rises to a high TTL level 2.0mSec prior to the zero crossing and remains at high level for 4mSec.

Output DC Biasing

The ring generator's output is isolated and floating and can be superimposed on negative or positive DC voltage. When the DC biasing option is utilized (see Typical Application 2), a series protection resistor should be added in to each port (i.e. telephone extension). This resistor should limit the potential DC current through the unit's output stage should the output be shorted. The recommended minimum values for these serial resistors are proportionate to the DC bias.

Output DC Bias	Series Protection Resistor
± 12Vdc	47Ω
± 24Vdc	100Ω
± 48Vdc	200Ω
± 75Vdc	350Ω

In the event that high frequency switching noise from the ring generator input reflects on the output via the Talk Battery line, a filter of a 22-100μF capacitor and a 10-20Ω resistor should be added. When the Inhibit terminal is enabled, no AC/DC voltage exists on the Ring Generator's output.

Input Voltage Supply

The PCR-SIN15V48F00 ring generator features a wide range of input voltage capabilities. These capabilities are achieved by utilizing a sophisticated feed forward topology, which continuously samples the input voltage. The units output amplitude is then regulated for line changes. Low frequency ripple on the input may be interpreted as line changes and reflect on the output. Therefore, it is essential to restrain the input's ripple. Acceptable levels are specified in the PERFORMANCE/FUNCTIONAL SPECIFICATIONS.

Connecting an input capacitor, as illustrated in the Typical Applications may reduce high frequency ripple on the input, which originates from the units internal 100kHz switching frequency.

Case Shielding

The SHIELD terminal is connected to the device's metal case. The terminal may be connected to grounded systems in order to reduce radiated EMI.

TYPICAL APPLICATION 2

Output AC is superimposed on DC bias – A single 48Vdc power supply is used for the Ring Generator feeding and for the output biasing

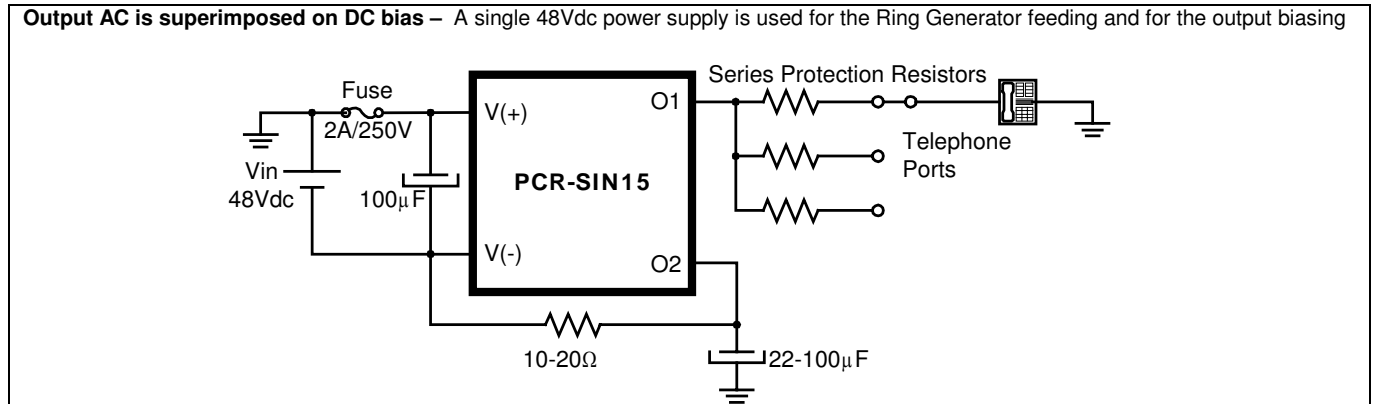

Note: A 0.1μF ceramic capacitor on each output line from the PCR-SIN15V48F00 Ring Generator prevents the possibility of the high switching frequencies causing interference down the line.

Output Frequency Control

Each PCR-SIN15V48F00 ring generator supports all four popular output frequencies: 16.7, 20, 25 and 50Hz. The frequency selection is controlled by TTL levels, referenced to V(-), or by jumpering the F0 and F1 control pins to the V(-), according to the following table:

Frequency	F1	F0
16.7Hz	"0" or tied to V(-)	"1" or disconnected
20Hz	"1" or disconnected	"1" or disconnected
25Hz	"1" or disconnected	"0" or tied to V(-)
50Hz	"0" or tied to V(-)	"0" or tied to V(-)

The F0 and F1 terminals are pulled up to an internal 5V source in reference to the V(-) terminal. For digital frequency control, use either an open collector or an opto-coupler driver. When utilizing digital frequency control or frequency setup jumpers that are connected via long conductors to the ring generator, the addition of two 47nF noise filtering capacitors between F0 and the V(-) and between the F1 and the V(-) terminals is advised.

Frequency changes take effect at start-up by power connection or by the Inhibit control. Frequency setup changes while the output is on may disturb normal operation.

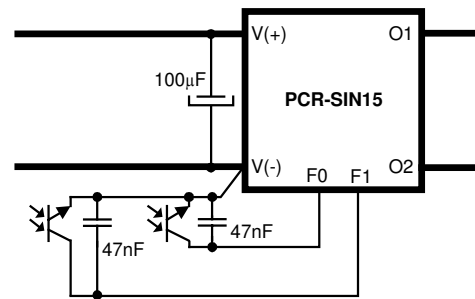



PCR-SIN15V48F00

15REN@86Vrms to 40REN@45Vrms SINE WAVE TELEPHONE RING GENERATOR

TYPICAL APPLICATION 3

Output AC is superimposed on DC bias – Two DC power supplies are used, one for the Ring Generator feeding and another for the output biasing

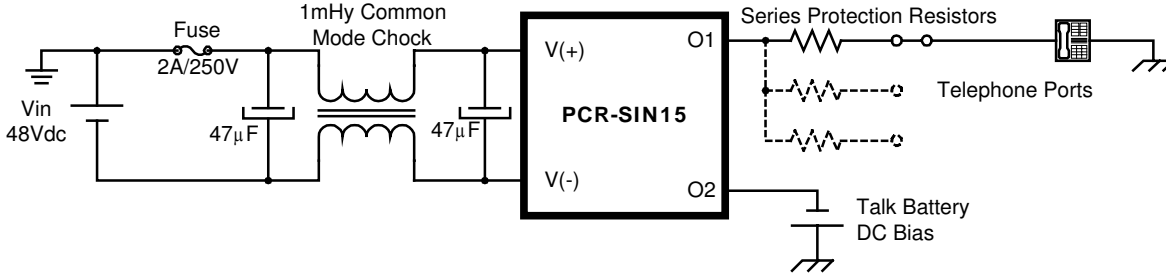

Note: A 0.1µF ceramic capacitor on each output line from the PCR-SIN15V48F00 Ring Generator prevents the possibility of the high switching frequencies causing interference down the line.

TEST SETUP

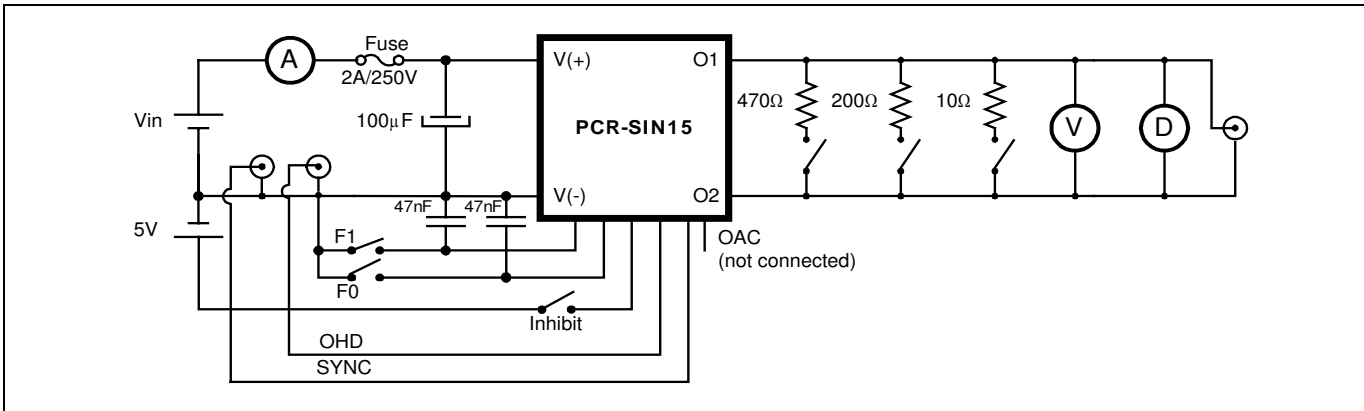

INHIBIT CONTROL FOR NEGATIVE FED CONFIGURATION

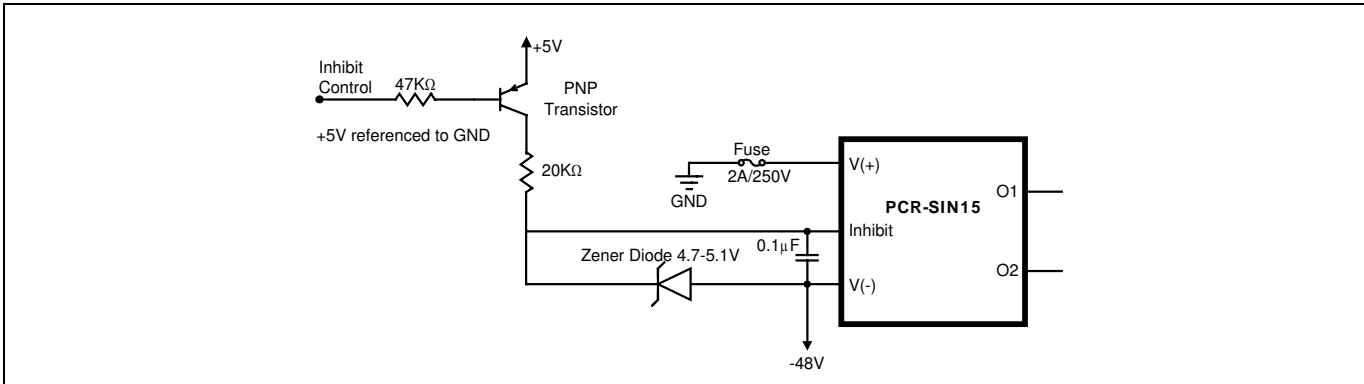

SAFETY INSTRUCTIONS

1. For North America, input voltage (nominal 48Vdc, tolerance 36-60Vdc) must be applied by an isolated DC source complying with the earthed SELV or TNV requirements of the UL1950, Third edition. For other countries, input voltage (nominal 48Vdc, tolerance 36-72Vdc) must be supplied by an isolated DC source complying with the earthed SELV or TNV requirements of the latest version of EN60950.
2. DC input must be protected by a UL Listed fuse rated maximum T2A, 250V (slow-blow 2A , 250V fuse).
3. When applicable, protection from excessive voltage on the output should be tested in end-use equipment.
4. For output voltage exceeding 80Vrms, compliance with the ringing signal requirements should be tested in end-use equipment. When the output voltage is set to less than 80Vrms, the ringing signal complies with M.2 requirements of IEC950.



PCR-SIN15V48F00
15REN@86Vrms to 40REN@45Vrms SINE WAVE TELEPHONE RING GENERATOR

ABSOLUTE MAXIMUM RATINGS*

Supply Voltage	+85V
Inhibit, F1 and F0 Input Voltage	-0.5V to +5.2V
Operating Ambient Temperature (T _A)	-40°C to +85°C
Storage Temperature	-55°C to +90°C
Lead Temperature (Soldering, 10 sec max.)	+300°C

*These are stress ratings. Exposure of the device to any of these conditions may adversely effect long-term reliability. Proper operation other than as specified in the PERFORMANCE / FUNCTIONAL SPECIFICATIONS is not implied.

PERFORMANCE / FUNCTIONAL SPECIFICATIONS

Typical at: T_A = +25°C, V_{in} = 48Vdc, Load=470Ω resistive, C_{in} = 100μF, OAC not connected, according to Test Setup schematics.

Parameters	Conditions	Min	Typ	Max	Units	
Supply						
Supply Voltage (V _{in})	100-120Hz, 36.0≤V _{in} ≤72.0, @ P _{out} =15VA	36.0	48.0	72.0	Vdc	
Supply Voltage Ripple				1.0	Vp-p	
Current Consumption						
Device Inhibited				60	4	mA
No Load					70	mA
Full Load	Load=470Ω, @ V _{in,min} =36V			750	mA	
Peak Current	Load≤470Ω, @ V _{in,min} =36V			1.4	A	
Input Under Voltage Protection		28.0		36.0	Vdc	
Input Over Voltage Protection		72.0		85.0	Vdc	
Efficiency	P _{out} = 15W	75	80		%	
Output						
Power	Continuous Loading	0		16	VA	
Power Factor		0.5			cos ρ	
Output Voltage	P _{out} =10VA					
OAC not connected	See graphs on OUTPUT AMPLITUDE ADJUSTMENT	80	86	92	Vrms	
R _{OAC} between OAC & V(+)/V(-)			45-100		Vrms	
Output Frequency	According to F0, F1 setting		16.7, 20, 25, 50		Hz	
Frequency Accuracy	36.0≤V _{in} ≤72.0Vdc, 0≤P _{out} ≤15W, -40°C ≤ T _A ≤+85°C			±3	%	
THD	40.0≤V _{in} ≤72.0Vdc, 0≤P _{out} ≤15W, -40°C ≤ T _A ≤+85°C			5	%	
Inhibit Control Input	Referenced to the V(-) Terminal					
Disable Voltage V _{IH}		3.5	5	5.2	Vdc	
Enable Voltage V _{IL}		-0.5	0	1.0	Vdc	
I _{in} Source	V _{IL} = 0V			700	μA	
I _{in} Sink	V _{IH} = 5V			700	μA	
F0, F1 Control Input	Referenced to the V(-) Terminal					
V _{IH}		3.5		5.2	Vdc	
V _{IL}		-0.5		1.0	Vdc	
I _{in} Source	V _{IL} = 0V			700	μA	
Inhibit Control Timing						
Time to Turn-On		40		50	ms	
Time to Turn-Off				35	ms	
Overload Protection Response						
Time to Turn-Off	Output Overloaded	200	600	800	ms	
Time to Turn-On	Load reverts to Normal; 0≤P _{out} ≤15VA		5		s	
General						
Insulation	500Vdc Input to Output	40			MΩ	
Switching Frequency			96		kHz	
Environment						
Relative Humidity	Non-Condensing, Per IEC 68-2-56			93	%	
Ambient Temperature (T _A)	Without Derating	-40		+50	°C	
	Derated from +50°C by 0.3W/°C			to +85	°C	
Reliability						
Calculated MTBF	Continuous Operation@40°C Ambient Temperature Calculation method: Relex Bellcore Software Ver5.30	4,000,000			Hours	
OHD, Sync Output	Referenced to V(-) Terminal					
V _{OH}	Output Source Current 2mA	4.2		5.3	Vdc	
V _{OL}	Output Sink Current 2mA	0		0.8	Vdc	
V _{OL}	Output Sink Current 5mA	0		1.2	Vdc	



15REN@86Vrms to 40REN@45Vrms SINE WAVE TELEPHONE RING GENERATOR

OUTPUT AMPLITUDE ADJUSTMENT

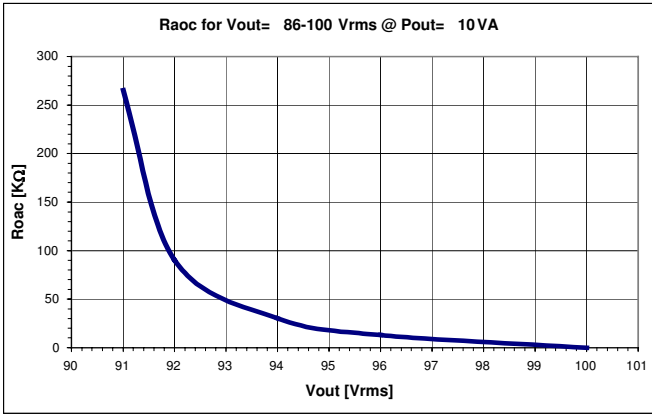

R_{OAC} connected between the OAC and the V(-) terminals

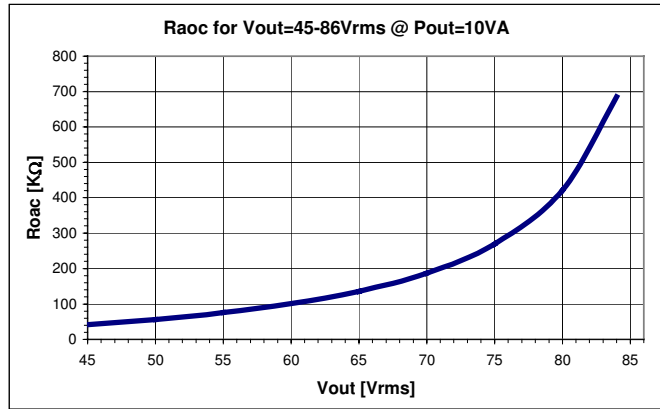

R_{OAC} connected between the OAC and the V(+) terminals

MECHANICAL DETAILS

DIMENSIONS

	mm	Inch
A	63.50±0.40	2.500"±0.016"
B	63.50±0.40	2.500"±0.016"
C	12.70 Max	0.500" Max
D	35.56±0.25	1.400"±0.01"
E	40.64±0.25	1.6000"±0.01"
F	35.56±0.25	1.400"±0.01"
G	0.64±0.10 SQ	0.025"±0.004 SQ
H	3.00±0.30	0.117"±0.012"
J	5.08±0.25	0.200"±0.01"
K	13.97±0.50	0.550"±0.02"
L	1.00±0.15	0.039"±0.005"

