

JTDA 150A

145 Watts, 36 Volts, Pulsed
Avionics 960 - 1215 MHz

GENERAL DESCRIPTION

The JTDA-150A is a high power COMMON BASE bipolar transistor. It is designed for pulsed systems in the frequency band 960-1215 MHz. The transistor includes input and output prematch for broadband performance. The device has gold thin-film metallization and diffused ballasting for proven highest MTTF. Low thermal resistance Solder Sealed Package reduces junction temperature, extends life.

CASE OUTLINE 55KT, STYLE 1

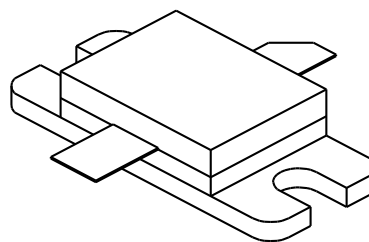

ABSOLUTE MAXIMUM RATINGS

Maximum Power Dissipation @ 25°C² 350 Watts

Maximum Voltage and Current

BVces Collector to Base Voltage 50 Volts
BVebo Emitter to Base Voltage 3.5 Volts
Ic Collector Current 15 Amps

Maximum Temperatures

Storage Temperature - 65 to + 200°C
Operating Junction Temperature + 200°C

ELECTRICAL CHARACTERISTICS @ 25 °C

SYMBOL	CHARACTERISTICS	TEST CONDITIONS	MIN	TYP	MAX	UNITS
Pout	Power Out	F = 960-1215 MHz	145			Watts
Pin	Power Input	Vcc = 36 Volts			24	Watts
Pg	Power Gain	PW = Note 1	8			dB
η_c	Collector Efficiency	DF = Note 1		45		%
VSWR	Load Mismatch Tolerance	F = 1215 MHz			3:1	

BVebo	Emitter to Base Breakdown	Ie = 20 mA	3.5			Volts
BVces	Collector to Emitter Breakdown	Ic = 60 mA	55			Volts
h_{FE}	DC - Current Gain	Ic = 5.0A, Vce = 5 V	20			
θ_{jc^2}	Thermal Resistance				0.5	°C/W

Note 1: JTIDS Pulse = 7 Micorseconds On / Off for 3.3 Millisec, 22 % Long term duty

2: At rated pulse conditions

Issue June 1996

GHz TECHNOLOGY INC. RESERVES THE RIGHT TO MAKE CHANGES WITHOUT FURTHER NOTICE. GHz RECOMMENDS THAT BEFORE THE PRODUCT(S) DESCRIBED HEREIN ARE WRITTEN INTO SPECIFICATIONS, OR USED IN CRITICAL APPLICATIONS, THAT THE PERFORMANCE CHARACTERISTICS BE VERIFIED BY CONTACTING THE FACTORY.

POWER OUTPUT vs FREQUENCY

Vcc = 36 V, Pin = 25 W

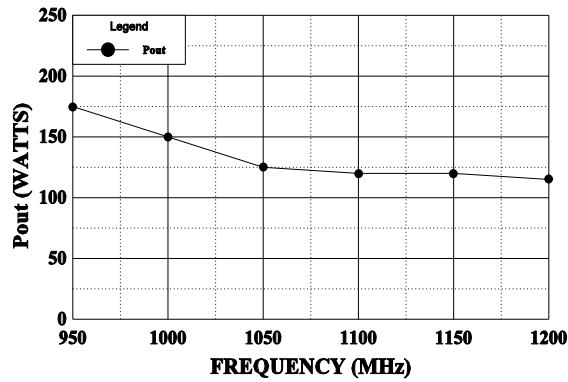

SERIES INPUT IMPEDANCE vs FREQUENCY

Vcc = 36 V, Po = 145 W

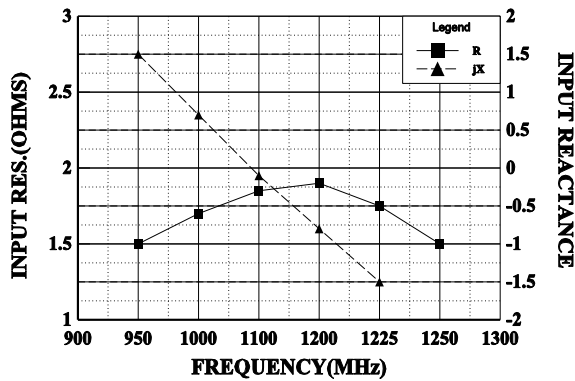

SERIES LOAD IMPEDANCE vs FREQUENCY

Vcc = 36 V, Po = 145 W

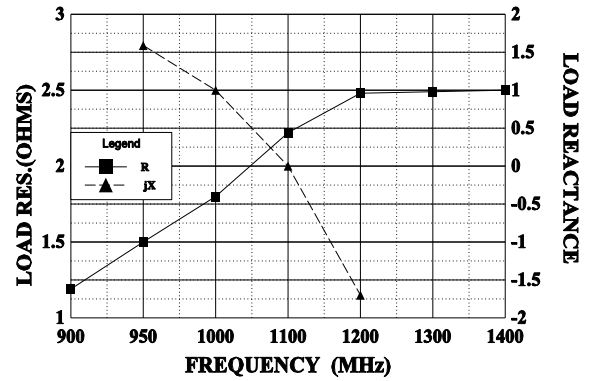

REVISIONS

ZONE	REV	DESCRIPTION	DATE	APPROVED
------	-----	-------------	------	----------

DIM	INCHES
A	.830
B	.940
C	.080
D	.515
E	.230
F	.026
G	.150
H	.300
I	.125
J	.090
K	.230
L	.300
M	.140
N	.230
O	.100
P	.200
Q	.200
R	.115
S	.025
T	.035
U	.160
V	.350
W	.240
X	.026

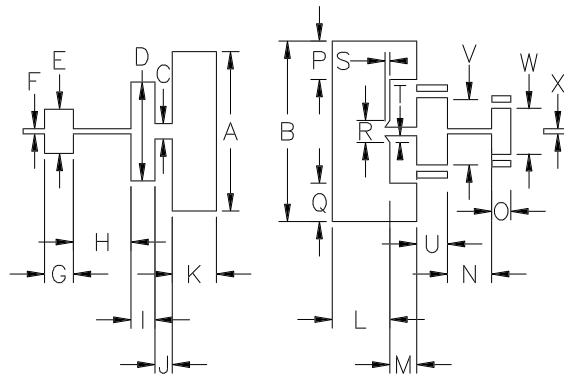

JTDA 150A TEST CIRCUIT

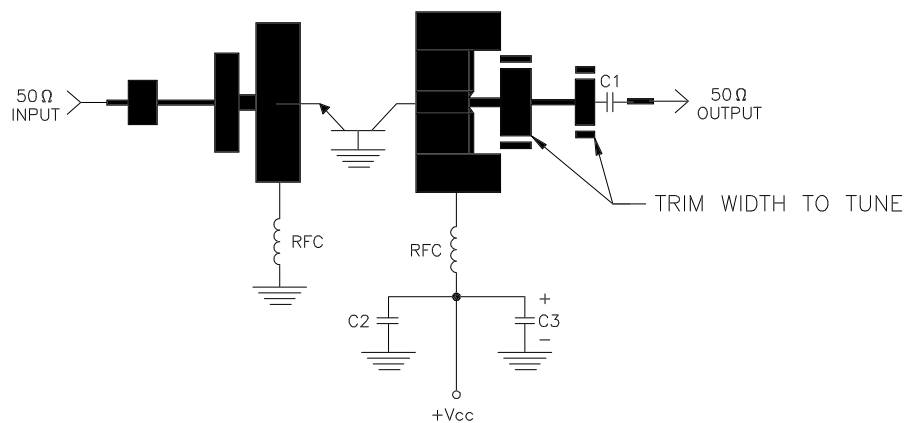

DIELECTRIC = ROGERS 6010
 Er = 10.2, t = 25
 C1, C2 = 82pF CHIP ATC "A"
 C3 = 1000 MFD @ 50V
 RFC = 5 turns #22 wire 1/16" I.D.