



**SG137A/SG237A/SG337A
SG137/SG237/SG337**

**1.5 AMP NEGATIVE
ADJUSTABLE REGULATOR**

DESCRIPTION

The SG137A family of negative adjustable regulators will deliver up to 1.5A output current over an output voltage range of -1.2V to -37V. Silicon General has made significant improvements in these regulators compared to previous devices, such as better line and load regulation, and a maximum output voltage error of 1%. The SG137 family uses the same chip design and guarantees maximum output voltage error of $\pm 2\%$.

Every effort has been made to make these devices easy to use and difficult to damage. Internal current and power limiting coupled with true thermal limiting prevents device damage due to overloads or shorts even if the regulator is not fastened to a heat sink.

The SG137A/137 family of products are ideal complements to the SG117A/117 adjustable positive regulators.

FEATURES

- 1 % output voltage tolerance
- 0.01%/V line regulation
- 0.5% load regulation
- 0.02%/W thermal regulation
- Available in hermetic TO-220

**HIGH RELIABILITY FEATURES
-SG137A/SG137**

- ◆ Available to MIL-STD-883 and DESC SMD
- ◆ Scheduled for MIL-M38510 QPL listing
- ◆ MIL-M38510/11804BYA - JAN137K
- ◆ LMI level "S" processing available

BLOCK DIAGRAM

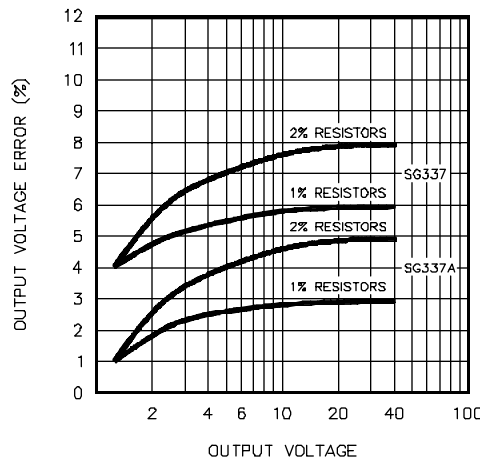
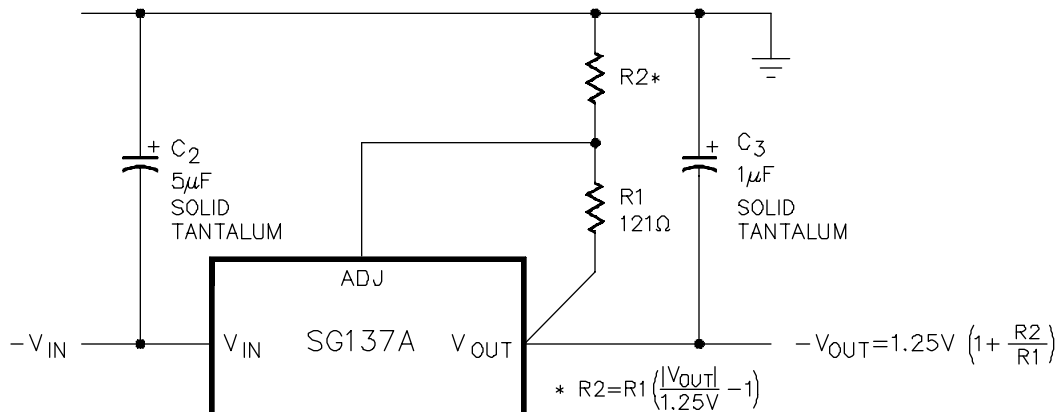

ABSOLUTE MAXIMUM RATINGS (Note 1)

Power DissipationInternally Limited
 Input to Output Voltage Differential40V
 Storage Temperature Range-65°C to 150°C

Operating Junction Temperature
 Hermetic (K, R, T, L, IG-Packages) 150°C
 Lead Temperature (Soldering, 10 Seconds) 300°C

Note 1. Exceeding these ratings could cause damage to the device.

THERMAL DATA

K Package:

Thermal Resistance-Junction to Leads, θ_{JC} 3.0°C/W
 Thermal Resistance-Junction to Ambient, θ_{JA} 35°C/W

R Package:

Thermal Resistance-Junction to Leads, θ_{JC} 5.0°C/W
 Thermal Resistance-Junction to Ambient, θ_{JA} 40°C/W

T Package:

Thermal Resistance-Junction to Leads, θ_{JC} 15°C/W
 Thermal Resistance-Junction to Ambient, θ_{JA} 120°C/W

IG Package:

Thermal Resistance-Junction to Leads, θ_{JC} 3.5°C/W
 Thermal Resistance-Junction to Ambient, θ_{JA} 42°C/W

L Package:

Thermal Resistance-Junction to Leads, θ_{JC} 35°C/W
 Thermal Resistance-Junction to Ambient, θ_{JA} 120°C/W

Note A. Junction Temperature Calculation: $T_J = T_A + (P_D \times \theta_{JA})$.

Note B. The above numbers for θ_{JC} are maximums for the limiting thermal resistance of the package in a standard mounting configuration. The θ_{JA} numbers are meant to be guidelines for the thermal performance of the device/pc-board system. All of the above assume no ambient airflow.

RECOMMENDED OPERATING CONDITIONS (Note 2 & 3)

Input Voltage Range-($V_{OUT} + 3.5V$) to -36V

Operating Junction Temperature Range

SG137A/SG137-55°C to 150°C
 SG237A/SG237:25°C to 150°C
 SG337A/SG337 0°C to 125°C

Note 2. Range over which the device is functional.

Note 3. These ratings are applicable for junction temperatures of less than 135°C.

ELECTRICAL CHARACTERISTICS

(Unless otherwise specified, these specifications apply over full operating ambient temperatures for SG137A/SG137 with $-55^\circ\text{C} \leq T_A \leq 150^\circ\text{C}$, SG237A/SG237 with $-25^\circ\text{C} \leq T_A \leq 150^\circ\text{C}$, SG337A/SG337 with $0^\circ\text{C} \leq T_A \leq 125^\circ\text{C}$, $|V_{IN} - V_{OUT}| = 5.0V$, and for $I_{OUT} = 500\text{mA}$ (K, R, and IG power packages) and $I_{OUT} = 100\text{mA}$ (T and L packages). Although power dissipation is internally limited, these specifications are applicable for power dissipations of 2Ω for the T and L packages, and 20Ω for the K, R, and IG packages. I_{MAX} is 1.5A for the K, R, and IG packages and 0.5A for the T and L packages. Low duty cycle pulse testing techniques are used which maintains junction and case temperatures equal to the ambient temperature.)

Parameter	Test Conditions	SG137A/SG237A			SG137/SG237			Units
		Min.	Typ.	Max.	Min.	Typ.	Max.	
Reference Voltage (Note 6)	$I_{OUT} = 10\text{mA}$, $T_A = 25^\circ\text{C}$	-1.238	-1.250	-1.262	-1.225	-1.250	-1.275	V
	$3V \leq V_{IN} - V_{OUT} \leq 40V$, $10\text{mA} \leq I_{OUT} \leq I_{MAX}$	-1.220	-1.250	-1.280	-1.200	-1.250	-1.300	V
Line Regulation (Note 4, 6)	$3V \leq V_{IN} - V_{OUT} \leq 40V$, $I_{OUT} \leq I_{MAX}$ $T_A = 25^\circ\text{C}$		0.005	0.01		0.01	0.02	%/V
Load Regulation (Note 4)	$10\text{mA} \leq I_{OUT} \leq I_{MAX}$ $ V_{OUT} \leq 5V$, $T_A = 25^\circ\text{C}$		5	25		15	25	mV
	$ V_{OUT} \geq 5V$, $T_A = 25^\circ\text{C}$		0.1	0.5		0.3	0.5	%
	$ V_{OUT} \leq 5V$		10	50		20	50	mV
	$ V_{OUT} \geq 5V$		0.2	1.0		0.3	1.0	%
Thermal Regulation (Note 5)	$T_A = 25^\circ\text{C}$, 10ms pulse		0.002	0.02		0.002	0.02	%/W
Ripple Rejection	$V_{OUT} = -10V$, $f = 120\text{Hz}$ $C_{ADJ} = 0$, $T_A = 25^\circ\text{C}$	60	66			60		dB
	$C_{ADJ} = 10\mu\text{F}$	70	80		66	77		dB
Adjust Pin Current	$T_A = 25^\circ\text{C}$		65	100		65	100	μA
Adjust Pin Current Change (Note 6)	$3V \leq V_{IN} - V_{OUT} \leq 40V$ $10\text{mA} \leq I_{OUT} \leq I_{MAX}$		1.0	5		2	5	μA
			0.2	2		0.5	5	μA

ELECTRICAL CHARACTERISTICS (continued)

Parameter	Test Conditions	SG137A/SG237A			SG137/SG237			Units
		Min.	Typ.	Max.	Min.	Typ.	Max.	
Minimum Load Current	$ V_{IN} - V_{OUT} \leq 40V$		2.5	5.0		2.5	5.0	mA
	$ V_{IN} - V_{OUT} \leq 10V$		1.2	3		1.2	3.0	mA
Current Limit	$ V_{IN} - V_{OUT} \leq 15V$							
	K, P, R, IG Packages	1.5	2.2	3.2	1.5	2.2		A
	T, L, Packages	0.5	0.8	1.5	0.5	0.8		A
	$ V_{IN} - V_{OUT} \leq 40V, T_J = 25^\circ C$							
	K, P, R, IG Packages	0.24	0.4	1.0	0.24	0.4		A
	T, L, Packages	0.15	0.25	0.5	0.15	0.25		A
Temperature Stability (Note 5)			0.6	1.5		0.6		%
Long Term Stability (Note 5)	$T_A = 125^\circ C, 1000 \text{ Hours}$		0.3	1.0		0.3	1.0	%
RMS Output Noise (% of V_{OUT})	$T_A = 25^\circ C, 10Hz \leq f \leq 10 \text{ KHz}$ (Note 5)		0.003			0.003		%

Parameter	Test Conditions	SG337A			SG337			Units
		Min.	Typ.	Max.	Min.	Typ.	Max.	
Reference Voltage (Note 6)	$I_{OUT} = 10mA, T_A = 25^\circ C$	-1.238	-1.250	-1.262	-1.213	-1.250	-1.287	V
	$3V \leq V_{IN} - V_{OUT} \leq 40V, 10mA \leq I_{OUT} \leq I_{MAX}$	-1.220	-1.250	-1.280	-1.200	-1.250	-1.300	V
Line Regulation (Note 4, 6)	$3V \leq V_{IN} - V_{OUT} \leq 40V, I_{OUT} \leq I_{MAX}$ $T_A = 25^\circ C$		0.005	0.01		0.01	0.04	%/V
Load Regulation (Note 4)	$10mA \leq I_{OUT} \leq I_{MAX}$							
	$ V_{OUT} \leq 5V, T_A = 25^\circ C$		5	25		15	50	mV
	$ V_{OUT} \geq 5V, T_A = 25^\circ C$		0.1	0.5		0.3	1.0	%
	$ V_{OUT} \leq 5V$		10	50		20	70	mV
	$ V_{OUT} \geq 5V$		0.2	1.0		0.3	1.5	%
Thermal Regulation (Note 5)	$T_A = 25^\circ C, 10ms \text{ pulse}$		0.002	0.02		0.003	0.04	%/W
Ripple Rejection	$V_{OUT} = -10V, f = 120Hz$							
	$C_{ADJ} = 0, T_A = 25^\circ C$	60	66			60		dB
	$C_{ADJ} = 10\mu F$	70	80		66	77		dB
Adjust Pin Current	$T_A = 25^\circ C$		65	100		65	100	μA
Adjust Pin Current Change (Note 6)	$3V \leq V_{IN} - V_{OUT} \leq 40V$		1.0	5		2	5	μA
	$10mA \leq I_{OUT} \leq I_{MAX}$		0.2	2		0.5	5	μA
Minimum Load Current	$ V_{IN} - V_{OUT} \leq 40V$		2.5	5		2.5	10	mA
	$ V_{IN} - V_{OUT} \leq 10V$		1.2	3		1	6	mA
Current Limit	$ V_{IN} - V_{OUT} \leq 15V$							
	K, P, R, IG-Packages	1.5	2.2	3.5	1.5	2.2		A
	T, L-Packages	0.5	0.8	1.5	0.5	0.8		A
	$ V_{IN} - V_{OUT} \leq 40V, T_J = 25^\circ C$							
	K, P, R, IG- Packages	0.24	0.5	1.0	0.15	0.4		A
	T, L-Packages	0.15	0.25	0.5	0.10	0.17		A
Temperature Stability (Note 5)			0.6	1.5		0.6		%
Long Term Stability (Note 5)	$T_A = 125^\circ C, 1000hr$		0.3	1.0		0.3	1.0	%
RMS Output Noise (% of V_{OUT})	$T_A = 25^\circ C, 10Hz \leq f \leq 10KHz$ (Note 5)		0.003			0.003		%

Note 4. Regulation is measured at constant junction temperature, using pulse testing with a low duty cycle. Changes in output voltage due to heating effects are covered under the specification for thermal regulation.

Note 5. These parameters, although guaranteed, are not tested in production.

Note 6. I_{MAX} for K, R, and IG packages is $V_{IN} - V_{OUT} = 3V / 1.5A$ and $V_{IN} - V_{OUT} = 40V / 240mA$. For T and L packages I_{MAX} is $V_{IN} - V_{OUT} = 3V / 500mA$ and $V_{IN} - V_{OUT} = 40V / 150mA$.

CHARACTERISTIC CURVES

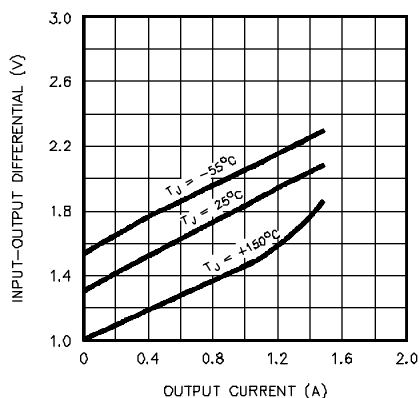

FIGURE 1.
INPUT/OUTPUT DIFFERENTIAL
VS. OUTPUT CURRENT

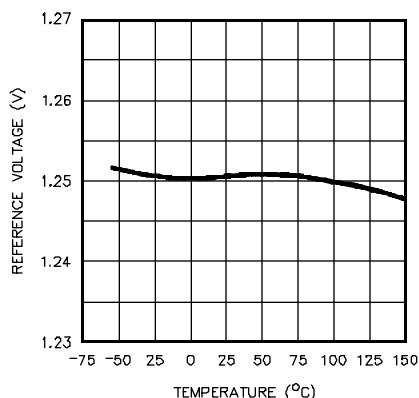

FIGURE 2.
REFERENCE VOLTAGE VS. TEMPERATURE

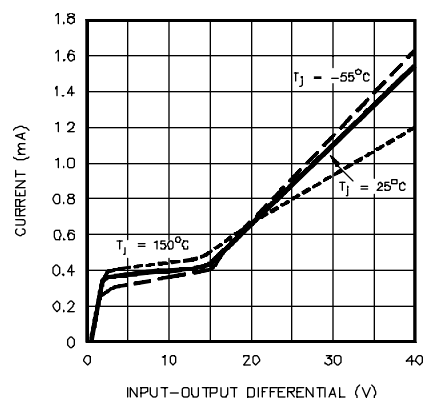

FIGURE 3.
CURRENT VS. INPUT/OUTPUT DIFFERENTIAL

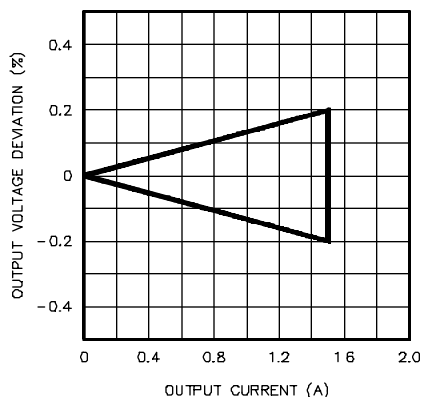

FIGURE 4. *
OUTPUT VOLTAGE DEVIATION
VS. OUTPUT CURRENT

* The SG137A has load regulation compensation which makes the typical unit read close to zero. This band represents the typical production spread.

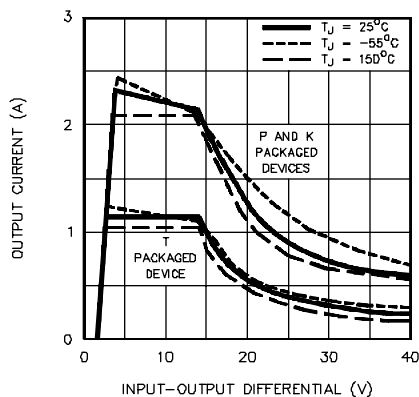

FIGURE 5.
INPUT/OUTPUT DIFFERENTIAL
VS. OUTPUT CURRENT

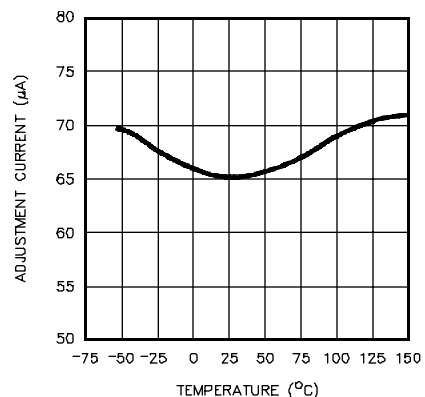

FIGURE 6.
ADJUSTMENT CURRENT VS. TEMPERATURE

APPLICATION INFORMATION

OUTPUT VOLTAGE

The output voltage is determined by two external resistors, R_1 & R_2 (see Figure 7).

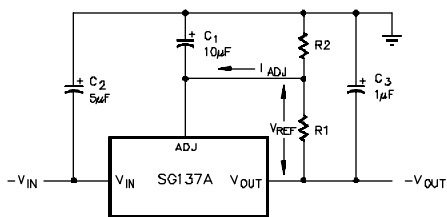

FIGURE 6

The exact formula for the output voltage is:

$$V_{OUT} = V_{REF} \left(\frac{R_2 + R_1}{R_1} \right) + I_{ADJ} (R_2)$$

Where: V_{REF} = Reference Voltage, I_{ADJ} = Adjustment Pin Current. In most applications, the second term is small enough to be ignored, typically about 0.5% of V_{OUT} . In more critical applications, the exact formula should be used, with I_{ADJ} equal to 65µA. Solving for R_2 yields:

$$R_2 = \frac{V_{OUT} - V_{REF}}{\frac{V_{REF}}{R_1} + I_{ADJ}}$$

Smaller values of R_1 and R_2 will reduce the influence of I_{ADJ} on the output voltage, but the no-load current drain on the regulator will be increased. Typical values for R_1 are between 100Ω and 300Ω, giving 12.5 mA and 4.2mA no-load current respectively. There is an additional consideration in selecting R_1 the minimum load current specification of the regulator. The operating current of

APPLICATION INFORMATION (continued)

the SG137A flows from input to output. If this current is not absorbed by the load, the output of the regulator will rise above the regulated value. The current drawn by R_1 and R_2 is normally high enough to absorb the current, but care must be taken in no-load situations where R_1 and R_2 have high values. The maximum value for the operating current, which must be absorbed, is 5mA for the SG137A. If input-output voltage differential is less than 10V, the operating current that must be absorbed drops to 3mA. The output stability, load regulation, line regulation, thermal

EXAMPLES:

1. A precision 10V regulator to supply up to 1Amp load current.
 - a. Select $R_1 = 100\Omega$ to minimize effect of I_{ADJ}
 - b. Calculate $R_2 = \frac{V_{OUT} - V_{REF}}{(V_{REF}/R_1) + I_{ADJ}} = \frac{10V - 1.25V}{(1.25V/100W) + 65mA} = 704W$
2. A 15V regulator to run off batteries and supply 50mA. $V_{IN MAX} = 25V$
 - a. To minimize battery drain, select R_1 as high as possible

$$R_1 = \frac{1.25V}{3mA} = 417\Omega, \text{ use } 404\Omega, 1\%$$

TYPICAL APPLICATIONS

regulation, temperature drift, long term drift, and noise, can be improved by a factor of 6.6 over the standard regulator configuration. This assumes a zener whose drift and noise is considerably better than the regulator itself. The LM329B has 20PPM/°C maximum drift and about 10 times lower noise than the regulator.

In the application shown Figure 8, regulators #2 to #N will track regulator #1 to within $\pm 24mV$ initially, and to $\pm 60mV$ over all load, line, and temperature conditions. If any regulator output is shorted to ground, all other outputs will drop to -2V. Load regulation of regulators #2 to #N will be improved by $V_{OUT}/1.25V$ compared to a standard regulator, so regulator #1 should be the one which has the lowest load current.

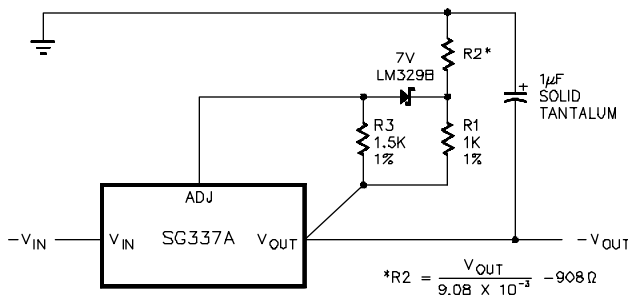

FIGURE 9 - HIGH STABILITY REGULATOR

$$*R2 = \frac{V_{OUT}}{9.08 \times 10^{-3}} = 908\Omega$$

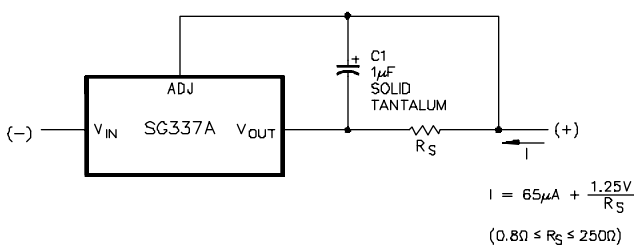

FIGURE 10 - CURRENT REGULATOR

$$I = 65\mu A + \frac{1.25V}{R_S}$$

($0.8\Omega \leq R_S \leq 250\Omega$)

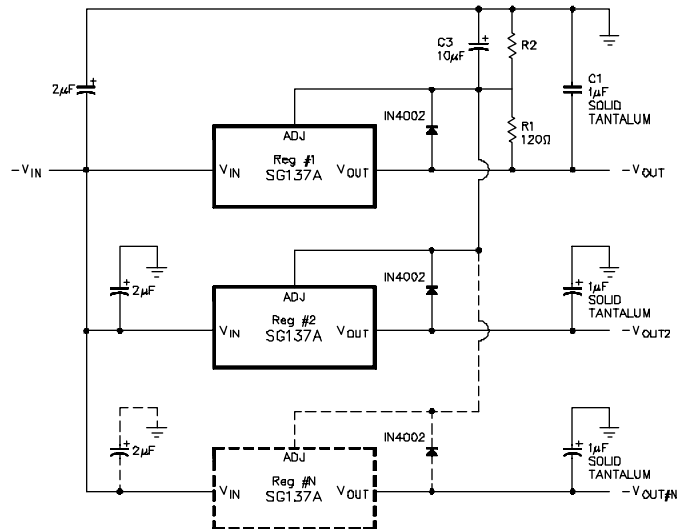

FIGURE 8 - MULTIPLE TRACKING REGULATORS

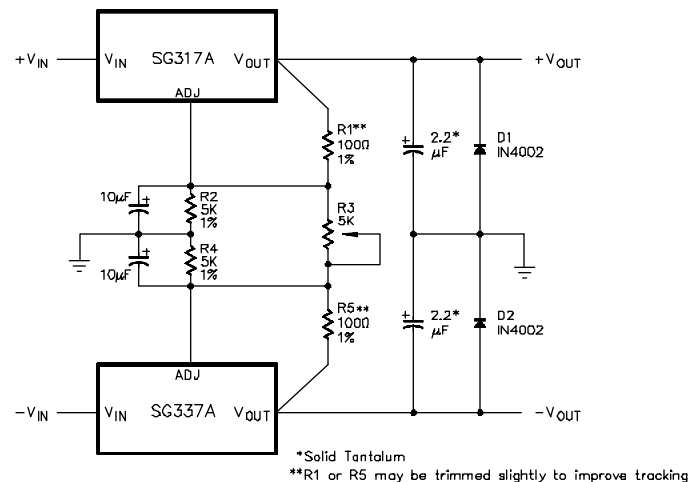

FIGURE 11 - DUAL TRACKING SUPPLY $\pm 1.25V$ to $\pm 20V$

*Solid Tantalum
**R1 or R5 may be trimmed slightly to improve tracking

CONNECTION DIAGRAMS & ORDERING INFORMATION (See Notes Below)

Package	Part No.	Ambient Temperature Range	Connection Diagram
3-TERMINAL TO-3 METAL CAN K-PACKAGE	SG137AK/883B	-55°C to 125°C	
	SG137AK/DESC	-55°C to 125°C	
	SG137AK	-55°C to 125°C	
	SG237AK	-25°C to 85°C	
	SG337AK	0°C to 70°C	
	SG137K/883B	-55°C to 125°C	
	JAN137K	-55°C to 125°C	
	SG137K/DESC	-55°C to 125°C	
	SG137K	-55°C to 125°C	
	SG237K	-25°C to 85°C	
SG337K	0°C to 70°C		
3-TERMINAL TO-66 METAL CAN R-PACKAGE	SG137AR/883B	-55°C to 125°C	
	SG137AR/DESC	-55°C to 125°C	
	SG137AR	-55°C to 125°C	
	SG237AR	-25°C to 85°C	
	SG337AR	0°C to 70°C	
	SG137R/883B	-55°C to 125°C	
	SG137R/DESC	-55°C to 125°C	
	SG137R	-55°C to 125°C	
	SG237R	-25°C to 85°C	
	SG337R	0°C to 70°C	
3-PIN TO-39 METAL CAN T-PACKAGE	SG137AT/883B	-55°C to 125°C	
	SG137AT/DESC	-55°C to 125°C	
	SG137AT	-55°C to 125°C	
	SG237AT	-25°C to 85°C	
	SG337AT	0°C to 70°C	
	SG137T/883B	-55°C to 125°C	
	SG137T/DESC	-55°C to 125°C	
	SG137T	-55°C to 125°C	
	SG237T	-25°C to 85°C	
	SG337T	0°C to 70°C	
3-PIN HERMETIC TO-257 IG-PACKAGE (Isolated)	SG137AIG/883B	-55°C to 125°C	
	SG137AIG/DESC	-55°C to 125°C	
	SG137AIG	-55°C to 125°C	
	SG137IG/883B	-55°C to 125°C	
	SG137IGDESC	-55°C to 125°C	
	SG137IG	-55°C to 125°C	
20-PIN CERAMIC (LCC) LEADLESS CHIP CARRIER L-PACKAGE	SG137AL/883B	-55°C to 125°C	<p>(Note 4)</p>
	SG137AL/DESC	-55°C to 125°C	
	SG137AL	-55°C to 125°C	
	SG137L/883B	-55°C to 125°C	
	SG137L/DESC	-55°C to 125°C	
	SG137L	-55°C to 125°C	

Note 1. Contact factory for JAN and DESC product availability.
 2. All parts are viewed from the top.

3. Product is also available in flatpack. Consult factory for price and delivery.
 4. Both outputs must be externally connected together at the device terminals.