

DESCRIPTION

The LX7104 is a 1.4MHz fixed frequency, current mode, PWM buck (step-down) DC-DC converter, capable of driving a 1.5A load with high efficiency, excellent line and load regulation. The device integrates a N-channel power MOSFET switch with low on-resistance. The converter accepts a wide input voltage range from 4.5V to 18V, and provides an output voltage adjustable typically from 0.81 to 15V.

Soft-start is built in, and current mode control provides fast transient response and cycle-by-cycle current limit. Short circuit protection will be triggered when current is over limit and FB is below 0.25V.

The LX7104ISF is available in SOT23-6 package.

KEY FEATURES

- Input Supply Range: 4.5V to 18V
- Output Voltage Adjustable from 0.81V to 15V
- Integrated High-Side NMOS Switch
- Current Mode Control
- Output Current: 1.5A
- Fixed 1.4MHz Frequency
- High Efficiency: Up To 92%
- Built-in Soft-start
- Built-in OV, UV & OT Protection
- Cycle-by-cycle Over Current Protection
- Short Circuit Protection
- RoHS Compliant & Halogen Free

APPLICATIONS

- LCD TV's / Monitor
- DPF
- Portable DVD

IMPORTANT: For the most current data, consult MICROSEMI's website: <http://www.microsemi.com>

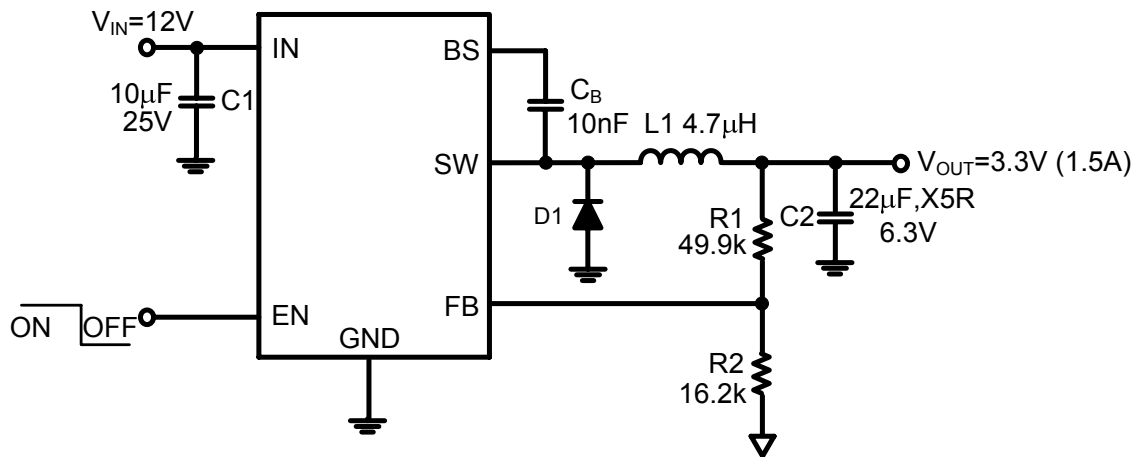
PRODUCT HIGHLIGHT

Typical Application

PACKAGE ORDER INFO
THERMAL DATA

T_A (°C)	SF	Plastic SOT23-6	$\theta_{JA} = 220 \text{ }^\circ\text{C/W}$
		RoHS Compliant / Pb-free	THERMAL RESISTANCE-JUNCTION TO AMBIENT
-40 to +85		LX7104ISF	Junction Temperature Calculation: $T_J = T_A + (P_D \times \theta_{JA})$. The θ_{JA} numbers are guidelines for the thermal performance of the device/pc-board system. All of the above assume no ambient airflow. θ_{JA} number above is with 4-layer pcb board.
Note: Available in Tape & Reel. Append the letters "TR" to the part number. (i.e. LX7104ISF-TR)			

ABSOLUTE MAXIMUM RATINGS

IN (Input Pin).....	-0.3V to 20V
EN (Enable Pin).....	-0.3V to $V_{IN}+0.3V$
SW (Switch Pin).....	21V
BS (Bootstrap Pin).....	-0.3V to $V_{SW}+6V$
FB (Feedback Pin).....	-0.3V to 6V
Maximum Junction Temperature.....	150°C
Storage Temperature Range.....	-65°C to 150°C
Lead Temperature. (Soldering 10 seconds).....	260°C

Notes: Exceeding these ratings could cause damage to the device. All voltages are with respect to GND. Currents are positive into, negative out of specified terminal. These are stress ratings only and functional operation of the device at these or any other conditions beyond those indicated under "Recommended Operating Conditions" are not implied. Exposure to "Absolute Maximum Ratings" for extended periods may affect device reliability.

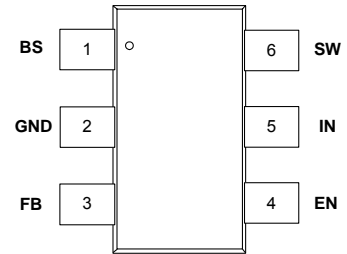
PACKAGE PIN OUT

LX7104
SF PACKAGE
(Top View)

RoHS / Pb-free Matte Tin Pin Finish

RECOMMENDED OPERATING CONDITIONS

Parameters	Symbol	Min	Max	Units
Input Voltage	V_{IN}	4.5	18	V
Maximum Output Current	$I_{OUT} (MAX)$	1.5		A
Operating Ambient Temperature	T_A	-40	85	°C

ELECTRICAL CHARACTERISTICS

$V_{IN} = V_{EN} = 12V$, $V_{OUT} = 3.3V$, $T_A = 25^\circ C$, unless otherwise specified.

Parameters	Symbol	Test Conditions/Comments	MIN	TYP	MAX	Units
Recommended Operating Range						
V_{IN}	V_{IN}		4.5		18	V
Operating Current						
Quiescent Current	I_Q	$V_{FB} = 0.9V$		0.8	1.0	mA
Shutdown Supply Current	I_{SHDN}	$V_{EN} = 0V$		0.1	1	μA
V_{IN} UVLO						
Under Voltage Lockout	V_{UVLO}	V_{IN} Rising	3.3	3.8	4.3	V
UVLO Hysteresis	V_{HYS}			200		mV
Feedback Voltage						
Feedback Voltage	V_{FB}	$-40^\circ C \leq T_A \leq 85^\circ C$	0.785	0.810	0.835	V
Feedback Over Voltage Threshold	V_{FBOV}			0.972		
FB Input Bias Current	I_{FB}	$V_{FB} = 0.85V$	-100		100	nA
Output						
Switch R_{DSON}	R_{DSON}	$I_{SW} = 1.0A$		0.35		Ω
Switch Leakage Current	I_{LEAK}	$V_{IN} = 18V$, $V_{EN} = 0V$		0.1	10	μA

ELECTRICAL CHARACTERISTICS
 $V_{IN} = V_{EN} = 12V$, $V_{OUT} = 3.3V$, $T_A = 25^\circ C$, unless otherwise specified.

Parameters	Symbol	Test Conditions/Comments	MIN	TYP	MAX	Units
Switch Current Limit	I_{LIM}		1.8	2.4	3.36	A
Thermal Shutdown	T_{OTSD}			160		$^\circ C$
Thermal Shutdown Hysteresis	T_{HYS}			20		$^\circ C$
Oscillator						
Oscillator Frequency	f_{OSC1}	$V_{FADJ} = GND$	1.1	1.4	1.7	MHz
Maximum Duty Cycle	D_{MAX}	$V_{FB} = 0.6V$		90		%
Minimum Duty Cycle	D_{MIN}	$V_{FB} = 0.9V$			0	%
Minimum On Time*	T_{ON}			100	130	ns
Short Circuit						
Hiccup time*	T_{HICCUP}			270	375	μS
Soft Start						
Soft Start Time	T_{SS}			300		μs
EN Input						
EN Pin Threshold	V_{EN_H}		1.5			V
	V_{EN_L}				0.4	

*Guaranteed by design, not production tested

FUNCTIONAL PIN DESCRIPTION

Pin Number	Pin Name	Function
1	BS	Bootstrap pin. A bootstrap capacitor is connected between the BS pin and SW pin. The voltage across the bootstrap capacitor drives the internal high-side NMOS switch.
2	GND	Ground pin.
3	FB	Feedback pin. This pin is connected to an external resistor divider to program the converter output voltage. When the FB pin voltage exceeds 120% of the nominal regulation value of 0.81V, the over voltage protection is triggered. When the FB pin voltage is below 0.25V and over current is triggered, the oscillator frequency is lowered to provide short circuit protection.
4	EN	Control input pin. Setting this pin above 1.5V enables the IC. Setting this pin below 0.4V shuts down the IC. When the IC is in shutdown mode, all functions are disabled to decrease the supply current below 1 μA .
5	IN	Supply input pin. A capacitor should be connected between the IN pin and GND pin to keep the DC input voltage constant.
6	SW	Power switch output pin. This pin is connected to the inductor and bootstrap capacitor.

FUNCTIONAL BLOCK DIAGRAM

Figure 1. LX7104 Functional Block Diagram.



PRODUCTION DATASHEET

STARTUP BY EN PIN

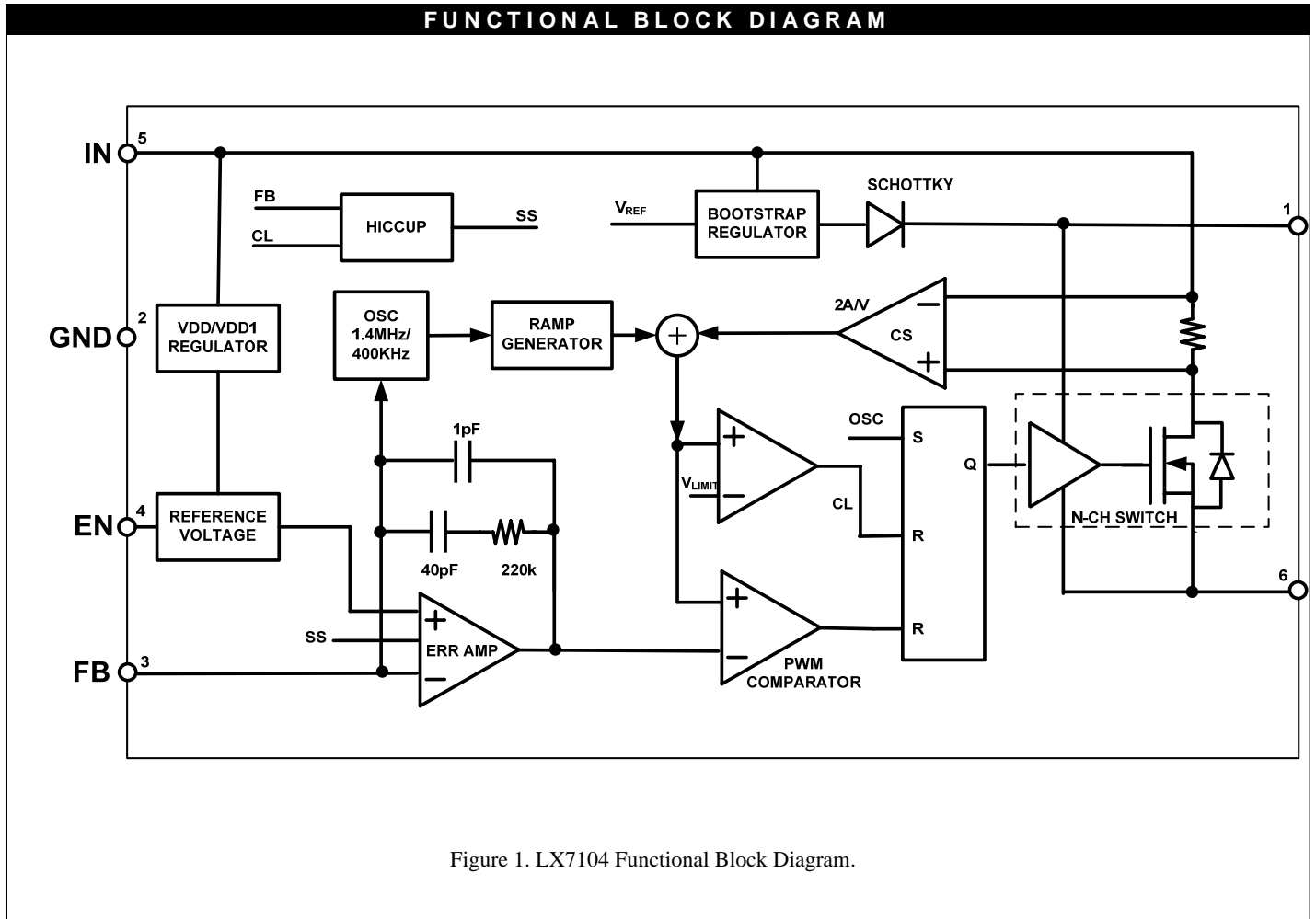
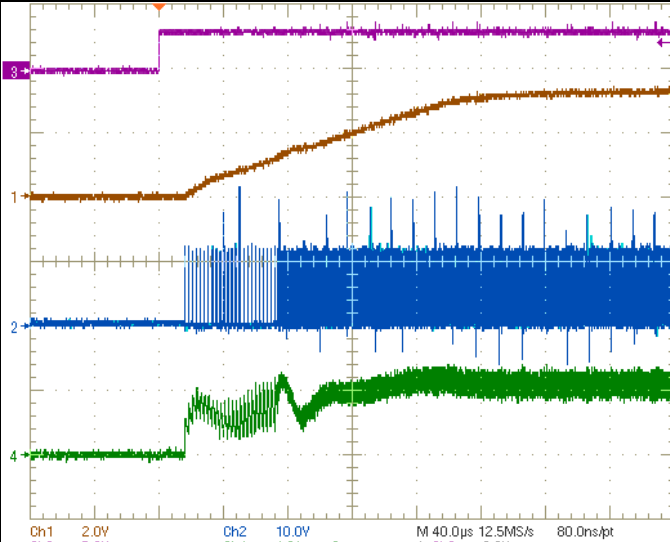

CH3 EN, CH1 VOUT, CH2 SW
CH4 Inductor Current

SHUTDOWN BY EN PIN

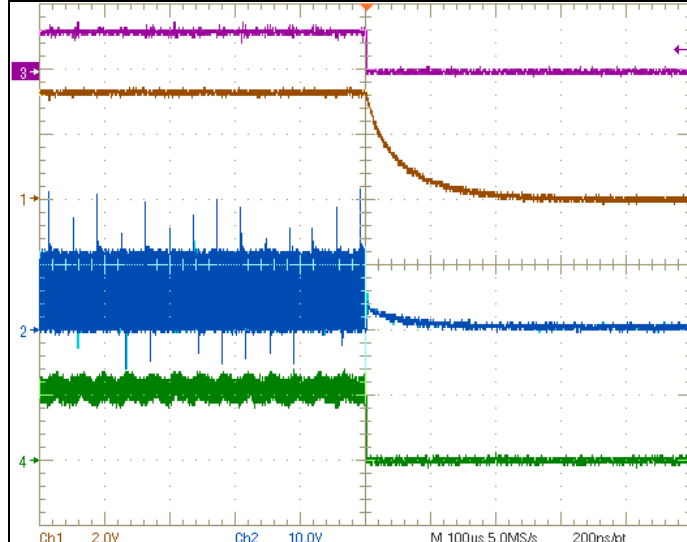

CH3 EN, CH1 VOUT, CH2 SW
CH4 Inductor Current

OUTPUT RIPPLE @ 0.5A

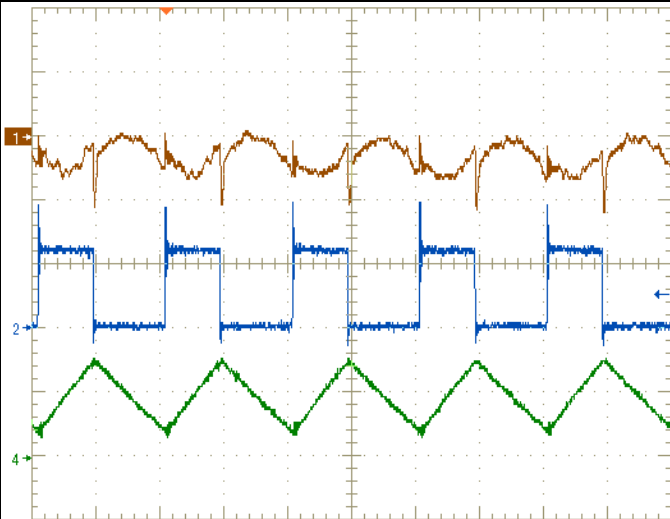

CH1 VOUT AC, CH2 SW
CH4 Inductor Current

OUTPUT TRANSIENT RESPONSE

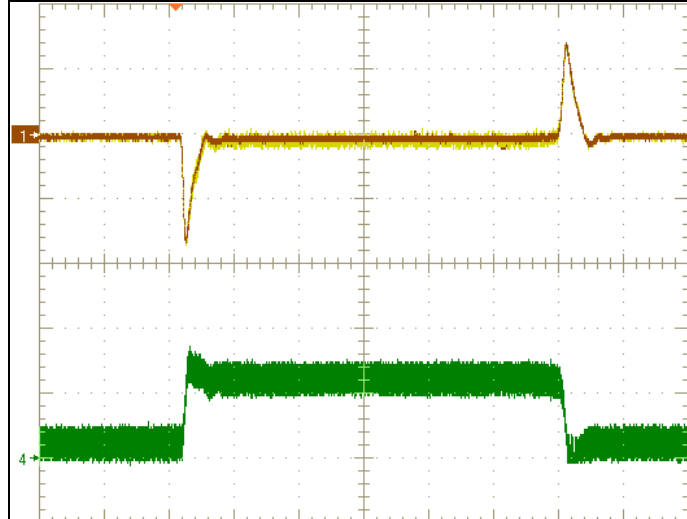

CH1 VOUT AC
CH4 Inductor Current



PRODUCTION DATASHEET

SHORT VOUT

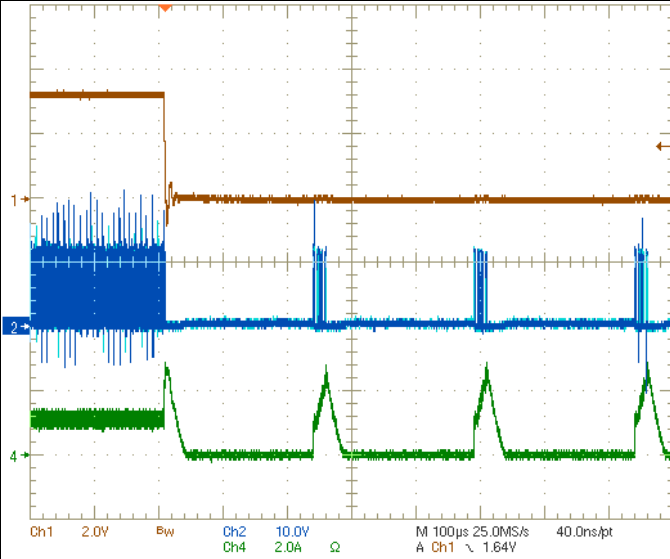

CH1 VOUT, CH2 SW, CH4 Inductor Current

OUTPUT SHORT RECOVERY

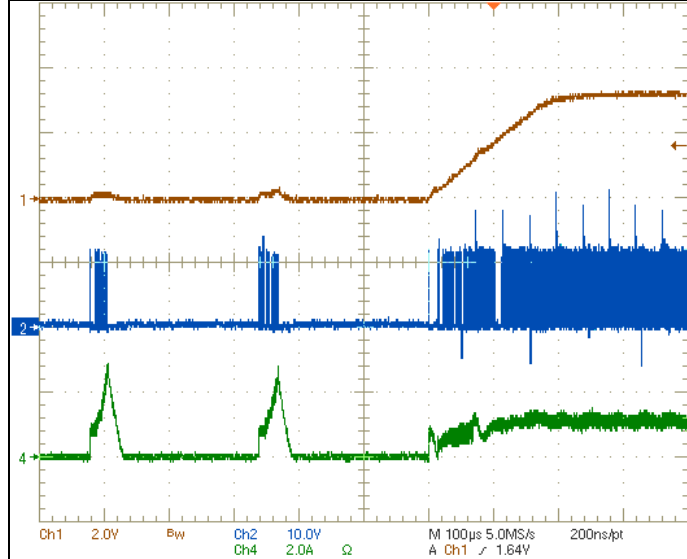

CH1 VOUT, CH2 SW, CH4 Inductor Current

EFFICIENCY VS VOUT & IOUT (VIN=12V)

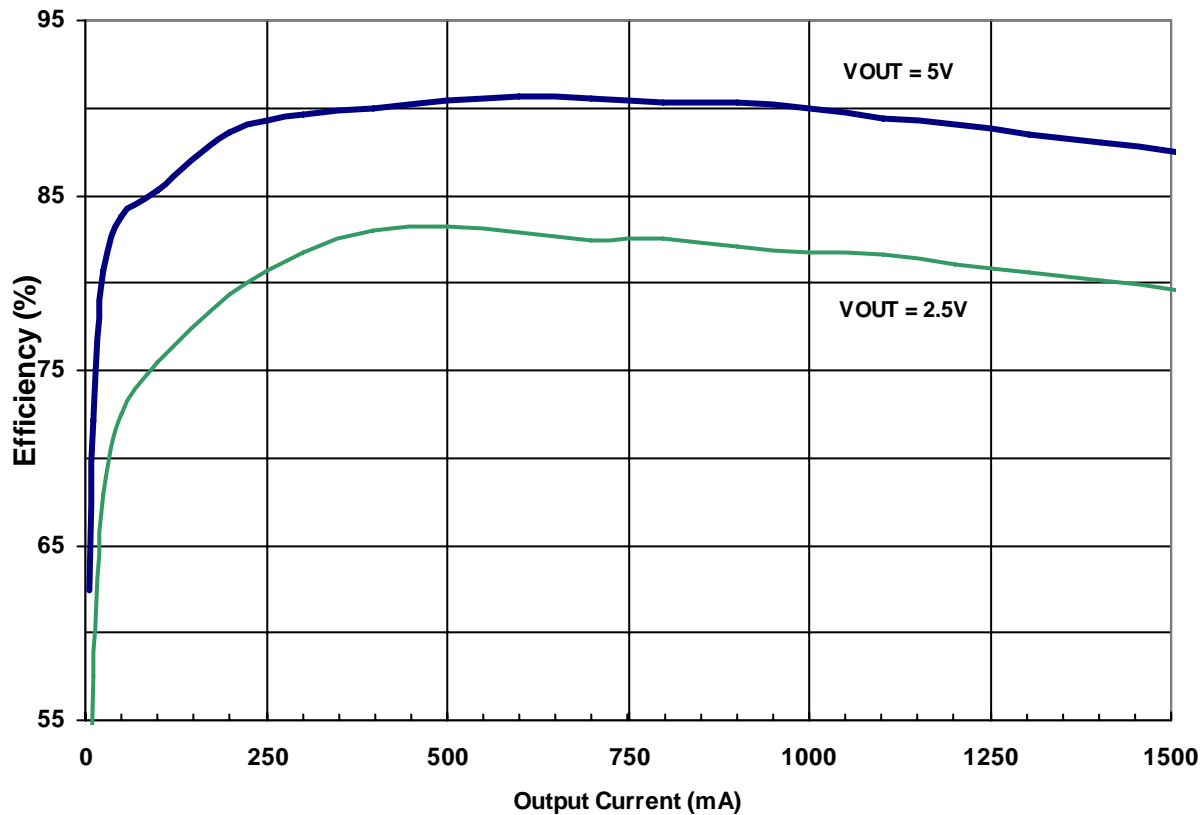

APPLICATION INFORMATION
OUTPUT VOLTAGE CALCULATION

Output voltage is set by reference voltage and external voltage divider. The reference voltage is nominally fixed at 0.81V. The divider consists of the ratio of two resistors selected so that the output voltage applied at the FB pin is 0.81V when the output voltage is at the desired level. The following equation and illustration indicate the relationship between output voltage and resistive voltage divider.

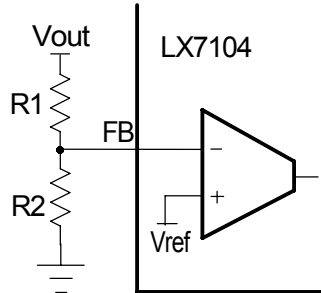

Figure 2 Voltage Divider

$$V_{OUT} = V_{REF} \times \left(1 + \frac{R_1}{R_2}\right) \dots \dots \dots (1)$$

The value of upper feedback resistor R1 needs to be set properly in order to have stable system. The recommended values of R1 and R2 are shown in the table below.

Table 1. Recommended value of feedback resistor divider for typical application shown in page 1.

Desired Output Voltage	R1	R2
2.5V	49.9kΩ	23.7kΩ
3.3V	49.9 kΩ	16.2 kΩ
5V	49.9 kΩ	9.53 kΩ

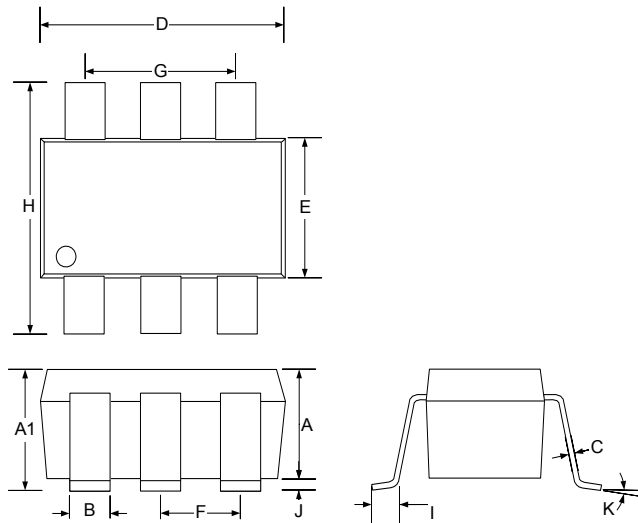
PACKAGE DIMENSIONS
SF 6-Pin SOT-23 Package

Dim	MILLIMETERS		INCHES	
	MIN	MAX	MIN	MAX
A	0.90	1.30	0.035	0.051
A1	-	1.45	-	0.057
B	0.25	0.50	0.010	0.020
C	0.09	0.20	0.004	0.008
D	2.80	3.10	0.110	0.122
E	1.50	1.75	0.059	0.069
F	0.95 BSC		0.037 BSC	
G	1.90 BSC		0.075 BSC	
H	2.60	3.00	0.102	0.118
I	0.30	0.60	0.012	0.024
J	0.00	0.15	0.000	0.006
K	10° MAX		10° MAX	

Note:

- Dimensions do not include mold flash or protrusions; these shall not exceed 0.155mm(.006") on any side. Lead dimension shall not include solder coverage.

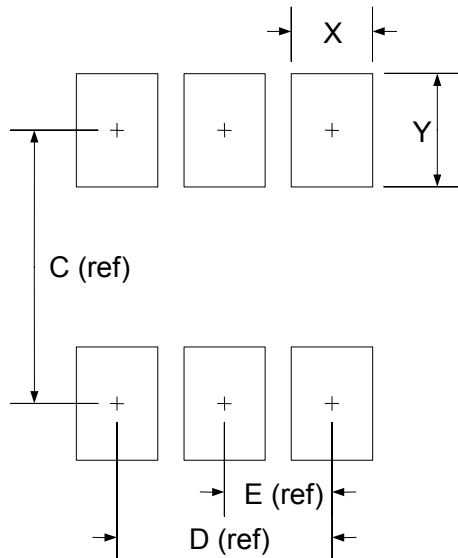
Recommended Footprint

Dim	MILLIMETERS		INCHES	
	MIN	MAX	MIN	MAX
C	-	2.40	-	0.094
D	-	1.90	-	0.074
E	-	0.95	-	0.037
X	-	0.70	-	0.028
Y	-	1.00	-	0.039



NOTES

PRODUCTION DATA – Information contained in this document is proprietary to Microsemi and is current as of publication date. This document may not be modified in any way without the express written consent of Microsemi. Product processing does not necessarily include testing of all parameters. Microsemi reserves the right to change the configuration and performance of the product and to discontinue product at any time.