

LX1701 / LX1701SPK AUDIOMAX EVALUATION KIT USER'S GUIDE



LX1701 Evaluation Board Quick Start Guide

The LX1701 Evaluation Board is a fully functional filterless mono class-D amplifier. Connection to a single power supply, even two AA batteries, one speaker, and an audio source like portable player or computer is all that is required to begin evaluating the amplifier. The amplifier will support continuous output power levels up to 2W into 4 Ω load (<10% THD+N).

Board Setting

1. Power and Ground Connections: The terminal J3 is for the power supply connection. VBAT is connected to the positive polarity of the power supply or battery (+1.8V ~ +5V); the GND is connected to the negative polarity of the power supply or battery. Please make sure your power supply polarity connection and supply voltage is correct before you start to evaluate the board.
2. Speakers Connection: J4 is the speaker output. Connect speaker "+" and "-" to "OUT+/OUT-". This evaluation board is designed for > 4 Ω speaker loads.
3. Audio Input Connection: J1 is the audio input connection. The positive audio inputs are connected to IN+ pin, while the negative inputs are connected to IN- pin. For single-ended audio input, the audio signal is connected to IN+ and ground connected to IN-.
4. "Enable/Disable" Jumper Setting: JP2 is the jumper for "Enable/Disable". Enable jumper must be closed for normal system operation.
5. "BW_SEL" (Bandwidth Selection) Jumper Setting: JP3 is for low frequency cut off corner frequency selection. There are two choices: one is 20Hz if "20Hz" position is closed; another one is 300Hz if "300Hz" position is closed.
6. "Gain" Jumper Setting: JP1 is the jumper for system gain selection. There are also two choices: 14dB if "14dB" position is closed; 8dB if "8dB" position is closed.
7. Output Selection Jumper Setting: JP4 & JP5 is the jumpers for LC filter or filterless output selection. Default setting is filterless output, which "filterless+" and "filterless-" positions are closed. L1/L2, C6/C7 are optional components for LC filter output when "LC+" and "LC-" positions are closed. L1/L2 could be inductors, or Ferrite Beads for long speaker wires output to speaker.
8. Test Set Up: R1/R2/R3/R4/R5 & C2/C3/C4/C5 are components for test purpose (refer to next page schematic), they are not necessary for the real application circuit. They make a second order RC filter cutting off the high switching frequency, to measure the audio signal more precisely. R1 is an on-board load, can be 4~16 Ω , 2W resistor, you also can connect a resistor load off the board through the output terminal without on-board load. The probes just touch "TESTOUT+" and "TESTOUT-" test points, you can measure audio performance of the board

Actually this evaluation board is added a lot of optional components, or for test purpose, also some headers, terminals for input and output, they are not necessary for the real application. The real component for this system is only one: C1, for the power supply ripple. Another application board we made only has this one component on the board except for the IC, you can find the schematic and picture in the page? It is sold separately.

TEST PROCEDURES

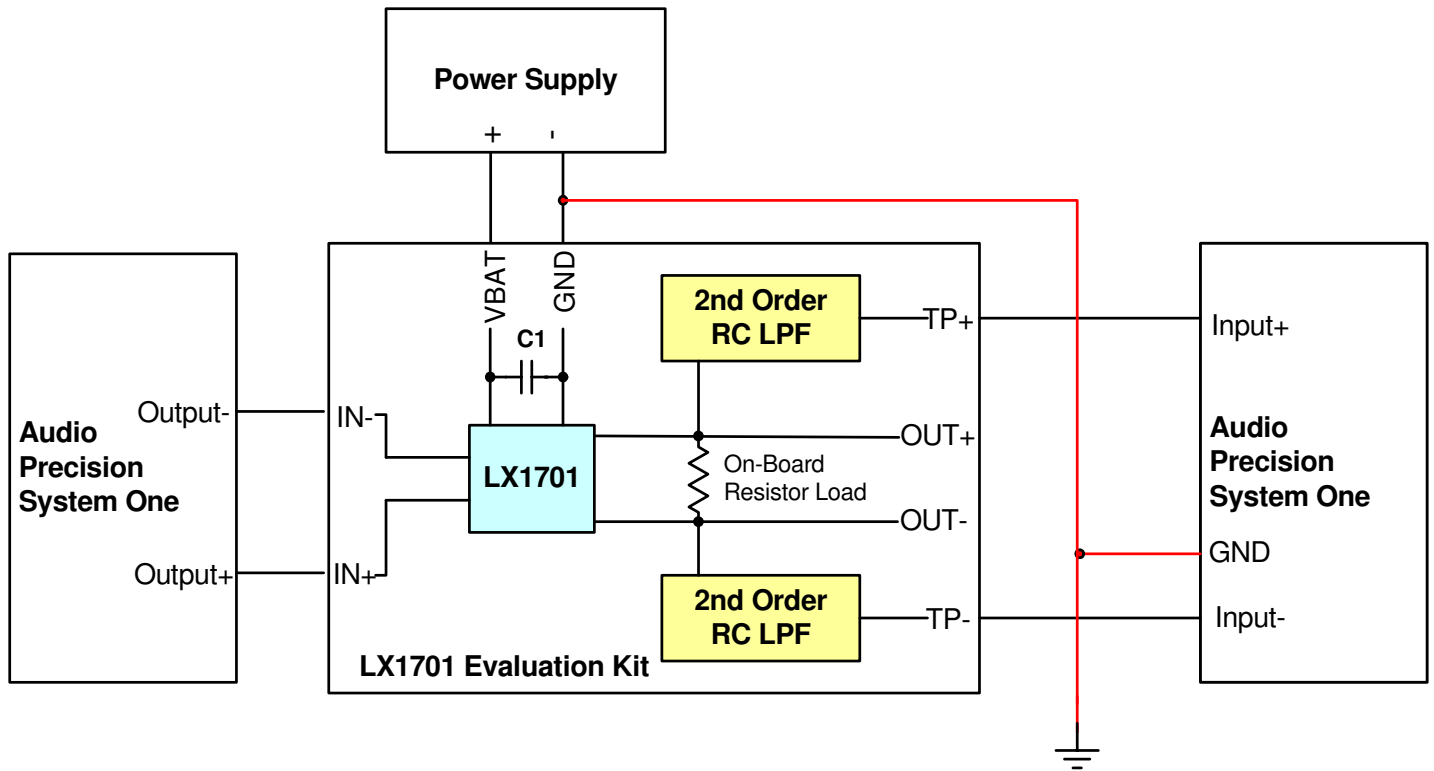

FIGURE 3 - LX1701 TEST SYSTEM SETUP

➤ **Default Settings:**

Equipments: Audio Precision SYSTEM 1,

Oscilloscope,

Power Supply ~+5V;

Supply Voltage: 1.8V/3.3V/5.0V 3 corner voltages

On-Board passive LPF: 40KHz cut off frequency (-3dB)

On-Board resistor load: 4/8 Ω, 2W

AP settings: 10Hz ~ 22KHz BPF

TEST PROCEDURES(CONT.)**➤ THD+N vs. Output Power**

Tested signal frequency $f=1\text{KHz}$, through On-Board PC LPF to minimize the switching noise, keep measuring accuracy

➤ THD+N vs. Frequency

Tested signal level $P_o=100\text{mW}$, sweep input signal frequency from 20Hz to 20KHz, through On-Board PC LPF to minimize the switching noise, keep measuring accuracy

➤ Frequency response

Tested signal level $P_o=100\text{mW}$, sweep input signal frequency from 20Hz to 20KHz, not through On-Board PC LPF, directly test it from OUT+ and OUT-

Change JP3, the BandWidth selection jumper to change the HPF cutoff frequency, then measure it

➤ Signal-to-Noise Ratio (SNR)

Input short, output through TP1 and TP2 into AP input, AP is set up with FFT digital analyzer function, A-weighted filter, 0dB as maximum output power with 1%THD+N

➤ Efficiency

Output power vs. power supply power, since resistor is acting as a load even at high switching frequency, the On-Board load resistor is removed and the output through OUT+/OUT- into a speaker load because the speaker can act as an inductor to cut off the higher switching frequency to keep measuring accuracy. Tested signal is $f=1\text{KHz}$ sine wave.

➤ GAIN

Same procedure with frequency response, set 0dB as input signal level

Change JP1, the gain selection jumper to change its gain, and measure it

APPLICATIONS

LX1701SPK* is evaluation/application module; it has very compact size (22mm x 13mm). On the board, there are only two components, one is LX1701, and another is a surface mount CAP 4.7uF. It is easy for users to directly embed this module into speaker, connect to the audio source and 2 or 3 "AA" size batteries, and then plug-play.

* - It is sold separately.

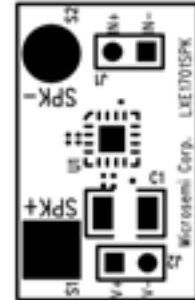
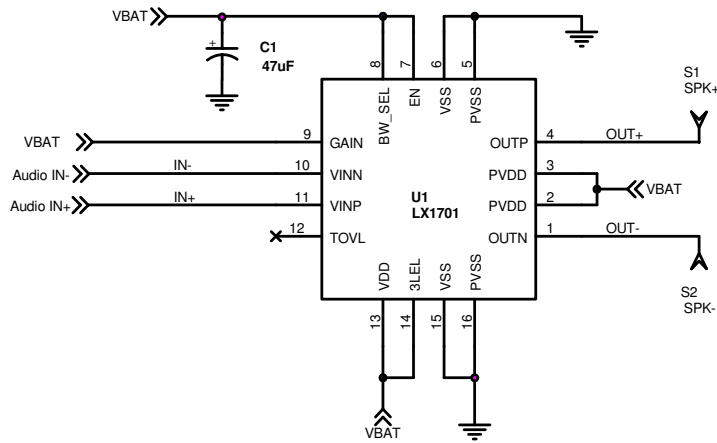

FIGURE 4 - LX1701SPK EVALUATION/APPLICATION MODULE



Example of LX1701's size:

BILL OF MATERIAL

MISCELLANEOUS COMPONENTS

Line Item	Part Description	Manufacturer & Part #		Case	Reference Designators	Qty
1	IC, Class-D Audio Controller	<i>Microsemi</i>	LX1701CLQ	SM	U1	1
2	PC Test Points, .125", White	Keystone	5007-White	TH	TP1, TP2	2
3	Connector Headers, .100" Center, 2POS	Amp	87220-2	TH	J1, J2	2
4	Connector Headers, .100" Center, 3POS	Amp	87220-3	TH	JP1, JP2, JP3, JP4, JP5	5
5	Shorting Jumpers, Opren Top, Black	Sullen	STC02SYAN	TH	JP1, JP2, JP3 JP4, JP5	5
6	Terminal Block, 2POS 5mm	Block Master	301-021-1000	TH	J3, J4	2
7	PCB, Microsemi, LXE1701-X2	<i>Microsemi</i>	LXE1701	PCB	Reev> X2	1

CAPACITORS

Line Item	Part Description	Part Description	Case	Reference Designators	Qty
1	Capacitor, X7R, .47μF, 16V, 20%	AVX 1206YC474MAT2A	1206	C1	1
2	Capacitor, COG, 2.2nF, 16V, 5%	TDK C2012COG1C222J	0805	C3, C5	2
3	Capacitor, COG, 4.7nF, 16V, 5%	TDK C2012COG1C472J	0805	C2, C4	2

RESISTORS

Line Item	Part Description	Part Description	Case	Reference Designators	Qty
1	Resistor, 470 Ohm, 5% 1/8W	ASJ CR21J471T	0805	R2, R3, R4, R5	4