



1.8V/3.0V Single-PLL Clock Generator AK8150C

Features

- **Input Frequency:**
38 MHz (1.8V or 3.0V)
- **PLL Output Frequency:**
12 MHz (1.8V or 3.0V)
- **REF Output Frequency:**
38 MHz or 19 MHz (1.8V or 3.0V)
- **Low Jitter Performance:**
Cycle to Cycle : 200 ps max
Period : 120 ps max
- **Low Current Consumption:**
12 mW max
- **Output Load:**
30 pF Max
- **Supply Voltage:**
VDD : 1.8V±0.1V
VDDO1,2 : 1.8V±0.1V or 3.0V±0.3V
- **Operating Temperature Range:**
-20 to +85°C
- **Package:**
8-pin USON (2.0mm x 2.0mm)

Description

The AK8150C is a single-PLL clock generator IC with two outputs. The high performance PLL locks to the master clock input, generating a low jitter, highly accurate clock output without an external crystal.

The integrated PLL generates 12MHz with 38 MHz input clock. The device has another output, REF which is to be ICLK or ICLK divided by two.

The AK8150C has two kinds of voltage supply pins. One is for the core and the other is for each of the two output buffers. The core requires 1.8V supply and the output buffers require 1.7V - 1.9V or 2.7V - 3.3V supply. Not only the output but also the input accepts 1.8V or 3.0V input clock from Crystal Oscillator.

Applications

- Digital Still Camera
- Digital Video Camera

Block Diagram

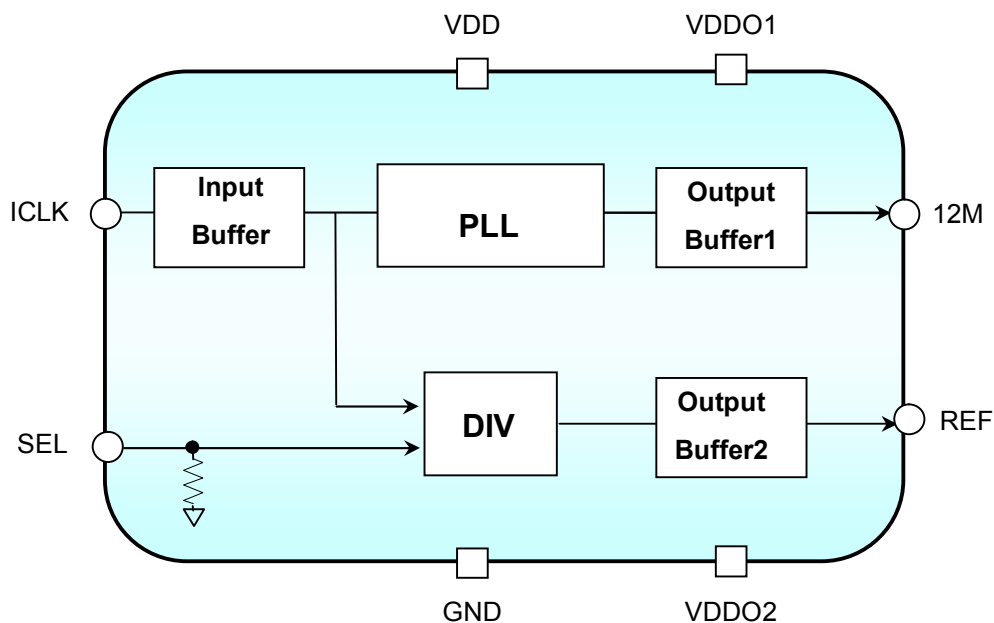

AK8150C Single PLL with Two Outputs Clock Generator

PIN DESCRIPTION

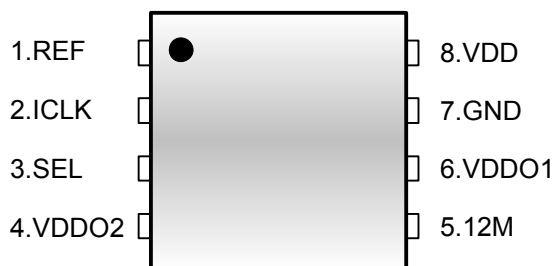

Package: 8-Pin USON (Top View)

Pin No.	Pin Name	Pin Type	Description	
1	REF	OUT	Reference output of ICLK or ICLK/2. One of which is selected by SEL pin.	
2	ICLK	IN	38 MHz input. 1.8V or 3.0V available.	
3	SEL	IN	Select pin for REF Output Frequency. 1.8V or 3.0V available. “L” : ICLK “H” : ICLK/2	(1)
4	VDDO2	--	Power supply of Output Buffer for REF	
5	12M	OUT	12MHz output.	
6	VDDO1	--	Power supply of Output Buffer for 12M	
7	GND	--	Ground	
8	VDD	--	Power supply	

(1) Internal pull down 200k Ω (Typ.)

Ordering Information

Part Number	Marking	Shipping Packaging	Package	Temperature Range
AK8150CU	150C	Tape and Reel	8-pin USON	-20 to 85°C

Absolute Maximum Rating

Over operating free-air temperature range unless otherwise noted ⁽¹⁾

Items	Symbol	Ratings	Unit
Supply Voltage	VDD	-0.3 to 4.6	V
Input Voltage	V _{in}	VSS-0.3 to 3.6	V
Input Current (any pins except supplies)	I _{IN}	±10	mA
Storage Temperature	T _{stg}	-55 to 130	°C

Note

(1) Stress beyond those listed under “Absolute Maximum Ratings” may cause permanent damage to the device. These are stress ratings only. Functional operation of the device at these or any other conditions beyond those indicated under “Recommended Operating Conditions” is not implied. Exposure to absolute-maximum-rating conditions for extended periods may affect device reliability. Electrical parameters are guaranteed only over the recommended operating temperature range.



ESD Sensitive Device

This device is manufactured on a CMOS process, therefore, generically susceptible to damage by excessive static voltage. Failure to observe proper handling and installation procedures can cause damage. AKM recommends that this device is handled with appropriate precautions.

Recommended Operation Conditions

Parameter	Symbol	Conditions	Min	Typ	Max	Unit
Operating Temperature	T _a		-20		85	°C
Supply Voltage 1	VDD		1.7	1.8	1.9	V
Supply Voltage 2	VDDO1	1.8V output	1.7	1.8	1.9	V
	VDDO2	3.0V output	2.7	3.0	3.3	
Input Clock Frequency	F _{in}			38.0		MHz
Input Clock Duty Cycle				50		%
Output Load Capacitance	C _p	Pin: 12M, REF			30	pF

DC Characteristics

All specifications at VDD: 1.7 to 1.9V, VDDO1,2: 2.7 to 3.3V, Ta: -20 to +85°C, unless otherwise noted

Parameter	Symbol	Conditions	Min	Typ	Max	Unit
High level input voltage	V _{IH}	Pin: ICLK, SEL	0.8*VDDI		VDDI	V
Low level input voltage	V _{IL}	VDDI: 1.7-1.9V or 2.7-3.3V	VSS		0.2*VDDI	V
Input leakage current 1	I _{L1}	Pin: ICLK	-10		+10	μA
Input leakage current 2	I _{L2}	Pin: SEL	-10		+40	μA
High level output voltage	V _{OH}	12M IOH= -5mA	0.8*VDDO1			V
		REF IOH= -5mA	0.8*VDDO2			
Low level output voltage	V _{OL}	12M IOH= +5mA			0.2*VDDO1	V
		REF IOH= +5mA			0.2*VDDO2	
Power Consumption	W	No load VDD=1.8V, VDDO1,2 = 3.0V			12	mW

VDDI: Power Supply for Input clock generator such as Crystal Oscillator.

AC Characteristics

All specifications at VDD: 1.7 to 1.9V, VDDO1,2: 2.7 to 3.3V, Ta: -20 to +85°C, unless otherwise noted

Parameter	Symbol	Conditions	MIN	TYP	MAX	Unit
Output Clock Frequency 1	fo1	Pin: 12M		12		MHz
Output Clock Frequency 2	fo2	Pin: REF SEL=L		38		MHz
		Pin: REF SEL=H		19		MHz
Output Clock Duty Cycle 1 ⁽²⁾⁽³⁾		Pin: 12M Cp=30pF	45	50	55	%
Output Clock Duty Cycle 2 ⁽²⁾⁽³⁾		Pin: REF SEL=L, Cp=30pF Input clock duty = 50%	40	50	60	%
		Pin: REF SEL=H, Cp=30pF	45	50	55	%
Output Clock Rise Time ⁽²⁾⁽³⁾	t _{rise}	Pin: 12M, REF 0.2VDD to 0.8VDD, Cp=30pF			4.0	ns
Output Clock Fall Time ⁽²⁾⁽³⁾	t _{fall}	Pin: 12M, REF 0.2VDD to 0.8VDD, Cp=30pF			4.0	ns
Period Jitter ⁽²⁾⁽³⁾	Jit	Pin: 12M, REF 1000 cycle, Cp=30pF			120	ps
Cycle to Cycle Jitter ⁽²⁾⁽³⁾	Jit	Pin: 12M, REF 1000 cycle, Cp=30pF			200	ps
Output Lock Time ⁽¹⁾	t _{lock}	Power-up			3	ms

(1) The time that output reaches the target frequency within accuracy of ±0.1% from the point that the power supply reaches VDD

(2) With the load capacitance specified by the recommended operation conditions

(3) Design value

Package Information

- Mechanical data (Units:mm)

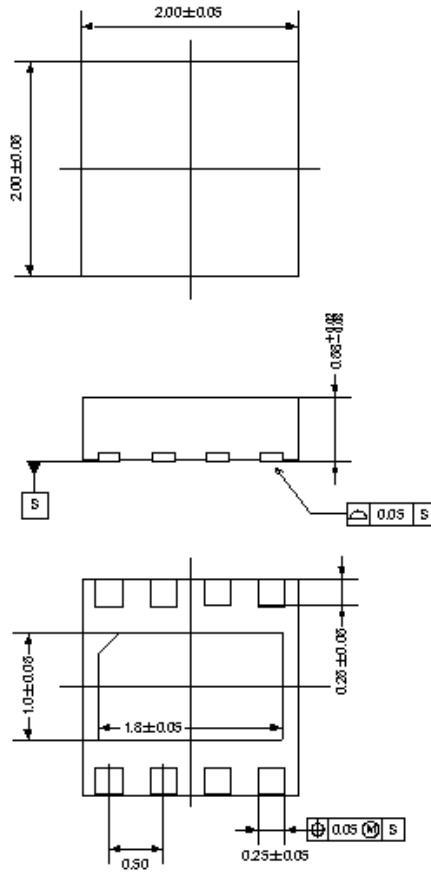

- Marking

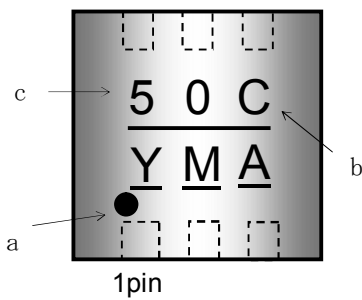

- a: #1 Pin Index
- b: Part number
- c: Date code (3 digits)

AKM and the logo - - are the brand of AKM's IC's and identify that AKM continues to offer the best choice for high performance mixed-signal solution under this brand.

RoHS Compliance

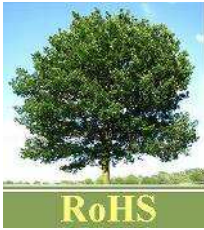

All integrated circuits from Asahi Kasei Microdevices (AKM) assembled in “lead-free” packages* are fully compliant with RoHS.

(*) RoHS compliant products from AKM are identified with “Pb free” letter indication on product label posted on the anti-shield bag and boxes.

IMPORTANT NOTICE

- These products and their specifications are subject to change without notice. When you consider any use or application of these products, please make inquiries the sales office of Asahi Kasei Microdevices Corporation (AKM) or authorized distributors as to current status of the products.
- Descriptions of external circuits, application circuits, software and other related information contained in this document are provided only to illustrate the operation and application examples of the semiconductor products. You are fully responsible for the incorporation of these external circuits, application circuits, software and other related information in the design of your equipments. AKM assumes no responsibility for any losses incurred by you or third parties arising from the use of these information herein. AKM assumes no liability for infringement of any patent, intellectual property, or other rights in the application or use of such information contained herein.
- Any export of these products, or devices or systems containing them, may require an export license or other official approval under the law and regulations of the country of export pertaining to customs and tariffs, currency exchange, or strategic materials.
- AKM products are neither intended nor authorized for use as critical components^{Note1)} in any safety, life support, or other hazard related device or system^{Note2)}, and AKM assumes no responsibility for such use, except for the use approved with the express written consent by Representative Director of AKM. As used here:
 - Note1) A critical component is one whose failure to function or perform may reasonably be expected to result, whether directly or indirectly, in the loss of the safety or effectiveness of the device or system containing it, and which must therefore meet very high standards of performance and reliability.
 - Note2) A hazard related device or system is one designed or intended for life support or maintenance of safety or for applications in medicine, aerospace, nuclear energy, or other fields, in which its failure to function or perform may reasonably be expected to result in loss of life or in significant injury or damage to person or property.
- It is the responsibility of the buyer or distributor of AKM products, who distributes, disposes of, or otherwise places the product with a third party, to notify such third party in advance of the above content and conditions, and the buyer or distributor agrees to assume any and all responsibility and liability for and hold AKM harmless from any and all claims arising from the use of said product in the absence of such notification.