



Low Power Multiclock Generator AK8146A

Features

- 24.0MHz External Input or Crystal Input
- Clock out Frequencies:
 - 24.000MHz
 - 20.48MHz
 - 4.000MHz
- Low Jitter Performance
 - Period Jitter:
25 psec (Typ.) at CLK1-2
- Low Current Consumption:
5.0mA (Typ.) at 3.3V
- Supply Voltage:
3.0 – 3.6V
- Operating Temperature Range:
-20 to +85°C
- Package:
8-pin MSOP (Lead free)

Description

The AK8146A is a low power multi clock generator which generates different frequency clocks from a 24MHz crystal oscillator or external clock input. It provides up to three outputs. The PLL in the AK8146A is derived from AKM's high-performance clock device technology, enabling the clock output to perform with low jitter and to operate with very low current consumption. The AK8146A is available in an 8-pin MSOP package.

Applications

- Digital TV Sets
- Personal Video Recorders
- Set-Top-Boxes
- Multi Media Receivers

Block Diagram

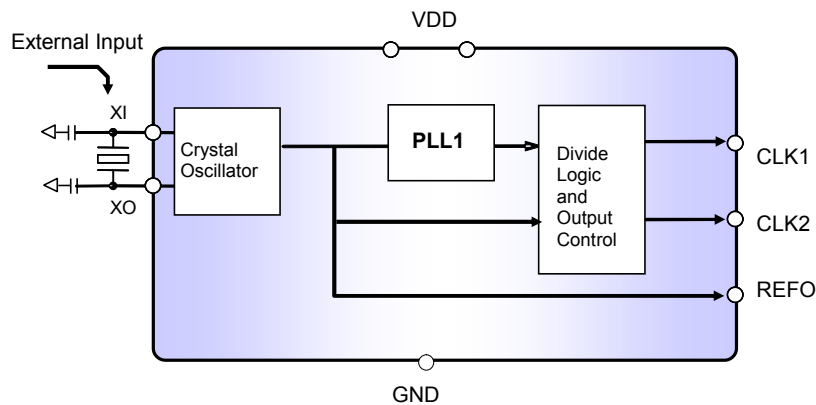

AK8146A Multi Clock Generator

Pin Descriptions

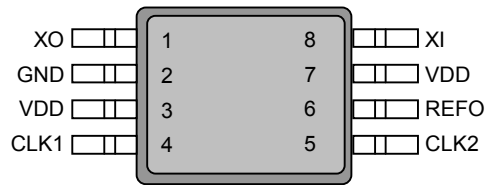

Package: 8-Pin MSOP(Top View)

Pin No.	Pin Name	Pin Type	Description
1	XO	XO	Crystal connection, Connect to 24.000MHz crystal Leave this pin floating when the external clock is used.
2	GND	PWR	Ground
3	VDD	PWR	3.3V
4	CLK1	OUT	20.48MHz
5	CLK2	OUT	4.0MHz
6	REFO	OUT	24.000MHz
7	VDD	PWR	3.3V
8	XI	XI	Crystal Input or Reference Clock Input 24.000MHz

Ordering Information

Part Number	Marking	Shipping Packaging	Package	Temperature Range
AK8146A	146A	Tape and Reel	8-pin MSOP	-20 to 85 °C

Absolute Maximum Rating

Over operating free-air temperature range unless otherwise noted ⁽¹⁾

Items	Symbol	Ratings	Unit
Supply voltage	VDD	-0.3 to 4.6	V
Input voltage	V _{in}	VSS-0.3 to VDD+ 0.3	V
Input current (any pins except supplies)	I _{IN}	± 10	mA
Storage temperature	T _{stg}	-55 to 130	°C

Note

(1) Stress beyond those listed under “Absolute Maximum Ratings” may cause permanent damage to the device. These are stress ratings only. Functional operation of the device at these or any other conditions beyond those indicated under “Recommended Operating Conditions” is not implied. Exposure to absolute-maximum-rating conditions for extended periods may affect device reliability. Electrical parameters are guaranteed only over the recommended operating temperature range.



ESD Sensitive Device

This device is manufactured on a CMOS process, therefore, generically susceptible to damage by excessive static voltage. Failure to observe proper handling and installation procedures can cause damage. AKEMD recommends that this device is handled with appropriate precautions.

Recommended Operation Conditions

Parameter	Symbol	Conditions	Min	Typ	Max	Unit
Operating temperature	T _a		-20		85	°C
Supply voltage ⁽¹⁾	VDD		3.0	3.3	3.6	V
Output Load Capacitance	C _{p1}	Pin: CLK1,2,REFO			15	pF

Note:

(1) Power to VDD requires to be supplied from a single source. A decoupling capacitor of 0.1μF for power supply line should be installed close to each VDD pin.

DC Characteristics

All specifications at VDD: over 3.0 to 3.6V, Ta: -20 to +85°C, 24MHz Crystal, unless otherwise noted

Parameter	Symbol	Conditions	MIN	TYP	MAX	Unit
High Level Output Voltage	V_{OH}	Pin: CLK1-2, REFO $I_{OH} = -4mA$	0.8VDD			V
Low level Output Voltage	V_{OL}	Pin: CLK1-2, REFO $I_{OL} = +4mA$			0.2VDD	V
Current Consumption	I_{DD}	No load Ta=25°C		5.0		mA

AC Characteristics

All specifications at VDD: over 3.0 to 3.6V, Ta: over -20 to +85°C, 24MHz Crystal, unless otherwise noted

Parameter	Symbol	Conditions	MIN	TYP	MAX	Unit
Crystal Clock Frequency ⁽¹⁾				24.0		MHz
External Clock Input		Pin: XI 500mVp-p or more Duty:30%-70% @0.5*(Input Swing)		24.0		MHz
Period Jitter ⁽³⁾		CLK1-2		25		ps
Output Clock Duty Cycle		Pin: CLK1-2	45	50	55	%
		Pin: REFO	40	50	60	%
Output Clock Rise Time	t_{rise}	Pin: CLK1-2, REFO ⁽²⁾		1.5	4.0	ns
Output Clock Fall Time	t_{fall}	Pin: CLK1-2, REFO ⁽²⁾		1.5	4.0	ns
Power-up Time ⁽⁴⁾		Pin: CLK1-2 ⁽²⁾		1		ms

(1) AT cut, Fundamental mode

Recommended Crystal Unit : HC-49/U03C (RIVER ELETEC CORP.)

(2) Measured with load capacitance of 15pF

(3) 1σ in 10000 sampling or more

(4) The time that output reaches the target frequency within accuracy of $\pm 0.1\%$ from the point that the power supply reaches VDD

Package Information

• Mechanical data

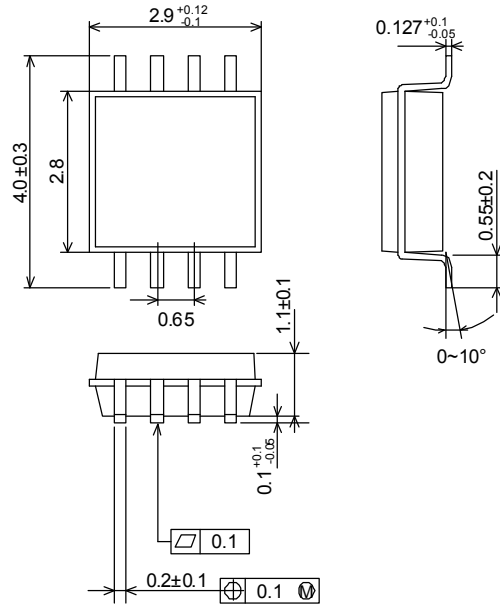

• Marking

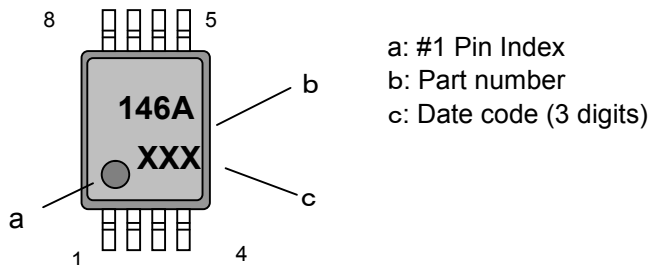

AKM and the logo -  - are the brand of AKM's IC's and identify that AKM continues to offer the best choice for high performance mixed-signal solution under this brand.

• RoHS Compliance

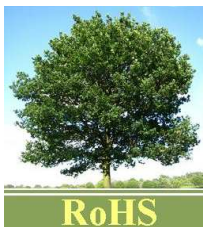

All integrated circuits from Asahi Kasei Microdevices (AKM) assembled in "lead-free" packages* are fully compliant with RoHS.

(*) RoHS compliant products from AKM are identified with "Pb free" letter indication on product label posted on the anti-shield bag and boxes.

IMPORTANT NOTICE

- | These products and their specifications are subject to change without notice.
When you consider any use or application of these products, please make inquiries the sales office of Asahi Kasei Microdevices Corporation (AKM) or authorized distributors as to current status of the products.
- | AKM assumes no liability for infringement of any patent, intellectual property, or other rights in the application or use of any information contained herein.
- | Any export of these products, or devices or systems containing them, may require an export license or other official approval under the law and regulations of the country of export pertaining to customs and tariffs, currency exchange, or strategic materials.
- | AKM products are neither intended nor authorized for use as critical components^{Note1)} in any safety, life support, or other hazard related device or system^{Note2)}, and AKM assumes no responsibility for such use, except for the use approved with the express written consent by Representative Director of AKM. As used here:
 - Note1) A critical component is one whose failure to function or perform may reasonably be expected to result, whether directly or indirectly, in the loss of the safety or effectiveness of the device or system containing it, and which must therefore meet very high standards of performance and reliability.
 - Note2) A hazard related device or system is one designed or intended for life support or maintenance of safety or for applications in medicine, aerospace, nuclear energy, or other fields, in which its failure to function or perform may reasonably be expected to result in loss of life or in significant injury or damage to person or property.
- | It is the responsibility of the buyer or distributor of AKM products, who distributes, disposes of, or otherwise places the product with a third party, to notify such third party in advance of the above content and conditions, and the buyer or distributor agrees to assume any and all responsibility and liability for and hold AKM harmless from any and all claims arising from the use of said product in the absence of such notification.