



# Single Clock Generator AK8128B

## Features

- **Output Frequency Range:**  
74.25MHz, (74.25/1.001)MHz  
148.5MHz, (148.5/1.001)MHz
- **Input Frequency:**  
27MHz, 48.0MHz
- **Low Jitter Performance:**  
20 ps (Typ.) Period,  $1\sigma$   
300ps(Typ.) 1000cycle long term, p-p
- **Low Current Consumption:**  
8mA (Typ.)  
10mA(Typ.)
- **Output Load:**  
15pF (max.) for 74.25MHz, (74.25/1.001)MHz  
10pF (max.) for 148.5MHz, (148.5/1.001)MHz
- **Supply Voltage:**  
2.85 – 3.6V
- **Operating Temperature Range:**  
-20 to +85°C
- **Package:**  
10-pin TMSOP (lead-free)

## Description

The AK8128B is a single clock generator IC with an integrated PLL. It can generate HDMI clock from a 27MHz or 48MHz master clock input frequency. A high performance PLL locks to the master clock input, generating a low jitter, highly accurate clock output without an external crystal.

## Applications

- DTV
- PVR
- DVC
- DSC

## Block Diagram

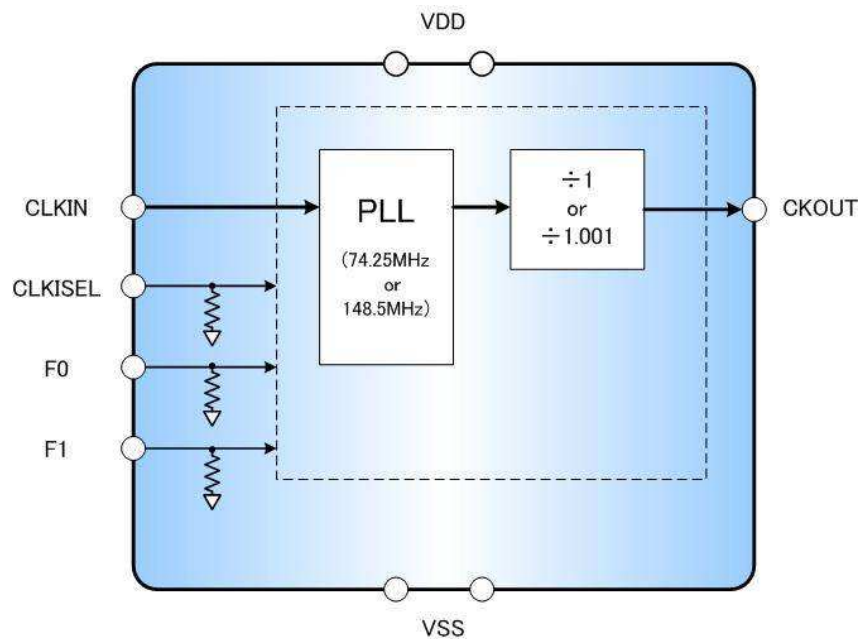

AK8128B Single Clock Generator

**Pin Descriptions Package: 10-Pin TMSOP (Top View)**

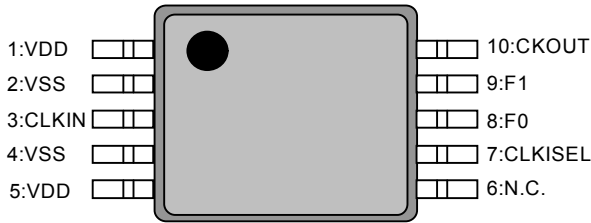

Pin No.	Pin Name	Pin Type	Description
1	VDD	--	Power Supply
2	VSS	--	Ground
3	CLKIN	IN	27MHz / 48MHz External Clock Input Input Clock Frequency is selectable by CLKISEL pin.
4	VSS	--	Ground
5	VDD	--	Power Supply
6	N.C	--	Connect to VSS
7	CLKISEL	IN	Input Clock Frequency Select Pin L:27.0MHz, H:48.MHz (1)
8	F0	IN	Clock Frequency Range Select Pin 0. (1) (2)
9	F1	IN	Clock Frequency Range Select Pin 1. (1) (2)
10	CKOUT	OUT	Clock Output

- (1) Internal pull down 400kΩ (Typ.)
- (2) See Table1 for output frequency settings.

**Table 1: Operation Clock Frequency Setting**

Pin Setting		CKOUT1 (MHz)
F1	F0	
L	L	74.25
L	H	74.25/1.001
H	L	148.5
H	H	148.5/1.001

**Ordering Information**

Part Number	Marking	Shipping Packaging	Package	Temperature Range
AK8128B	128B	Tape and Reel	10-pin TMSOP	-20 to 85 °C

## Absolute Maximum Rating

Over operating free-air temperature range unless otherwise noted <sup>(1)</sup>

Items	Symbol	Ratings	Unit
Supply Voltage	VDD	-0.3 to 4.6	V
Input Voltage	V <sub>in</sub>	VSS-0.3 to VDD+0.3	V
Input Current (any pins except supplies)	I <sub>IN</sub>	±10	mA
Storage Temperature	T <sub>stg</sub>	-55 to 130	°C

Note

(1) Stress beyond those listed under “Absolute Maximum Ratings” may cause permanent damage to the device. These are stress ratings only. Functional operation of the device at these or any other conditions beyond those indicated under “Recommended Operating Conditions” is not implied. Exposure to absolute-maximum-rating conditions for extended periods may affect device reliability. Electrical parameters are guaranteed only over the recommended operating temperature range.



### ESD Sensitive Device

This device is manufactured on a CMOS process, therefore, generically susceptible to damage by excessive static voltage. Failure to observe proper handling and installation procedures can cause damage. AKM recommends that this device is handled with appropriate precautions.

## Recommended Operation Conditions

Parameter	Symbol	Conditions	Min	Typ	Max	Unit
Operating Temperature	T <sub>a</sub>		-20		85	°C
Supply Voltage <sup>(1)</sup>	VDD		2.85	3.3	3.6	V
Input Clock Frequency	F <sub>in</sub>			27.0 48.0		MHz
Input Clock Duty Cycle		At VDD/2	30		70	%
Output Load Capacitance	C <sub>p1</sub>	74.25MHz, 74.175MHz			15	pF
	C <sub>p2</sub>	148.5MHz, 148.351MHz			10	pF

Note:

(1) Power to VDDs requires to be supplied from a single source. A decoupling capacitor of 0.1μF for power supply line should be installed close to each VDD pin.

## DC Characteristics

All specifications at VDD: over 2.85 to 3.6V, Ta: -20 to +85°C, Input Frequency: 27MHz, unless otherwise noted

Parameter	Symbol	Conditions	MIN	TYP	MAX	Unit
High Level Input Voltage	V <sub>IH</sub>	Pin: CLKIN, CLKISEL, FSEL, OE	0.7VDD			V
Low Level Input Voltage	V <sub>IL</sub>	Pin: CLKIN, CLKISEL, FSEL, OE			0.3VDD	V
Input Current 1	I <sub>L1</sub>	Pin: CLKIN	-10		+10	μA
Input Current 2	I <sub>L2</sub>	Pin: CLKISEL, F0, F1	-20		+20	μA
High Level Output Voltage	V <sub>OH</sub>	Pin: CLKOUT I <sub>OH</sub> =-4mA	0.8VDD			V
Low Level Output Voltage	V <sub>OL</sub>	Pin: CLKOUT I <sub>OL</sub> =+4mA			0.2VDD	V
Current Consumption1	I <sub>DD1</sub>	No load @74.25MHz (VDD=3.3V, Ta=25°C)		8	12	mA
Current Consumption2	I <sub>DD2</sub>	No load @148.5MHz (VDD=3.3V, Ta=25°C)		10	15	

## AC Characteristics

All specifications at VDD: over 2.85 to 3.6V, Ta: -20 to +85°C, Input Frequency: 27MHz, unless otherwise noted

Parameter	Symbol	Conditions	MIN	TYP	MAX	Unit
Output Clock Duty Cycle		At VDD/2	45	50	55	%
Output Clock Rise Time <sup>(1)(2)</sup>	t <sub>rise</sub>	0.2VDD to 0.8VDD		1.2	2.0	ns
Output Clock Fall Time <sup>(1)(2)</sup>	t <sub>fall</sub>	0.2VDD to 0.8VDD		1.2	2.0	ns
Output Clock Jitter 1 <sup>(1)</sup>	Jit1	Period, 1σ in 10000 sampling		20	100	ps
Output Clock Jitter 2 <sup>(1)</sup>	Jit2	Long term 1000 cycle p-p ±3σ in 10000 sampling		300	450	ps
Output Lock Time <sup>(1)(3)</sup>	t <sub>lock</sub>	Power-up		1	3	ms

(1) Design Value

(2) With the load capacitance specified by the recommended operation conditions

(3) The time that output reaches the target frequency within accuracy of ±0.1% from the point that the power supply reaches VDD

## Package Information

### • Mechanical data

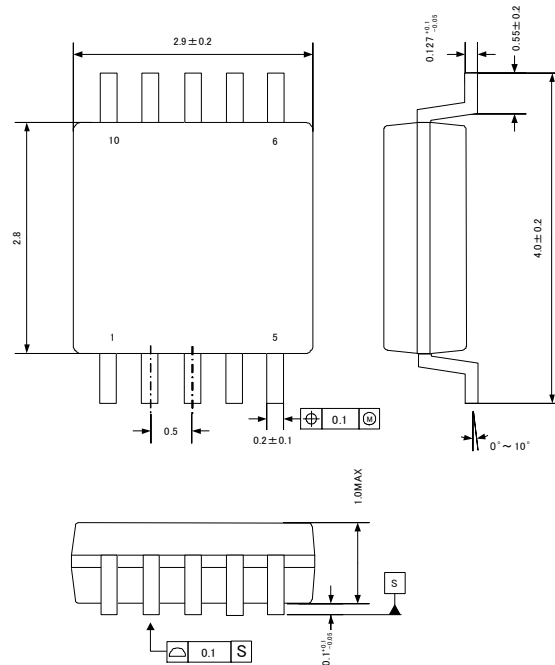

### • Marking

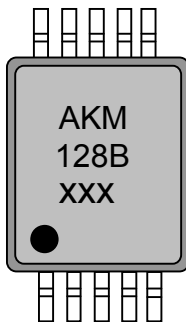

- a: #1 Pin Index
- b: Part number
- c: Date code (3 digits)
- d: Product Family Logo

### • RoHS Compliance

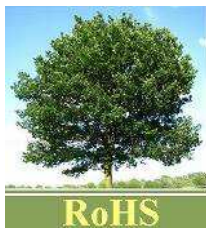

All integrated circuits from Asahi Kasei Microdevices Corporation (AKM) assembled in “lead-free” packages\* are fully compliant with RoHS.

(\*) RoHS compliant products from AKM are identified with “Pb free” letter indication on product label posted on the anti-shield bag and boxes.

## IMPORTANT NOTICE

- These products and their specifications are subject to change without notice. When you consider any use or application of these products, please make inquiries the sales office of Asahi Kasei Microdevices Corporation (AKM) or authorized distributors as to current status of the products.
- Descriptions of external circuits, application circuits, software and other related information contained in this document are provided only to illustrate the operation and application examples of the semiconductor products. You are fully responsible for the incorporation of these external circuits, application circuits, software and other related information in the design of your equipments. AKM assumes no responsibility for any losses incurred by you or third parties arising from the use of these information herein. AKM assumes no liability for infringement of any patent, intellectual property, or other rights in the application or use of such information contained herein.
- Any export of these products, or devices or systems containing them, may require an export license or other official approval under the law and regulations of the country of export pertaining to customs and tariffs, currency exchange, or strategic materials.
- AKM products are neither intended nor authorized for use as critical components<sup>Note1)</sup> in any safety, life support, or other hazard related device or system<sup>Note2)</sup>, and AKM assumes no responsibility for such use, except for the use approved with the express written consent by Representative Director of AKM. As used here:
  - Note1) A critical component is one whose failure to function or perform may reasonably be expected to result, whether directly or indirectly, in the loss of the safety or effectiveness of the device or system containing it, and which must therefore meet very high standards of performance and reliability.
  - Note2) A hazard related device or system is one designed or intended for life support or maintenance of safety or for applications in medicine, aerospace, nuclear energy, or other fields, in which its failure to function or perform may reasonably be expected to result in loss of life or in significant injury or damage to person or property.
- It is the responsibility of the buyer or distributor of AKM products, who distributes, disposes of, or otherwise places the product with a third party, to notify such third party in advance of the above content and conditions, and the buyer or distributor agrees to assume any and all responsibility and liability for and hold AKM harmless from any and all claims arising from the use of said product in the absence of such notification.